

SA4550 4-ATI PRIMARY ATTITUDE DISPLAY



The Sandel SA4550 Primary Attitude Display is the perfect update for aging electromechanical ADIs, and an ideal complement to the high-definition Sandel SN4500 Primary Navigation Display.

Featuring Sandel's patented LED display technology, generating a resolution of 200 pixels per inch, the SA4550 provides 180° horizontal and vertical viewing angles. You'll find the SA4550 completely transforms your panel. Reliable, affordable and backed by Sandel's award-winning product support, the SA4550 is ideal for corporate and air transport aircraft.

See what's next

SANDEL.

SA4550 4-ATI PRIMARY ATTITUDE DISPLAY

Drawing from our experience with thousands of compact integrated displays in service, we designed the SA4550 to do what no others can: Replace your electromechanical ADI with a modular electronic unit.

This allows you to update your panel with minimum disruption to your aircraft. And by saving on both acquisition and installation costs, the SA4550 is a cost-effective way to enhance both the operational and the residual value of your aircraft or fleet.

Weight	SA4550	3.4 lb. (1.54 kg)
Bracket & Connectors		0.5 lb (0.23 kg)
Dimensions		
Length		7.82 in. (19.86 cm) from back of bezel (Sperry AD-550 retrofit version) 7.51 in. (19.08 cm) from back of bezel (Sperry AD-600 and AD-650 retrofit versions)
Body		3.975 in. x 3.975 in. (10.084 cm x 10.084 cm)
Bezel		4.060 in. x 4.060 in. (10.312 cm x 10.312 cm)
Display		LED Backlit
NVIS Mode		Class B compatible per MIL-STD-3009
Power Requirements		20-33 VDC 28 VDC @ 1.4A (40W) nominal
Cooling Requirements		Internal fan requiring ambient air at fan input
Mounting		Standard 4-ATI panel cutout with clamp and Sperry compatible connectors Bezel adapters available for mounting in 4x5 and 5x5 panel cutouts

Operating Environment	-20 C. to +70 C. +55,000 ft. max. altitude
Certification Basis	TSO-C113, Airborne Multipurpose Electronic Displays TSO-C3d, Turn and Slip Instruments TSO-C4c, Bank and Pitch Instruments TSO-C34e, ILS Glide Slope Receiving Equipment TSO-C36e, Airborne ILS Localizer Receiving Equipment TSO-C52b, Flight Director Equipment EASA ETSO, 2C34F, 2C36F, C113, C3d, C4c, C52b DO-160E, Env. Cat. [A2F1Z]BBB[HR]XXXXXXXXZZAZ[ZW][WW]M[A3G33]XXAX DO-178B, Software, Attitude Level A, Guidance and Annunciators Level C DO-254, Hardware, Attitude Level A, Guidance and Annunciators Level C

Interfaces	
Attitude	Remote XYZ synchro (ARINC 407) for pitch and roll, ARINC 429*
Attitude Comparator	Analog
Flight Director	Analog
Glidescope/LOC	Analog
Fast/Slow	Analog
Radar Altimeter	ARINC 552, Sperry and Collins
Annunciators	Discrete

*Contact Sandel for ARINC 429 attitude input availability

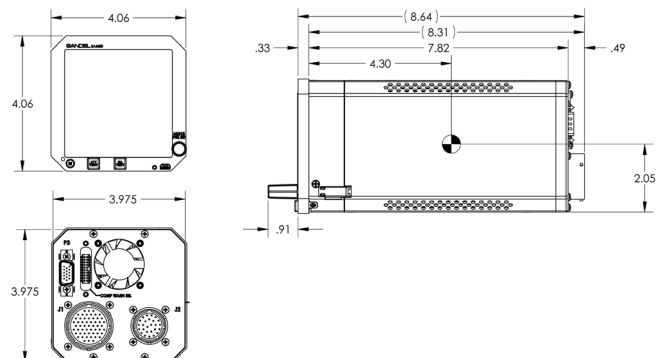
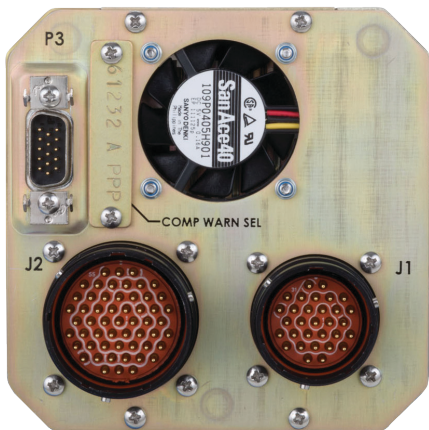

Dimensions and specifications subject to change without notice.



U.S. Department
of Transportation

**Federal Aviation
Administration**

May 8, 2007

Sandel Avionics Inc.
Mr. Gerald Block
2401 Dogwood Way
Vista, California 92081

Sandel Avionics, Inc.
Technical Standard Orders (TSO)-C3d, C4c, C34e, C36e, C52b, and -C113
for Sandel Avionics SA4550 Primary Attitude Display

Dear Mr. Block:

This is in reply to your letter dated May 7, 2007, requesting Technical Standard Order (TSO) authorization for your SA4550 Primary Attitude Display. The statement of conformance to TSO-C3d, C4c, C34e, C36e, C52b, and -C113, and the submitted data are accepted. Effective the date of this letter, you are authorized to identify the following SA4550 Primary Attitude Display with the marking requirements defined in Title 14 Code of Federal Regulations § 21.607 (d) and in TSO-C3d, C4c, C34e, C36e, C52b, and -C113.

<u>Part Number</u>	<u>Software Version</u>	<u>Description</u>
SA4550-(xxx)	Part No.: 82010-90, Version: 1.00	Primary Attitude Display

Your Quality Control System, as defined in your Quality Control Manual, currently on file at the Los Angeles Manufacturing Inspection District Office, is considered satisfactory for production of this article at your Vista, California facility.

As required by the TSO, the following statement must be furnished with each manufactured unit:

"The conditions and tests required for TSO approval of this article are minimum performance standards. It is the responsibility of those installing this article either on or within a specific type or class of aircraft to determine that the aircraft installation conditions are within the TSO standard. TSO articles must have separate approval for installation in an aircraft. The article may be installed only if performed under 14 CFR part 43 or the applicable airworthiness requirements."

Any design changes to this TSO article must be forwarded to this office as outlined in 14 CFR § 21.611(a) with minor changes submittal intervals not to exceed six months. Notification of changes should be made prior to shipment.

Received:
05/08/07 TUE 10:40 FAX 562 627 5210May 8 2007 11:35am
FAA LAACO ANM-100L #3

001

As recipient of this authorization, you are required to report any failure, malfunction, or defect relating to this authorization in accordance with the provisions of 14 CFR § 21.3. The report should be communicated initially by telephone to the Manager, Technical and Administrative Support Staff, ANM-103L, (562) 627-5300, within 24 hours after it has been determined the failure has occurred and followed up with a written notice. FAA Form 8010-4 (Malfunction or Defect Report) or other appropriate format is acceptable in transmitting the required details.

This authorization is not transferable to another person or location and is effective until surrendered, withdrawn, or otherwise terminated by the Administrator. This authorization pertains only to manufacturing operations at the above address. This office must be notified at least 30 days in advance of any proposed facility relocation to preclude interruption while awaiting quality control approval of that facility. As required by 14 CFR § 21.613(b), you must also notify the FAA when you no longer manufacture a TSO approved article.

Please note that technical data retained by the FAA may be subject to Freedom of Information Act (FOIA) request. As such, this office will notify you of all such requests pertaining to your data and afford you the opportunity to defend the release of the data.

If you have any questions regarding this authorization, contact Mr. Carlton Woo, Manager, Technical & Administrative Support Staff at (562) 627- 5300, or by e-mail carlton.woo@faa.gov or FAX number (562) 627-5210.

Sincerely,

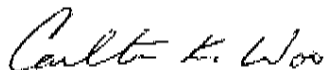

Carlton K. Woo
Manager, Technical and Administrative
Support Staff