

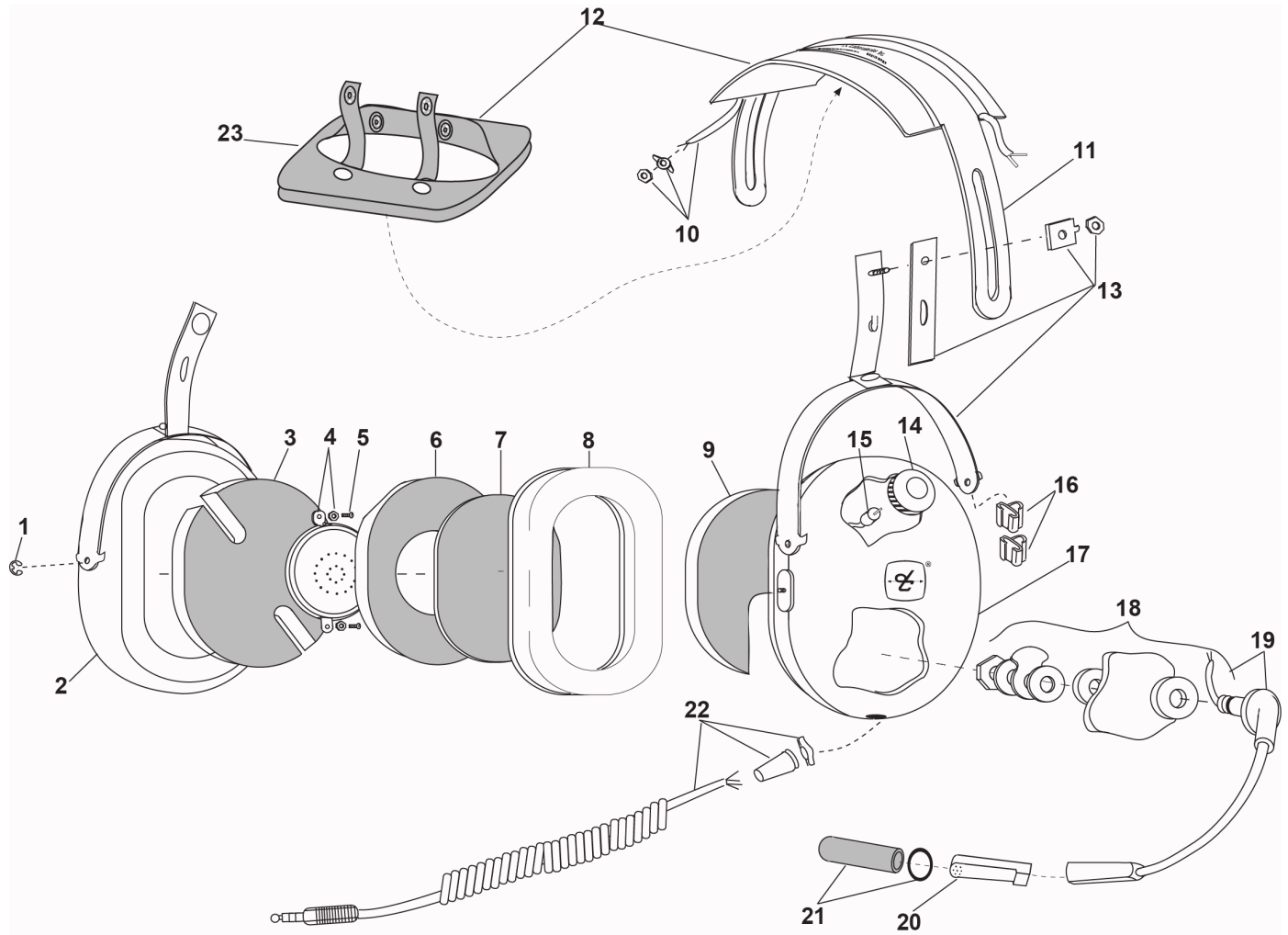

PARTS LIST
MODEL H10-26



No.	Description	Part No.
1	Retaining Ring (10/pk)	00009M-03
2	Right Dome	11696P-12
3	Dome Filter (1 each)	26475P-02
4	Earphone Assembly	10376G-20
5	Screw (10/pk)	13180P-06
6	Filter (1 each)	25629P-03
7	Filter (1 each)	14096P-09
8	Undercut Gel Earseal (pair)	40863G-02
9	Filter (1 each)	26475P-08
10	Overhead Cord Kit	22607G-01
11	Headband Spring	15093P-01
12	Headpad Assembly	18900G-45

No.	Description	Part No.
13	Stirrup & Clamp Kit	22378G-08
14	Volume Control Knob	15109P-01
15	Volume Control	09349P-34
16	Clip, Cord (4/pk)	15125P-02
17	Left Dome	11696P-40
18	Boom Attachment Kit	12840G-19
19	Kit, Boom Assembly w/Att.	41090G-12
20	M-7A Electret Mic	09168P-33
21	Mic Protector	40062G-02
22	Comm Cord Kit	18028G-05
23	Headpad Restraint, Foam	40266G-01

ELECTRICAL SCHEMATIC
MODEL H10-26

