

TCAS II CAS 67A

Pilot's Guide

Honeywell
Collision Avoidance System



The information contained in this manual is for reference use only. If any information contained herein conflicts with similar information contained in the Airplane Flight Manual Supplement, the information in the Airplane Flight Manual Supplement shall take precedence.

WARNING

The enclosed technical data is eligible for export under License Designation NLR and is to be used solely by the individual/organization to whom it is addressed. Diversion contrary to U.S. law is prohibited.

COPYRIGHT NOTICE

Copyright ©1999, 2004 Honeywell International Inc.
All rights reserved.

Reproduction of this publication or any portion thereof by any means without the express written permission of Honeywell International Inc. is prohibited. For further information contact the Manager, Technical Publications; Honeywell; One Technology Center; 23500 West 105th Street; Olathe, Kansas 66061. Telephone: (913) 712-0400.

SYSTEM COMPONENTS	2
INTRODUCTION	4
SECTION I : OPERATION	5
TCAS II Operation	7
TCAS II Traffic Display Symbols	8
Non-Threat Traffic	9
Proximity Intruder Traffic	9
Traffic Advisory (TA)	10
Resolution Advisory (RA)	11
Off Scale Traffic	12
No Bearing Traffic	12
The RA/VS1 Instrument	13
The TA/VS1 Instrument	14
How To Fly Typical TCAS II Commands	14
Audio Announcements	24
Audio Messages	24
Resolution Advisories and Synthesized Voice Announcements	25
RA Increases and Reversals	25
List of Resolution Advisories	26
SECTION II: CONTROLS AND DISPLAYS	29
Transponder/ TCAS Control Unit; CTA 81A, B, C, & D	31
KFS 578A Transponder/ TCAS Control Unit	36
PS 578A Transponder/TCAS Control Unit	39
CD 671C Transponder/ TCAS Control Unit	42
PS 550 Transponder/ TCAS Control Unit	46
Color Weather Radar Indicators	50
Radar Only Mode	51
Radar with TCAS Overlay Mode	52
TCAS Only Mode	53
Weather Modes Message Format	55
TCAS Mode Message Format	56
Fault Message Format	57
ITA 81A Dedicated TCAS Traffic Display	58
IVA 81B & KAV 485T RA/VS1 Resolution Advisory/ Vertical Speed Indicator	60
IVA 81A/C/D TA/VS1 Traffic Advisory/Vertical Speed Indicator	61
Typical TA/VS1 Scenarios	64
SECTION III: SYSTEM CONSIDERATIONS	67
Warnings and Limitations	68
Cautions	69
Notes	70
SECTION IV: APPENDIX	71
Functional and Automatic Self Test	73
Glossary of TCAS Terms	78

COCKPIT DISPLAYS



**IVA 81A/C/D
TA/RA VSI**



**IVA 81B
RA VSI**



**KAV 485T
ALT VSI/RA**



**ITA 81A DEDICATED TA
TRAFFIC DISPLAY**

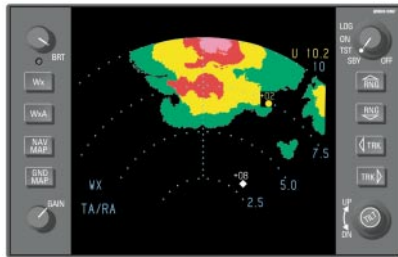

**TRAFFIC ON AN RDS PRIMUS,
OR COLLINS RADAR DISPLAY**

MODE S/TCAS CONTROL PANELS



CTA 81A



PS 550



CD 671C



KFS 578A



PS 578A



RMU 556

REMOTE-MOUNTED HARDWARE

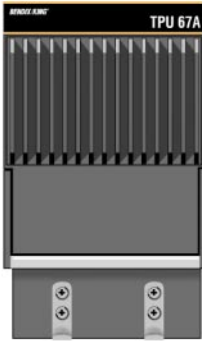

**TPU 67A TCAS
PROCESSOR**



**MST 67A
MODE S
TRANSPONDER**

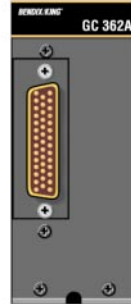

**GC 362A
GRAPHICS
PROCESSOR**



**DUAL L-BAND OMNI
DIRECTIONAL
ANTENNAS**



**ANT 67A DIRECTIONAL
ANTENNA**

INTRODUCTION

TCAS II is a system used for detecting and tracking aircraft in the vicinity of your own aircraft. By interrogating their transponders it analyzes the replies to determine range, bearing, and if reporting altitude, the relative altitude of the intruder. Should the TCAS II processor determine that a possible collision hazard exists, it issues visual and audio advisories to the crew for appropriate vertical avoidance maneuvers.

TCAS is unable to detect any intruding aircraft without an operating ATCRBS transponder (operating in Mode A and C) or a Mode S transponder.

There are two types of cockpit displays for TCAS II, the Resolution Advisory (RA) display and the Traffic Advisory (TA) display. The RA display is incorporated into the vertical speed indicator (VSI). By illuminating red and green arcs around the dial it displays the required rate, or limitation of climb or descent, to avoid a possible collision.

The TA display shows the intruding aircraft's relative position and altitude with a trend arrow to indicate if it is climbing or descending at greater than 500 feet per minute. This TA display may be provided on the weather radar indicator, on a dedicated TCAS display or a TA/VSI display.

The TA display identifies the relative threat of each intruder by using various symbols and colors. Complementing the displays, TCAS II provides appropriate synthesized voice announcements. A complete list of symbols and announcements is given in the Operation section of this Operator's Manual.

ATC procedures and the "see and avoid concept" will continue to be the primary means of ensuring aircraft separation. However, if communication is lost with ATC, TCAS II adds a significant backup for collision avoidance.

SECTION I : OPERATION

SECTION I DESCRIBES BASIC OPERATION OF THE TCAS II SYSTEM.

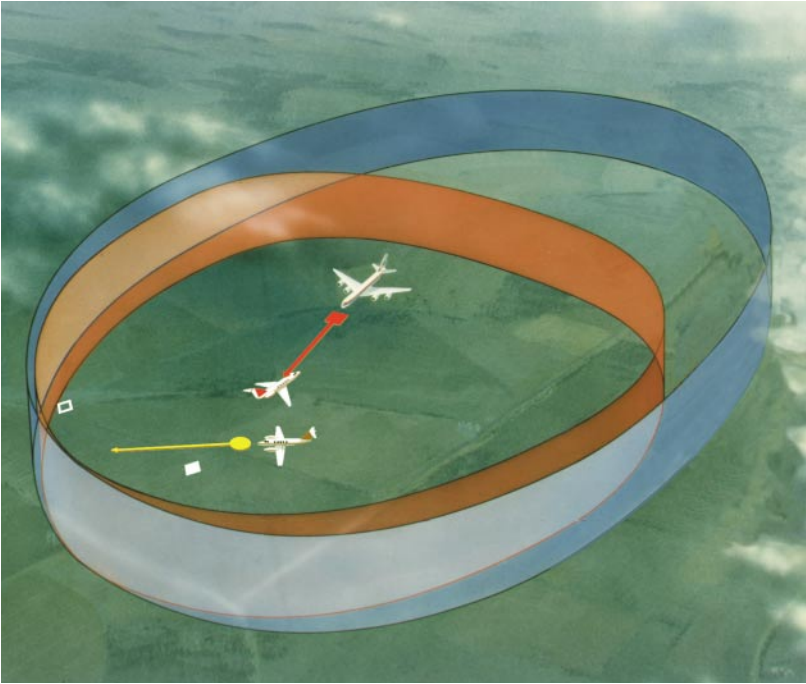

TCAS II:

- Compatible with and independent of the ATC System
- Determines if a threat exists
- Calculates appropriate vertical evasive maneuver
- Provides display and audio announcement to the crew
 - Position information displayed on CRT and/or TA/VI
 - Vertical Guidance displayed on VSI
 - Synthesized voice
- Coordinates maneuvers of two or more TCAS II equipped aircraft via Mode S transponder communication

TCAS II OPERATION

The TCAS II system monitors the airspace surrounding your aircraft by interrogating the transponder of intruding aircraft. The interrogation reply enables TCAS II to compute the following information about the intruder:

1. Range between your aircraft and the intruder.
2. Relative bearing to the intruder.
3. Altitude and vertical speed of the intruder, if reporting altitude.
4. Closing rate between the intruder and your aircraft.

Using this data TCAS II predicts the time to, and the separation at, the intruder's closest point of approach (CPA). Should TCAS II predict that certain safe boundaries may be violated, it will issue a Traffic Advisory (TA) to alert the crew that closing traffic is in the vicinity.

If the intruder continues to close, TCAS II will issue a Resolution Advisory (RA) to maintain safe vertical separation between your aircraft and the intruder. TCAS II bases the alarms on a five second crew reaction time to achieve adequate separation. Increase or reversal of an RA requires a reaction in two and one half seconds.

Two TCAS II equipped aircraft will coordinate their resolution advisories using a Mode S transponder data link. The coordination ensures that complementary advisories are issued in each aircraft. The crew should promptly but smoothly follow the advisory. Since the maneuvers are coordinated, the crew should never maneuver in the opposite direction of the advisory.

TCAS II can track as many as 45 aircraft, display up to 30 of them and can coordinate a resolution advisory for up to three intruders at once. The advisories are always based on the least amount of deviation from the flight path while providing safe vertical separation.

TCAS II TRAFFIC DISPLAY SYMBOLS

TCAS II will display four different traffic symbols on the Traffic Advisory displays. The type of symbol selected by TCAS II is based on the intruder's location and closing rate.

The symbols change shape and color to represent increasing levels of urgency.

The traffic symbols may also have an associated altitude tag which shows relative altitude (FL) in hundreds of feet, indicating whether the intruder is climbing, flying level or descending. A + sign and number above the symbol means the intruder is above your altitude. A - sign and number beneath indicates it is below your altitude. A trend arrow appears when the intruder's vertical rate is 500 feet per minute or greater.

No altitude number or trend arrow will appear beside the intruder that is non-altitude reporting (NAR). If TCAS II direction finding techniques fail to locate the azimuth of another aircraft, a NO BEARING message appears on the screen.

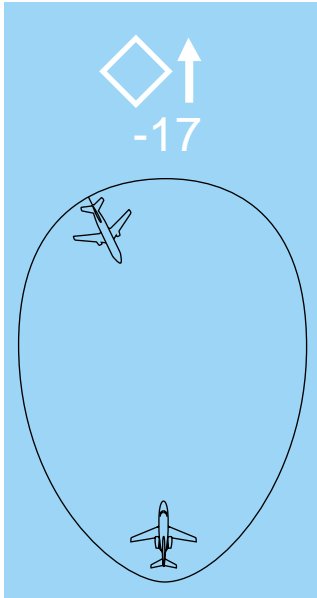
NON-THREAT TRAFFIC

An open white diamond indicates that an intruder's relative altitude is greater than ± 1200 feet, or its distance is beyond 6 nm range. It is not yet considered a threat.

This one is 1700 feet below your own altitude, climbing at 500 feet per minute or greater.

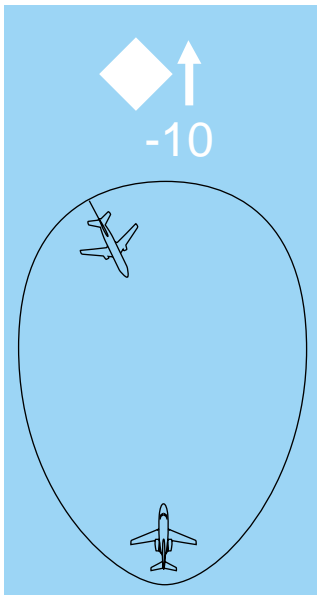
PROXIMITY INTRUDER TRAFFIC

A filled white diamond indicates that the intruding aircraft is within ± 1200 feet and within 6 nm range, but is still not considered a threat.

This intruder is now 1000 feet below your aircraft and climbing at 500 feet per minute or greater.

TRAFFIC ADVISORY (TA)

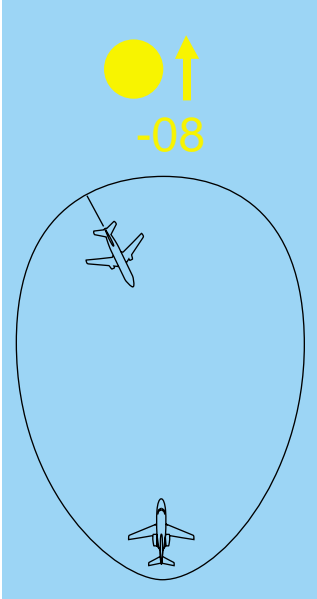

A symbol change to a filled yellow circle indicates that the intruding aircraft is considered to be potentially hazardous. Depending on your own altitude TCAS II will display a TA when time to Closest Point of Approach (CPA) is between 20 and 48 seconds.

Here the intruder is 800 feet below your aircraft, climbing at 500 feet per minute or greater. A voice is heard in the cockpit, advising:

“TRAFFIC, TRAFFIC.”

Under normal conditions a TA will precede an RA by 15 seconds. The crew should attempt to gain visual contact with the intruder and be prepared to maneuver should an RA be sounded 10 to 15 seconds later.

The crew should take no evasive action based solely on the TCAS II traffic display.

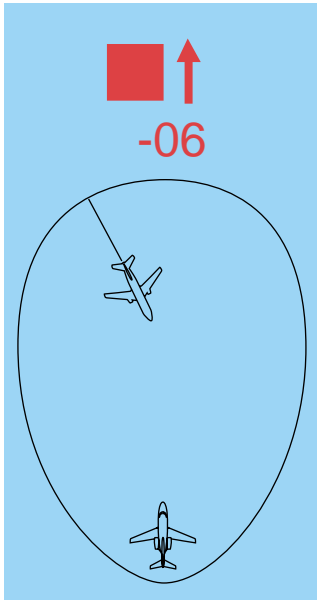
RESOLUTION ADVISORY (RA)

A solid red square indicates that the intruding aircraft is projected to be a collision threat. TCAS II calculates that the intruder has reached a point where a Resolution Advisory is necessary. The time to closest approach with the intruder is now between 15 and 35 seconds depending on your altitude. The symbol appears together with an appropriate audio warning and a vertical maneuver indication on the RA/VSI. Voice announcements are listed later in this section.

Note: For NVIS types only, the intruder symbol appears as a red filled square with white border. Associated altitude and direction arrows are red.

This aircraft is now 600 feet below your altitude and still climbing at 500 feet per minute or greater.

A synthesized voice announces a vertical maneuver command, such as:

“CLIMB, CLIMB, CLIMB.”

The pilot should smoothly but firmly initiate any required vertical maneuver within 5 seconds (2.5 seconds for an “Increase RA” or “Reversal RA”) from the time the RA is posted.

An intruder must be reporting altitude in order to generate an RA. Therefore, the RA symbol will always have an altitude tag.

OFF SCALE TRAFFIC

The presence of TA or RA aircraft that are beyond the selected display range is indicated by one half of the traffic symbol at the edge of the screen. The position of the half-symbol represents the bearing of the intruder.



TA and RA traffic off scale, TCAS Mode Format.

NO BEARING TRAFFIC

In installations with dual directional antenna's with landing gear down or when omni antenna is installed on bottom of the aircraft. If traffic can only be seen by the bottom antenna as described above, a "No Bearing" TA or RA would be annunciated, as shown.



No Bearing TA and RA.

THE RA/VSI INSTRUMENT

TCAS II guidance is incorporated into the vertical speed indicator. Two rows of colored lights, one green and one red, are located around the vertical speed scale. TCAS II uses the green lights to indicate whether to climb, descend or remain level. Red lights indicate where not to climb, descend or remain level. The lights are OFF unless an active Resolution Advisory is in progress.



Resolution Advisories are grouped as Corrective Advisories or Preventive Advisories. Corrective Advisories require a positive action by the crew accompanied by a green arc on the RA/VSI showing “Fly-To” guidance. Preventive Advisories require that NO action be taken to alter the flight path of the aircraft.

When TCAS issues an RA, certain segments in the row of red lights will be turned on. Segments in the row of green lights will be on when the pilot is required to actively maneuver the aircraft to satisfy the resolution. For safe separation from the intruder, the pilot should maneuver the aircraft within the vertical speeds represented by the green lights. Vertical speeds within the red area must be avoided.

An RA may be presented on the VSI requiring avoidance of two or three threat aircraft simultaneously. For example, a “do not descend” indication may be visible at the same time a “limit climb rate” indication appears because of threat aircraft above and below your own aircraft.

THE TAV/SI INSTRUMENT

The TAV/SI combines the plan position of intruding aircraft and TCAS II guidance on the vertical speed instrument.

A pointer and circular vertical speed scale indicate aircraft vertical rate. Climb and descend Resolution Advisories are shown as red and green bands outside of the scale. The center of the display presents intruding traffic. Refer to Section II for a detailed description of the TAV/SI.



HOW TO FLY TYPICAL TCAS II COMMANDS

The Resolution Advisory is incorporated into the Vertical Speed Indicator. By illuminating red and green light bands around the dial, “Fly-To” and “Fly-Away-From” commands are displayed coinciding with the required vertical rate. Maneuver the aircraft promptly and smoothly in response to the Resolution Advisory.

Some of the typical Resolution Advisories shown on the RA/VSI will require a maneuver by the crew while others will warn against maneuvering. A typical TCAS II maneuver requires crew response within 5 seconds and G-forces of $\pm 0.25G$.

The following diagrams illustrate typical TCAS II encounters showing intruder traffic on a display and the corresponding resolution on the RA/VSI.

INDICATIONS AND VOICE ANNOUNCEMENTS**“CLIMB, CLIMB, CLIMB”****Situation:**

The intruder is ahead 4 NM at 12:00 o'clock, 200 feet below your altitude and flying level.

**Crew Response:**

Promptly and smoothly establish a climb rate of 1500 feet per minute.

INDICATIONS AND VOICE ANNOUNCEMENTS

“MONITOR VERTICAL SPEED”

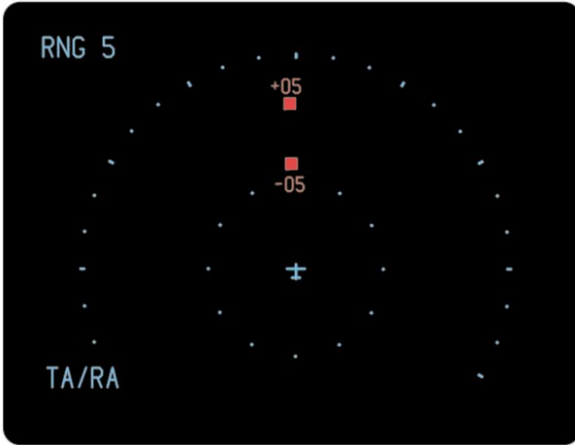

Situation:

One intruder is ahead at 12:00 o'clock, 500 feet above your altitude. Another is at 500 feet below your altitude. Both are in level flight.



Crew Response:

Remain in level flight. Do not climb or descend.

INDICATIONS AND VOICE ANNOUNCEMENTS**“MONITOR VERTICAL SPEED”****Situation:**

The intruder is ahead at 12:00 o'clock, 600 feet below your altitude and flying level.

**Crew Response:**

Do not descend.

INDICATIONS AND VOICE ANNOUNCEMENTS

“TRAFFIC, TRAFFIC”



Situation:

One intruder is ahead at 12:00 o'clock, beyond 5 miles, 200 feet below your altitude.



Crew Response:

You do not maneuver on the Traffic Advisory symbol. Attempt to visually acquire the intruder and be prepared to maneuver if the TA changes to an RA.

INDICATIONS AND VOICE ANNOUNCEMENTS**“MONITOR VERTICAL SPEED”****Situation:**

The intruder is 4 NM ahead at 12:00 o'clock, 400 feet above your altitude and flying level. You are already climbing at 2000 feet per minute.

**Crew Response:**

Maintain climb at present rate.

INDICATIONS AND VOICE ANNOUNCEMENTS

“DESCEND, DESCEND, DESCEND.”



Situation:

One intruder is 4 NM ahead at 12:00 o'clock, 200 feet above your altitude and flying level.



Crew Response:

Promptly and smoothly establish a descent rate of 1500 feet per minute.

INDICATIONS AND VOICE ANNOUNCEMENTS**“CLIMB, CLIMB NOW.”****Situation:**

Alert Increase: The intruder ahead has changed from level flight to a rapid descent after TCAS issued a descend RA. TCAS is now changing that to a climb.

**Crew Response:**

You are expected to initiate the change from a descent to a climb maneuver within 2.5 seconds with an increase in G-force to .35.

INDICATIONS AND VOICE ANNOUNCEMENTS

“CLEAR OF CONFLICT.”



Situation:

The intruder has passed behind and is now 600 feet below your altitude. It is no longer a threat.



Crew Response:

Return promptly to the previous ATC clearance.

RECOVERY AFTER CLEAR OF CONFLICT:

- If initially in level flight, promptly but smoothly return to the previously assigned altitude unless otherwise directed by ATC.
- If climbing or descending resume the planned climb or descent after the intruder has passed by unless otherwise directed by ATC.

AUDIO ANNOUNCEMENTS

Synthesized voice announcements are issued by TCAS II over the aircraft audio system. The following tables list all of the RESOLUTION Advisories, audio messages, and advisories in the TCAS II vocabulary.

AUDIO MESSAGES

CONDITION	ADVISORY MESSAGE
Traffic Advisory	"Traffic, Traffic"*
RA Cleared	"Clear of Conflict"
Self Test Passed	"TCAS System Test OK"
Self Test Failed	"TCAS System Test Fail"

* "Traffic" is spoken once if a second TA appears during an advisory.

RESOLUTION ADVISORIES AND SYNTHESIZED VOICE ANNOUNCEMENTS

RA CATEGORY	CORRECTIVE	PREVENTIVE
Climb	"Climb, Climb, Climb"	"Monitor Vertical Speed,* Monitor Vertical Speed"
Descent	"Descend, Descend, Descend"	"Monitor Vertical Speed,* Monitor Vertical Speed"
Crossover Climb	"Climb, Crossing Climb Climb, Crossing Climb."	"Monitor Vertical Speed,* Monitor Vertical Speed"
Crossover Descent	"Descend, Crossing Descend Descend, Crossing Descend."	"Monitor Vertical Speed,* Monitor Vertical Speed"
Vertical Speed Restricted (Climbing)	"Reduce Climb, Reduce Climb"	"Monitor Vertical Speed,* Monitor Vertical Speed"
Vertical Speed Restricted (Descending)	"Reduce Descent, Reduce Descent."	"Monitor Vertical Speed,* Monitor Vertical Speed"

* "Monitor Vertical Speed" is spoken once if downgraded from a previous corrective advisory.

RA INCREASES AND REVERSALS

The following Resolution Advisories are changes from those previously issued and require two and one-half seconds response time and up to .35G.

RA CATEGORY	CORRECTIVE	PREVENTIVE
Change From Climb to Descent	"Descend, Descend NOW, Descend, Descend NOW"	(N/A)
Change From Descent to Climb	"Climb, Climb NOW, Climb, Climb NOW"	(N/A)
Increase Climb Rate	"Increase Climb, Increase Climb"	(N/A)
Increase Descent Rate	"Increase Descent, Increase Descent"	(N/A)

LIST OF RESOLUTION ADVISORIES

TCAS TRAFFIC ADVISORY ANNUNCIATIONS (TA):

Aural	Visual	Crew Response
"TRAFFIC, TRAFFIC"	Amber filled circle on the TA/VSI and Radar indicator.	Conduct visual search of the intruder. If successful, maintain visual acquisition to ensure safe operation

TCAS RESOLUTION ADVISORY ANNUNCIATIONS (RA):

Aural	Visual	Crew Response
"CLIMB, CLIMB, CLIMB"	VSI RED from -6000 FPM to +1500 FPM and GREEN from +1500 FPM to +2000 FPM.	Promptly and smoothly establish a 1500 FPM CLIMB as indicated by the GREEN arc on the VSI display.
"DESCEND, DESCEND, DESCEND"	VSI RED from +6000 FPM to -1500 FPM and GREEN from -1500 FPM to -2000 FPM.	Promptly and smoothly establish a 1500 FPM DESCENT as indicated by the GREEN arc on the VSI display.
"MONITOR VERTICAL SPEED, MONITOR VERTICAL SPEED"	Present vertical speed is outside the RED arc as shown on the VSI.	Keep vertical speed out of the RED, unsafe area as indicated on the VSI.
"REDUCE CLIMB, REDUCE CLIMB"	VSI indicates prohibited vertical speed in RED. GOAL is vertical speed in GREEN.	Promptly and smoothly reduce vertical speed to that shown in the GREEN arc as indicated on the VSI display.
"CLIMB, CROSSING CLIMB, CLIMB, CROSSING CLIMB"	Same as "CLIMB" and further indicates that own flight path will cross that of intruder.	Promptly and smoothly establish a 1500 FPM CLIMB as indicated by the GREEN arc on the VSI display.

"DESCEND, CROSSING DESCEND, DESCEND, CROSSING DESCEND"	Same as "DESCEND" and further indicates that own flight path will cross that of intruder.	Promptly and smoothly establish a 1500 FPM DESCENT as indicated by the GREEN arc on the VSI display.
"CLEAR OF CONFLICT"	VSI RED and GREEN arcs removed. Range is increasing, and is adequate.	Promptly and smoothly return to assigned altitude.
"INCREASE CLIMB, INCREASE CLIMB"	Follows a "CLIMB" advisory. VSI RED from -6000 FPM to +2500 FPM and GREEN from +2500 FPM to +3500 FPM.	Indicates the vertical speed MUST BE INCREASED to ensure adequate separation. Promptly and smoothly establish a 2500 FPM CLIMB as indicated by the GREEN arc on the VSI display.
"INCREASE DESCENT, INCREASE DESCENT"	Follows a "DESCEND" advisory. VSI RED from +6000 FPM to -2500 FPM and GREEN from -2500 FPM to -3500 FPM.	Indicates the vertical speed MUST BE INCREASED to ensure adequate separation. Promptly and smoothly establish a 2500 FPM DESCENT as indicated by the GREEN arc on the VSI display.
"CLIMB, CLIMB NOW, CLIMB, CLIMB NOW"	Follows a "DESCEND" advisory when it has been determined that a reversal of vertical speed (direction) is needed to provide adequate separation.	Promptly and smoothly establish a 1500 FPM CLIMB as indicated by the GREEN arc on the VSI display.
"DESCEND, DESCEND NOW, DESCEND, DESCEND NOW"	Follows a "CLIMB" advisory when it has been determined that a reversal of vertical speed (direction) is needed to provide adequate separation.	Promptly and smoothly establish a 1500 FPM DESCENT as indicated by the GREEN arc on the VSI display.

Intentionally left blank

SECTION II: CONTROLS AND DISPLAYS

SECTION II DESCRIBES CONTROLS AND DISPLAYS OF THE TCAS II EQUIPMENT.

Intentionally left blank

TRANSPONDER/ TCAS CONTROL UNIT; CTA 81A; CTA 81B, CTA 81C, CTA 81D

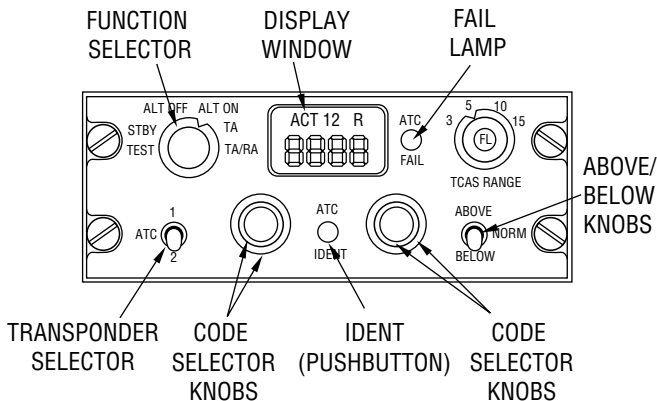

CTA 81A & D Dual Mode S/TCAS Control Unit, CTA 81C Single Mode S/TCAS Control Unit (CTA 81A shown)

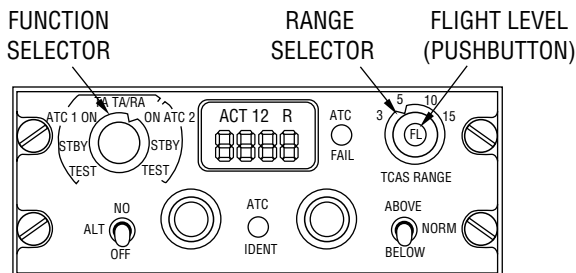

CTA 81B Mode S/ATCRBS/TCAS Control Unit

CTA 81A, CTA 81B CTA 81C AND CTA 81D CONTROLS AND DISPLAYS

The CTA 81 () Control Unit is the control for both the TCAS system and transponder. The CTA 81A/D controls two Mode S transponders. The CTA 81B controls one Mode S transponder and one ATCRBS ARINC 572 transponder. The CTA-81C controls one Mode S transponder.

Note: Controls vary depending on CTA 81 () configuration installed. Control functions same as typical unit shown.

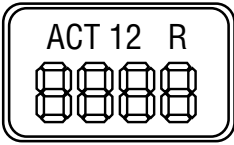

The **Display Window** displays the 4096 ATC code selection and whether transponder No. 1 or No. 2 is active. The letter R blinks on the CTA 81B when indicating the interrogation reply of ATCRBS transponder only.

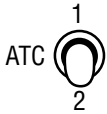

ATC 1-2 selects the active transponder. The other unit is placed in standby.



ALT ON/OFF turns altitude source ON or OFF.

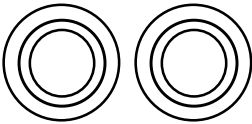

Concentric knobs select the 4096 ATC code in the display window.



The **ATC FAIL** Lamp indicates failure of the selected transponder.



(Pushbutton)

The **ATC IDENT** pushbutton is used to initiate the IDENT feature for ATC.

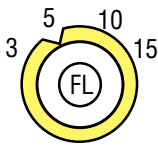

The **TCAS RANGE** Selector is used to select the range on the traffic display. The range is in nautical miles. *(Note: This feature may be superseded by a range control on the traffic display bezel in some installations.)*

Note: Range selection is dependent upon the dash numbers of the control panel.

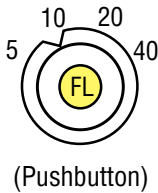

The **FL** (Flight Level) pushbutton (Center of TCAS Range Knob) replaces intruder's relative altitude with absolute altitude in flight level format for 15 seconds. During this period your own altitude, expressed as flight level, is displayed. After 15 seconds flight level reverts back to relative altitude.

The FL function is flagged below 18,000 feet MSL on most traffic displays (FL is flagged on the IVA 81A/C/D, but not on the Radar Indicator when used with GC 362A), unless barometric corrected altitude is available from an air data source.

If FL is selected while inhibited, "FL—" will replace own flight level.

The **A/B** (Above/Below) toggle switch selects the altitude limits for the traffic display. The Above/Below selection has no effect on the TCAS II logic giving TAs and RAs. Three levels to choose from.



ABOVE 8700 feet above; 2700 feet below. Typically used during climb phase of flight.

NORMAL 2700 feet above; 2700 feet below. Typically used during en route phase of flight.

BELOW 2700 feet above; 8700 feet below. Typically used during descent phase of flight.

FUNCTION SELECTOR CTA 81A/C/D CONTROL UNIT ONLY (SELECTS OPERATING MODE)

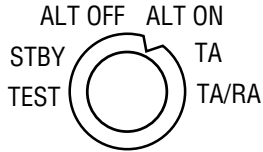

Moving the spring loaded knob to TEST position for one second initiates a comprehensive self test lasting approximately eight seconds. Refer to the Test section in the Appendix for a detailed description of test functions.

STBY places Mode S transponder and TCAS system in standby. Use this position during ground operations.

ALT OFF activates Mode S transponder without altitude reporting, TCAS system in standby.

ALT ON activates Mode S transponder with altitude reporting, TCAS system in standby.

TA (Traffic Advisory) mode. Presents traffic location on TA display but does not issue RAs (Resolution Advisories). A "TA ONLY" mode annunciation appears on the displays. The Mode S transponder and altitude reporting are active.

TA/RA (Traffic Advisory and Resolution Advisory) mode. Presents traffic location on displays and issues audio and visual RAs (Resolution Advisories) for traffic determined to be a threat. The Mode S transponder and altitude reporting are active.

**FUNCTION SELECTOR CTA 81 B CONTROL UNIT ONLY
(SELECTS OPERATING MODE)**

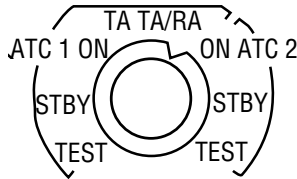

There are no TCAS functions on the ATC 2 (3 most clockwise) positions. The left ATC 1 TEST position (CCW) tests the Mode S Transponder and the TCAS system. The right ATC 2 TEST position (CW) tests the ATCRBS transponder only.

Moving the spring loaded knob to either TEST position initiates a self test in the respective unit. Refer to the Test section in the Appendix for a detailed description of test function.

Selection of either STBY position places both transponders and TCAS II system in standby. Use standby during ground operations.

ATC 1 ON activates the Mode S transponder. TCAS in Standby.

ON ATC 2 activates the ATCRBS transponder. TCAS in standby.

TA (Traffic Advisory) mode. Presents traffic location on displays but does not issue Resolution Advisories. TA mode annunciation appears on displays. Mode S transponder activated with altitude reporting.

TA/RA (Traffic Advisory and Resolution Advisory) mode. Presents traffic location on displays and issues audio visual Resolution Advisories for traffic determined to be a threat. TA/RA mode annunciation appears on PPI or ITA 81A displays. Mode S transponder activated with altitude reporting.

KFS 578A TRANSPONDER/ TCAS CONTROL UNIT

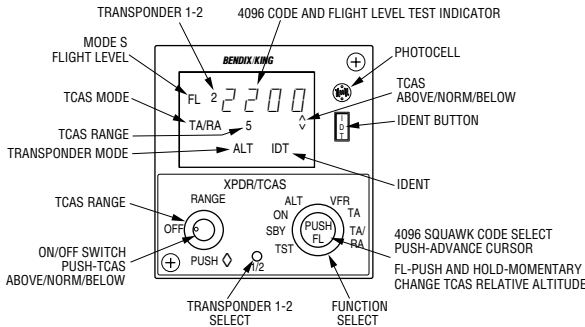

KFS 578A Single or Dual Mode S/TCAS Control Unit (Dual Unit shown).

KFS 578A CONTROLS AND DISPLAYS

The KFS 578A Control Unit is the master control for both the TCAS system and transponder. The KFS 578A will also display the selected 4096 ATC code and current mode of operation in the display window. Versions are available to control one or two transponders. A “Fail” annunciation indicates failure of the selected transponder, antenna or control data.

Note: If the KFS 578A is interfaced to a MST 67A Mode S transponder and the MST 67A senses a failure, a failure annunciation will be shown. A maintenance check should be performed.

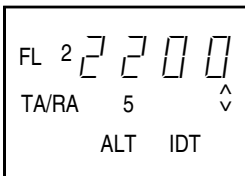

The **Display Window** Displays ATC code selection, whether transponder #1 or #2 is active, transponder mode, transponder ident, own aircraft flight level (in TEST), TCAS mode, TCAS range and TCAS above, below or normal vertical display limit selected.



(Pushbutton)

1/2 selects the active transponder. The other unit is placed in standby.



(Pushbutton)

IDT initiates IDENT feature for ATC.

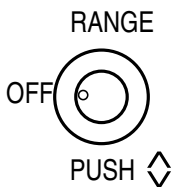

The outer knob on the left hand dual concentric switch selects the Traffic Advisory display range in nautical miles. The selected range is annunciated on the traffic display. The range annunciation is the maximum displayed range to the front of the aircraft. The selected range has no effect on the TCAS II logic giving TAs and RAs.

Note: Selected range is displayed in the upper right hand corner of a TA/VS1.

The inner concentric knob on the left may include an on/off switch (clockwise = on) and when pushed selects Traffic Advisory altitude display limits (Above, Normal or Below). The Above/Below select knob has no effect on the TCAS II logic giving TAs and RAs.

ABOVE 8700 feet above (9000 Change 7 or later); 2700 feet below. Typically used during climb phase of flight.

NORMAL 2700 feet above; 2700 feet below. Typically used during en route phase of flight.

BELOW 2700 feet above; 8700 feet below (9000 Change 7 or later). Typically used during descent phase of flight.

Note: All knobs are continuous rotatory and do not roll over or stop.

KFS 578A FUNCTION SELECTOR, ATC CODE SELECT & MOMENTARY TCAS DISPLAY FLIGHT LEVEL SELECT

The outer concentric knob on the right selects the Mode S and TCAS mode of operation.

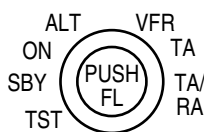

Rotating the function knob (CCW) to the TST position initiates a comprehensive self test lasting approximately eight seconds. All segments of the display are illuminated for 2 seconds, then the code window will display the encoded altitude for four seconds, then the control unit will return to the previously selected mode. (Refer to the Test section in the Appendix for a detailed description of test functions.)

Controls and Displays

SBY places the Mode S Transponder and TCAS in standby. SBY is annunciated on the display window. Use SBY during ground operations.

ON activates the selected transponder without altitude reporting. TCAS is in standby. ON is annunciated in the display window.

ALT activates Mode S transponder with altitude reporting, TCAS system in standby.

Selecting **VFR** for more than 3 seconds changes the ATC code to the pre-programmed VFR code (Typically 1200). VFR is annunciated in the display window for the 3 seconds prior to switching the programmed code. The control unit will return to the mode selected prior to making the VFR selection.

The VFR code can be programmed to be any code by the following technique:

- a. Place the function selector to VFR.
- b. Select the VFR code as required.
- c. Push the Ident (IDT) button, or wait 3 seconds, or rotate the Function switch to the desired mode.

The **TA** (Traffic Advisory) mode. Activates the Mode S transponder, altitude reporting and TCAS "TA ONLY" mode. Traffic will be presented on the traffic (TA) display but no RAs (Resolution Advisories) will be issued. "TA" mode is annunciated in the control unit display window and "TA ONLY" will be annunciated on the TCAS traffic display(s).

The traffic display switches to the FL (flight level) display function when the inner knob is pressed in for more than four seconds. The relative altitude tags are replaced with absolute altitude (FL) tags. The traffic display will revert to relative altitude after 15 seconds.

The FL feature is usually flagged below 18,000 feet MSL unless barometric corrected altitude is available from an air data source. FL is flagged on the IVA 81A but not on the radar indicator when used with the GC 362A, traffic displays. If FL is selected while flagged, "FL---" is annunciated instead of own flight level.

TA/RA (Traffic Advisory and Resolution Advisory) mode. Activates the Mode S transponder, altitude reporting, and TCAS "TA/RA" mode. Aural and visual RAs (Resolution Advisories) will be issued for traffic determined to be a threat. Traffic will be presented on the traffic (TA) display. TA/RA mode is annunciated in the display window, on the optional color radar indicator or dedicated traffic display.

PS 578A TRANSPONDER/TCAS CONTROL UNIT

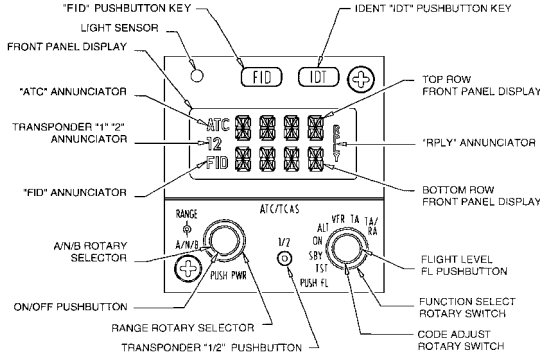

PS 578A Single or Dual Mode S/TCAS Control Unit (Dual Unit shown).

PS 578A CONTROLS AND DISPLAYS

The PS 578A Control Unit is the master control for both the TCAS system and transponder. The PS 578A will also display the selected 4096 ATC code and current mode of operation in the display window. Versions are available to control one or two transponders. A "Fail" annunciation indicates failure of the selected transponder, antenna or control data.

Note: If the PS 578A is interfaced to a MST 67A Mode S transponder and the MST 67A senses a failure, a failure annunciation will be shown. A maintenance check should be performed.

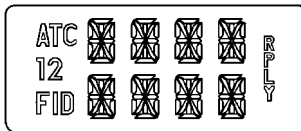

The **Display Window** Displays ATC code selection, Flight ID (FID) selection, whether transponder #1 or #2 is active, transponder mode, transponder ident, own aircraft flight level (in TEST), TCAS mode, TCAS range and TCAS above, below or normal vertical display limit selected.

Controls and Displays

1/2



1/2 selects the active transponder. The other unit is placed in standby.

(Pushbutton)



IDT initiates IDENT feature for ATC.

(Pushbutton)



FID allows entry of an alphanumeric flight identification. Selecting the right inner pushbutton will cycle through the eight characters to be changed. Rotating the right inner knob will change the contents of the selected (flashing) character.

(Pushbutton)

RANGE



A/N/B

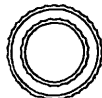

PUSH PWR

The outer knob on the left hand dual concentric switch selects the Traffic Advisory display range in nautical miles. The selected range is annunciated on the traffic display. The range annunciation is the maximum displayed range to the front of the aircraft. The selected range has no effect on the TCAS II logic giving TAs and RAs.

Note: Selected range is displayed in the upper right hand corner of a TAWSI.

The inner concentric knob on the left includes an on/off switch (push on/off) and when rotated selects Traffic Advisory altitude display limits (Above, Normal or Below). The Above/Normal/Below select knob has no effect on the TCAS II logic giving TAs and RAs.

ABOVE 8700 feet above (9000 Change 7 or later); 2700 feet below. Typically used during climb phase of flight.

NORMAL 2700 feet above; 2700 feet below. Typically used during en route phase of flight.

BELOW 2700 feet above; 8700 feet below (9000 Change 7 or later). Typically used during descent phase of flight.

Note: All knobs are continuous rotary and do not roll over or stop.

PS 578A FUNCTION SELECTOR, ATC CODE SELECT & MOMENTARY TCAS DISPLAY FLIGHT LEVEL SELECT



The outer concentric knob on the right selects the Mode S and TCAS mode of operation.

Rotating the function knob (CCW) to the TST position initiates a comprehensive self test lasting approximately eight seconds. All segments of the display are illuminated for 2 seconds, then the code window will display the encoded altitude for four seconds, then the control unit will return to the previously selected mode. (Refer to the Test section in the Appendix for a detailed description of test functions.)

SBY places the Mode S Transponder and TCAS in standby. SBY is annunciated on the display window. Use SBY during ground operations.

ON activates the selected transponder without altitude reporting. TCAS is in standby. ON is annunciated in the display window.

ALT activates Mode S transponder with altitude reporting, TCAS system in standby.

Selecting **VFR** for more than 3 seconds changes the ATC code to the pre-programmed VFR code (Typically 1200). VFR is annunciated in the display window for the 3 seconds prior to switching the programmed code. The control unit will return to the mode selected prior to making the VFR selection.

The VFR code can be programmed to be any code by the following technique:

- a. Place the function selector to VFR.
- b. Select the VFR code as required.
- c. Push the Ident (IDT) button, or wait 3 seconds, or rotate the Function switch to the desired mode.

The **TA** (Traffic Advisory) mode. Activates the Mode S transponder, altitude reporting and TCAS "TA ONLY" mode. Traffic will be presented on the traffic (TA) display but no RAs (Resolution Advisories) will be issued. "TA" mode is annunciated in the control unit display window and "TA ONLY" will be annunciated on the TCAS traffic display(s).

Controls and Displays

The traffic display switches to the FL (flight level) display function when the inner knob is pressed in for more than four seconds. The relative altitude tags are replaced with absolute altitude (FL) tags. The traffic display will revert to relative altitude after 15 seconds.

The FL feature is usually flagged below 18,000 feet MSL unless barometric corrected altitude is available from an air data source. FL is flagged on the IVA 81A but not on the radar indicator when used with the GC 362A, traffic displays. If FL is selected while flagged, "FL---" is announced instead of own flight level.

TA/RA (Traffic Advisory and Resolution Advisory) mode. Activates the Mode S transponder, altitude reporting, and TCAS "TA/RA" mode. Aural and visual RAs (Resolution Advisories) will be issued for traffic determined to be a threat. Traffic will be presented on the traffic (TA) display. TA/RA mode is annunciated in the display window, on the optional color radar indicator or dedicated traffic display.

CD 671C TRANSPONDER/ TCAS CONTROL UNIT

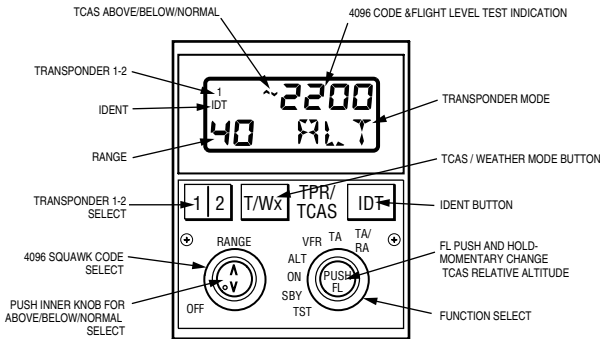

CD 671C Single or Dual Mode S/TCAS Control Unit (Dual Unit shown).

CD 671C CONTROLS AND DISPLAYS

The CD 671C Control Unit is the master control for both the TCAS system and transponder. The CD 671C will also display the selected 4096 ATC code and current mode of operation in the display window. Versions are available to control one or two transponders. A "Fail" annunciation indicates failure of the selected transponder, antenna or control data.

Note: If the CD 671A is interfaced to a MST 67A Mode S transponder and the MST 67A senses a failure, a failure annunciation will be shown. A maintenance check should be performed.



The **Display Window** displays the ATC code selection, whether transponder #1 or #2 is active, transponder mode, transponder ident, own aircraft flight level (in TEST), TCAS mode, TCAS range and TCAS above, below or normal vertical display limit selected.

All display annunciations are seen during the control unit self-test. The "R" annunciation is only seen during self-test. "FL" on the control unit is only displayed during self-test and indicates the transponder's encoded altitude. Continuous FL mode is selected by activating Ext. SBY discrete and turning mode knob to "TST"

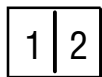

The 1/2 push button selects No. 1 or No. 2 as the active transponder. The other unit is placed in standby. The Display Window shows which transponder is the active source.



The IDT push button initiates the IDENT feature for ATC. The IDENT function is used at the request of an Air Traffic Controller, and holds the Ident reply for 18 ± 1 seconds.

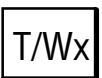

The T/Wx (TCAS/Weather) mode button is necessary in installations using the weather radar indicator as the traffic display. In these installation, the T/Wx switch is used to select between Weather Only, Weather with TCAS Traffic and Traffic Only modes.

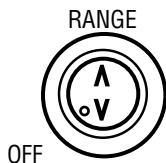

The outer knob selects the traffic display range in nm (nautical miles). This knob can select 3, 5, 10, 15, 20 or 40 nm range on the TCAS traffic display. The range is displayed in the display window during range selection.

Note: The Range knob is continuous rotary and does not roll over or stop.

Controls and Displays

The traffic display may have another range select source. The selected TCAS range is always annunciated on the traffic display. The range annunciated is the maximum displayed range to the front of the aircraft. The range to the rear is 1/2 the annunciated range. The selected range has no effect on the TCAS logic giving TAs or RAs.

The inner concentric knob may include an optional ON/OFF switch; clockwise is ON. When the inner knob is pushed, the Traffic Advisory altitude (Above/Norm/Below) display limits are sequentially selected. There are three display levels to choose from.

ABOVE; 8700 feet above (9000 Change 7 or later) and 2700 feet below, is typically used during the climb phase of flight. A "∧" (carat) will be annunciated in the display window.

NORMAL; 2700 feet above and 2700 feet below, is used during the enroute phase of flight. Both the "∧" and "∨" (carats) will be annunciated in the display window.

BELOW; 2700 feet above and 8700 feet below (9000 Change 7 or later), is used during the descent phase of flight. A "∨" (carat) will be annunciated in the display window.

The Above/Below selection has no effect on the TCAS logic giving TAs and RAs.

CD671A FUNCTION SELECTOR, ATC CODE SELECT & MOMENTARY TCAS DISPLAY FLIGHT LEVEL SELECT

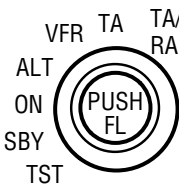

The dual concentric knobs on the right side of the unit are used to select the ATC code & TCAS/Transponder mode and the TCAS flight level feature. The outer concentric knob selects the Mode S and TCAS mode of operation. The mode is annunciated in the display window.

TST Rotating the outer function knob (CCW) to the TST position initiates a comprehensive self-test lasting approximately eight seconds. All segments of the display are illuminated for 2 seconds, then the code window will display the encoded altitude for four seconds, then the control unit will return to the previously selected mode.

SBY places the Mode S Transponder and TCAS in standby. SBY is annunciated in the display window. Use standby during ground operations.

ON activates the selected transponder without altitude reporting. TCAS is in standby. ON is annunciated in the display window.

ALT Activates Mode S transponder with altitude reporting, TCAS system in standby.

VFR Selecting VFR for more than 3 seconds changes the ATC code to the pre-programmed VFR code (typically 1200). VFR is annunciated in the display window for the 3 seconds before switching to the programmed code. The control unit will return to the mode selected prior to making the VFR selection. The VFR code can be programmed to any code by the following technique:

1. Place the function selector to VFR.
2. Select the VFR code as required.
3. Push the Ident (IDT) button, or wait 3 seconds, or rotate the Function switch to the desired mode.

TA (TA Traffic Advisory) mode. TA activates the Mode S transponder, altitude reporting and TCAS "TA ONLY" mode. Traffic will be presented on the traffic (TA) display. "TA" mode is annunciated in the control unit display window and "TA ONLY" will be annunciated on the TCAS traffic display(s).

The inner concentric knob on the right selects the 4096 ATC code and when pushed and held for more than four seconds switches the TCAS traffic display to the FL (flight level) display function. To select an ATC code, momentarily push this knob to start the left hand digit in the ATC code flashing, twist the knob to change the number. Momentarily push the knob again to move the flashing digit one space to the right and twist the knob to change the digit. Repeat for the third and fourth digit of the ATC code. The flashing digit will stop flashing 3 seconds after the last change.

The traffic display switches to the FL (flight level) display function when the inner knob is pressed in for more than four seconds. The relative altitude tags are replaced with absolute altitude (FL) tags. The traffic display will revert to relative altitude after 15 seconds.

Controls and Displays

The FL feature is usually flagged below 18,000 feet MSL unless barometric corrected altitude is available from an air data source. FL is flagged on the IVA 81A but not on the radar indicator when used with the GC 362A, traffic displays. If FL is selected while flagged, "FL----" is annunciated instead of own flight level.

TA/RA (Traffic Advisory and Resolution Advisory) mode. Activates the Mode S transponder, altitude reporting, and TCAS "TA/RA" mode. Aural and visual RAs (Resolution Advisories) will be issued for traffic determined to be a threat. Traffic will be presented on the traffic (TA) display. TA/RA mode is annunciated in the display window, on the optional color radar indicator or dedicated traffic display.

PS 550 TRANSPONDER/ TCAS CONTROL UNIT

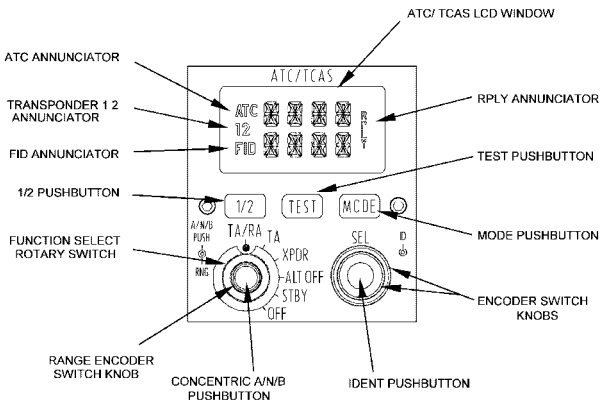

PS 550 Single or Dual Mode S/TCAS Control Unit (Dual Unit shown).

PS 550 CONTROLS AND DISPLAYS

The PS 550 Control Unit is the master control for both the TCAS system and transponder. The PS 550 will also display the selected 4096 ATC code and current mode of operation in the display window. Versions are available to control one or two transponders. A "Fail" annunciation indicates failure of the selected transponder, antenna or control data.

Note: If the PS 550 is interfaced to a MST 67A Mode S transponder and the MST 67A senses a failure, a failure annunciation will be shown. A maintenance check should be performed.

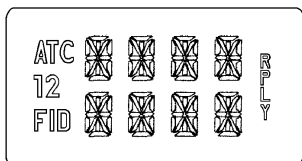

The **Display Window** displays the ATC code selection, whether transponder #1 or #2 is active, transponder mode, transponder ident, own aircraft flight level (in TEST), TCAS mode, TCAS range and TCAS above, below or normal vertical display limit selected.

All display annunciations are seen during the control unit self-test.



The 1/2 push button selects No. 1 or No. 2 as the active transponder. The other unit is placed in standby. The Display Window shows which transponder is the active source.



The TST push button initiates a comprehensive self-test lasting approximately eight seconds. All segments of the display are illuminated for 2 seconds, then the code window will display the encoded altitude for four seconds.



The MODE push button sequentially selects the ATC, TFC or FL mode, FID and ADC.

ATC Mode - Allows entry of the four digit ATC code.

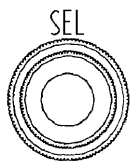

Honeywell MST 67A configuration: The right outer knob selects each of the four positions for entry, and the right inner knob selects the content.

Collins TDR-94D configuration: The right outer knob enters the first two digits and the right inner knob enters the last two digits.

TFC Mode - (*Collins TDR-94D only*) Allows selection of the traffic display operating mode (AUTO - data Pop-up or ON - full time display).

FL Mode - (*Honeywell MST-67A only*) Allows selection of relative or absolute altitude for display. The relative altitude tags are replaced with absolute altitude (FL) tags. The traffic display will revert to relative altitude after 15 seconds

The FL feature is usually flagged below 18,000 feet MSL unless barometric corrected altitude is available from an air data source. FL is flagged on the IVA 81A but not on the radar indicator when used with the GC 362A, traffic displays. If FL is selected while flagged, "FL---" is annunciated instead of own flight level.

Controls and Displays

FID Mode - Allows entry of the eight digit alphanumeric flight ID code. The right outer knob selects each of the eight positions for entry, and the right inner knob selects the alphanumeric character.

ADC Mode - Allows selection of the air data computer used by the TCAS.

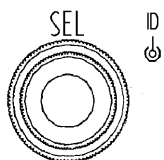

The ID push button in the center of the Code Selector knob initiates the IDENT feature for ATC. The IDENT function is used at the request of an Air Traffic Controller, and holds the Ident reply for 18 ± 1 seconds.

PS 550 FUNCTION SELECTOR, TCAS RANGE SELECT & TCAS ALTITUDE LIMITS SELECT

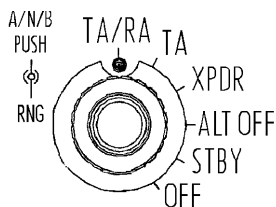

The dual concentric knobs on the left side of the unit are used to select the TCAS/Transponder mode, the TCAS range and the TCAS altitude limits. The outer concentric knob selects the Mode S and TCAS mode of operation. The mode is annunciated in the display window.

STBY places the Mode S Transponder and TCAS in standby. SBY is annunciated in the display window. Use standby during ground operations.

ALT OFF activates the selected transponder without altitude reporting. TCAS is in standby. ON is annunciated in the display window.

XPDR Activates Mode S transponder with altitude reporting, TCAS system in standby.

TA (TA Traffic Advisory) mode. TA activates the Mode S transponder, altitude reporting and TCAS "TA ONLY" mode. Traffic will be presented on the traffic (TA) display. "TA" mode is annunciated in the control unit display window and "TA ONLY" will be annunciated on the TCAS traffic display(s).

TA/RA (Traffic Advisory and Resolution Advisory) mode. Activates the Mode S transponder, altitude reporting, and TCAS "TA/RA" mode. Aural and visual RAs (Resolution Advisories) will be issued for traffic determined to be a threat. Traffic will be presented on the traffic (TA) display. TA/RA mode is annunciated in the display window, on the optional color radar indicator or dedicated traffic display.

The inner knob selects the traffic display range in nm (nautical miles). This knob can select 3, 5, 10, 15, 20 or 40 nm range on the TCAS traffic display. The range is displayed in the display window during range selection.

Note: The Range knob is continuous rotary and does not roll over or stop.

The traffic display may have another range select source. The selected TCAS range is always annunciated on the traffic display. The range annunciated is the maximum displayed range to the front of the aircraft. The range to the rear is either full annunciated range or 1/2 the annunciated range, depending on the display. The selected range has no effect on the TCAS logic giving TAs or RAs.

When the inner knob is pushed, the Traffic Advisory altitude (Above/Norm/Below) display limits are sequentially selected. There are three display levels to choose from.

ABOVE; 8700 feet above (9000 Change 7 or later) and 2700 feet below, is typically used during the climb phase of flight. A "^" (carat) will be annunciated in the display window.

NORMAL; 2700 feet above and 2700 feet below, is used during the enroute phase of flight. Both the "^" and "v" (carats) will be annunciated in the display window.

BELOW; 2700 feet above and 8700 feet below (9000 Change 7 or later), is used during the descent phase of flight. A "v" (carat) will be annunciated in the display window.

The Above/Below selection has no effect on the TCAS logic giving TAs and RAs.

**WEATHER RADAR INDICATORS;
RDS 81, 82, 84 & 86, PRIMUS COLOR INDICATORS
200/300SL/400/870/P90/650/800 AND COLLINS
WXR 300 (IND-270)**

The GC 362A TCAS Graphic Processor allows TCAS traffic to be displayed on Bendix/King RDS series Radar indicators or Honeywell Primus Color Radar indicators or the Collins IND-270 indicators. Most of the controls are on the Mode S/TCAS control panel; however, a remote mounted Mode Select button is required to switch between Radar Only display, Radar with TCAS traffic overlay display and TCAS only display.

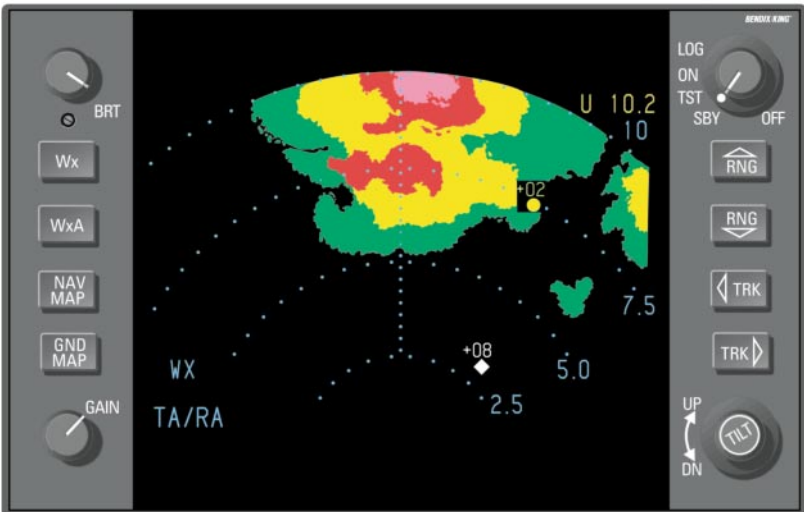

RADAR ONLY MODE

In this mode of operation, only weather radar information is displayed until a Traffic Advisory or Resolution Advisory is issued by the TCAS Processor. The range is controlled by the weather radar range control in this mode of operation. When a Traffic or Resolution advisory occurs the display will revert to the default TCAS display (either TCAS Only or Radar/TCAS Overlay) selected by the pop-up default discrete. When the advisory is removed, the display will revert back to the weather radar display. This mode is annunciated by TA/RA AUTO or TA AUTO in the lower left hand corner of the screen.

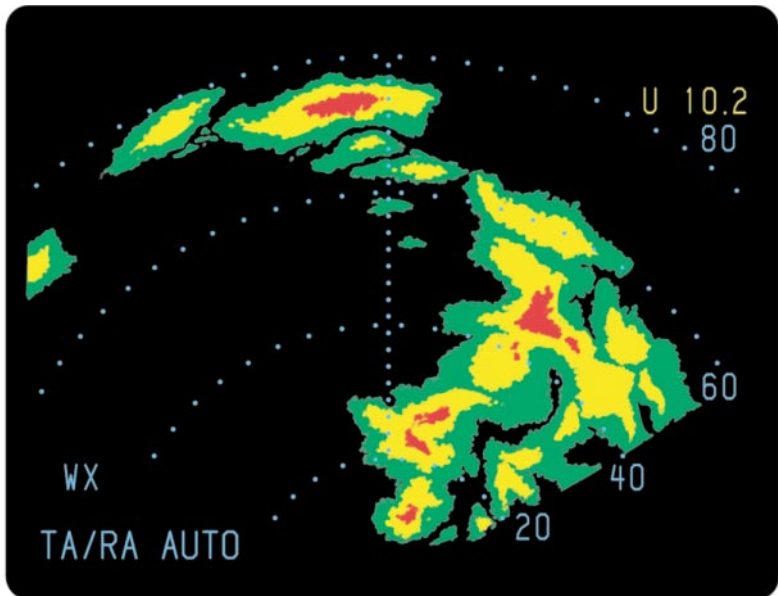

RADAR WITH TCAS OVERLAY MODE

A full time TCAS display overlays the weather display in this mode. The display origin is at the bottom of the screen; however, if a Bendix/King RDS series Radar with a GC 360A Graphics Controller is also installed, the display can be referenced to the center of the screen, giving a 360° display. Weather will be displayed in the upper 90° or 120° sector, depending on which radar is being used. Weather is blanked in the areas where TCAS traffic is displayed. The range displayed in this mode is that which was selected for weather radar. If weather radar is in the standby mode or other non-radar mode, the display will be the same as that in the TCAS Only mode. This mode is maintained unless another mode is manually selected. The TCAS operational mode is annunciated in addition to WX that annunciates the weather mode in the lower left hand corner of the screen unless the radar is in standby, in which case the TCAS mode is displayed in the upper right hand corner.

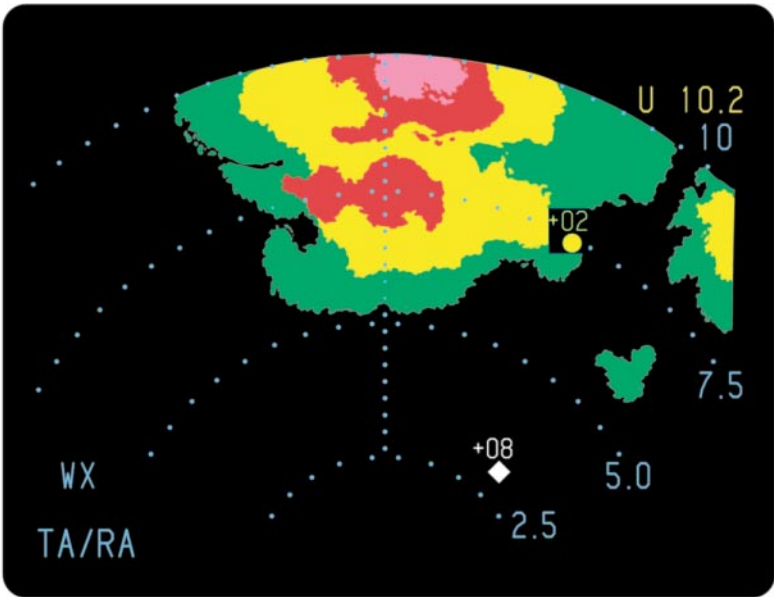

TCAS ONLY MODE

In this mode the screen's origin point is 1/3 up from the bottom of the screen. Only TCAS information is displayed. This mode is maintained unless another mode is manually selected. The range displayed is controlled by the TCAS control panel. A 2 nm range ring is displayed on ranges 3, 5, 10, and 15 nm. The 2 nm range ring consists of discrete dots (cyan) at each of the 12 clock positions. The 2 nm range ring is not displayed on ranges 20 and 40 nm; instead a half-range ring is displayed. The half-range ring consists of discrete dashes (cyan). The TCAS operational mode is annunciated in the lower left hand corner of the screen.

Options to these displays can exist. Example: the 10 and 15 nm ranges could have 2 nm and 5 nm range rings. The 40 nm range could have 2, 5, and 20 nm range rings. The outer range might also have cardinal heading identification. These options are dependent on the part number of the GC 362 used.



Note: On the "TCAS ONLY" display, "WX ON" will be annunciated in the upper right hand corner if the weather radar is transmitting. See Weather Radar operating guide.

At power-up the screen initially displays the Radar with TCAS Overlay mode. When the Test mode is selected on the Mode S/TCAS control panel the self-test pattern is displayed unless TCAS system failures are detected. If system failures are detected the screen is blanked and a list of faults is displayed.

Controls and Displays

The presence of a TA or RA aircraft that is beyond the selected display range is indicated by one half of the traffic symbol at the edge of the screen. The position of the half-symbol represents the bearing of the intruder.



TA and RA traffic off scale, 5 mile range, TCAS Only Mode.



Same traffic on 10 mile range, TCAS Only Mode.

WEATHER MODES MESSAGE FORMAT***TCAS MODE ANNUNCIATIONS:***

TCAS STBY	(Blue)	TCAS in Standby
TEST	(Blue)	TCAS in TEST
TA/RA	(Blue)	TA/RA Mode
TA/RA AUTO	(Blue)	TA/RA Pop-Up
TA ONLY	(Blue)	TA ONLY Mode
TA AUTO	(Blue)	TA ONLY Pop-Up

Note: When the Radar is placed in standby the TCAS mode annunciation is moved to the upper right hand corner.

TCAS FAULT ANNUNCIATIONS:

(switch to TCAS ONLY mode for list of faults)

NO TCAS	(Blue)	TCAS not operational.
TCAS FAIL	(Yellow)	TCAS Failure.
GP FAIL	(Yellow)	GC362A Failure.

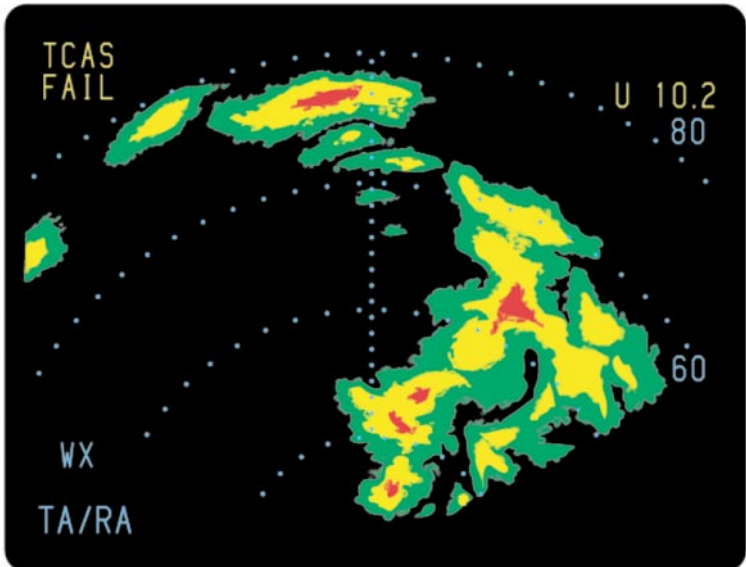

TCAS MODE MESSAGE FORMAT

TCAS MODE ANNUNCIATIONS:

TCAS STBY	(Blue)	TCAS in Standby
TEST	(Blue)	TCAS in TEST
TA/RA	(Blue)	TA/RA Mode
TA/RA AUTO	(Blue)	TA/RA Pop-Up
TA ONLY	(Blue)	TA ONLY Mode
TA AUTO	(Blue)	TA ONLY Pop-Up

TCAS FAULT ANNUNCIATIONS:

NO TCAS	(Blue)	TCAS not operational
TCAS FAIL	(Yellow)	TCAS Failure
GP FAIL	(Yellow)	GC 362A Failure



FAULT MESSAGE FORMAT***FAULT ANNUNCIATIONS:***

TCAS PROCESSOR	SELECTED XPNDR
UPPER ANTENNA	XPNDR TOP ANTENNA
LOWER ANTENNA	XPNDR LOWER ANTENNA
RADIO ALT #1	XPNDR TCAS DATA
RADIO ALT #2	XPNDR CONTROL DATA
RADIO ALT #1 & #2	XPNDR ALT DATA #1 & #2
#1 XPNDR DATA BUS	#1 XPNDR ALT DATA
#2 XPNDR DATA BUS	#2 XPNDR ALT DATA
TRAFFIC DISPLAY #1	ATTITUDE
TRAFFIC DISPLAY #2	HEADING
RA DISPLAY #1 & #2	GP RAM
RA DISPLAY #1	NO RADAR 429 DATA
RA DISPLAY #2	NO TCAS 429 DATA

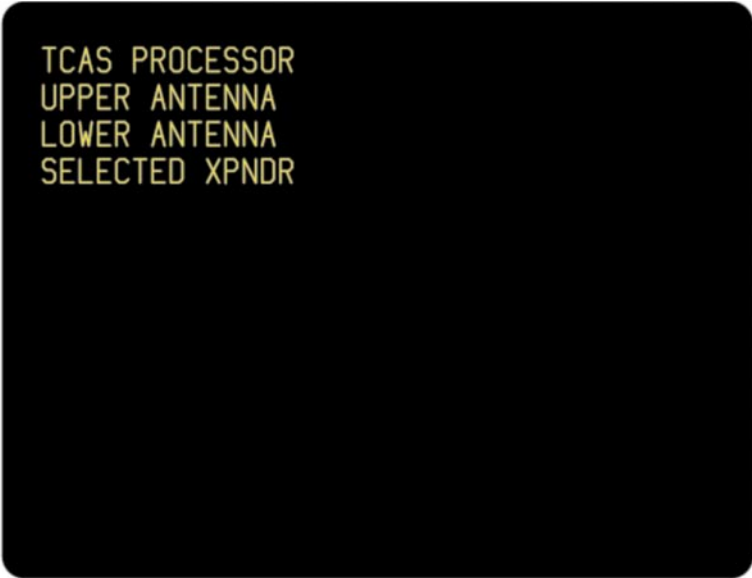

TCAS PROCESSOR
UPPER ANTENNA
LOWER ANTENNA
SELECTED XPNDR

ITA 81A DEDICATED TCAS TRAFFIC DISPLAY

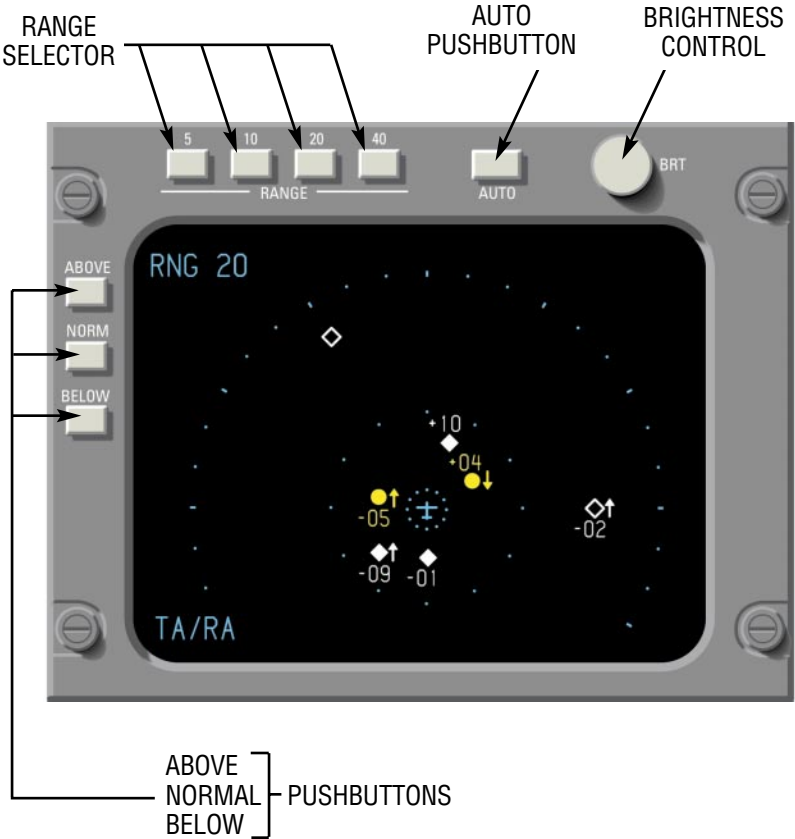

ITA 81A DEDICATED TCAS TRAFFIC DISPLAY CONTROLS

5 10 20 40 Pushbutton Range Selectors select range to be displayed.



 AUTO

AUTO Pushbutton: At Power-Up the screen initially displays all TCAS traffic. Pressing the button alternates between Full-Time and TCAS Pop-Up modes.

When in Pop-Up mode, the screen clears and remains blank until TA or RA traffic appears. Then all TCAS traffic is displayed. TCAS AUTO is annunciated. The screen automatically clears when there are no more TAs or RAs to be displayed. Pressing the TCAS/AUTO button when no TCAS traffic is displayed returns the display to the Full-Time display mode.

ABOVE

 NORM

 BELOW

Pushbutton controls select vertical display limits (Above/Norm/Below). There are three display levels to choose from.

ABOVE(Climb phase) 8700 feet above (9000 Change 7 or later); 2700 feet below.

NORMAL (Enroute phase) 2700 feet above; 2700 feet below.

BELOW (Descent phase) 2700 feet above; 8700 feet below (9000 Change 7 or later).

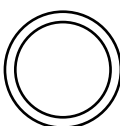
 BRT

Adjusts display brightness

IVA 81B & KAV 485T RA/VSI RESOLUTION ADVISORY/VERTICAL SPEED INDICATOR

Two rows of colored lights, one red and one green, are located around the vertical speed scale. The RA/VSI indicates whether to climb, descend, or maintain vertical speed by illuminating segments of these rows. The required vertical maneuver keeps the pointer out of the red, and/or into the green areas.



IVA 81B

IVA 81B

The flag above the vertical speed pointer indicates vertical speed has failed (Amber with Black Text).

The flag below the vertical speed pointer indicates TCAS status. (1) TCAS (Amber with Black Text). (2) RA OFF (White with Black Text). (3) TCAS Valid (All Black).



KAV 485T

KAV 485T

The flag on the left of the vertical speed pointer indicates vertical speed has failed (Red with Black Text).

The flag on the right of the vertical speed pointer indicates TCAS status. (1) TCAS (Amber with Black Text). (2) RA OFF (White with Black Text). (3) TCAS Valid (All Black).

IVA 81A/C/D TA/VSI TRAFFIC ADVISORY/VERTICAL SPEED INDICATOR

The TA/VSI combines the vertical speed instrument with the TA and RA display functions. Red and green bands around the circumference of the screen give RA information. Traffic location is presented on the face of the display inside of the vertical speed scale.

The TA Select Pushbutton can be wired for either a Traffic Select or Switchable configuration at time of installation.

In both configurations, when a TA or RA is present all traffic Pop-up on the display. Pressing the button alternates between showing all traffic and VSI display only.

When the display is clear of traffic, presence of a new TA or RA intruder Pop-up all traffic on the display. Without traffic the instrument operates as a VSI only.

Note: For all NVIS types, when the NVIS mode is selected, the pointer, border, numerals and the scale graduations which are normally white will be green.

CONFIGURATION	
SWITCHABLE	TRAFFIC SELECT
The traffic clears only by pressing the button.	The traffic clears either by pressing the button or as a result of threat no longer present.
After a TA or RA clears, the display of traffic remains.	Pressing the button has no effect when no TA or RA traffic is present. Traffic is not shown unless a threat occurs. Unit automatically returns to Pop-up mode when threat is no longer present.

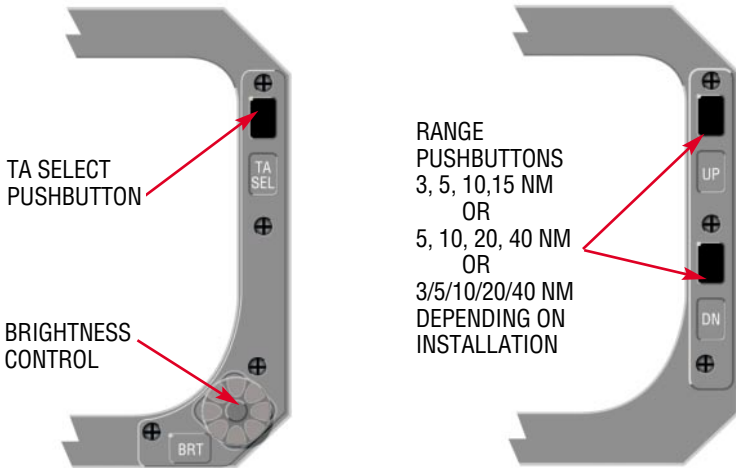

DISPLAY MESSAGE LOCATIONS

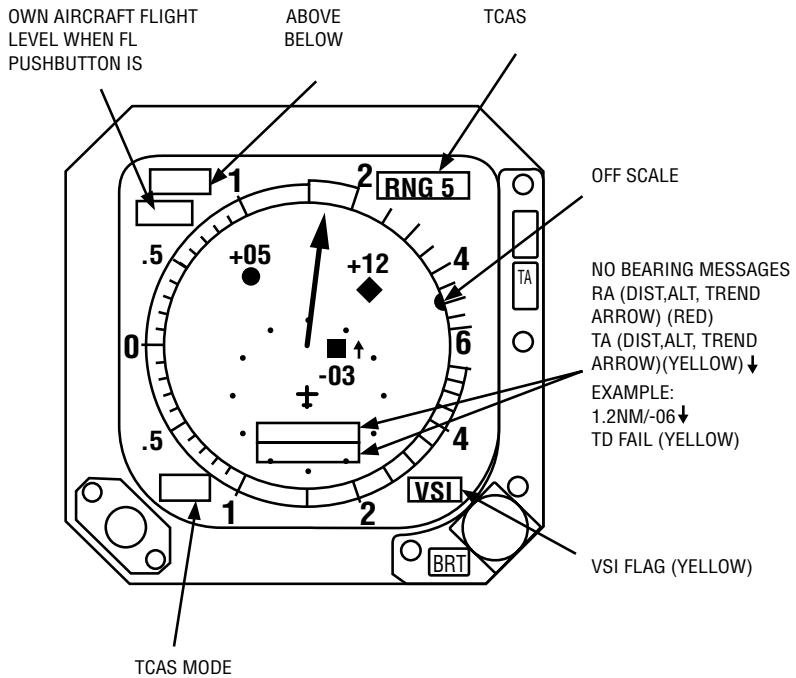

TCAS MODE/FAILURE

Standard	Optional	Indicates
TCAS STBY (Blue)	NO TCAS (Blue)	TCAS system in standby
TA/RA (Blue)		Normal Operation
TEST (Yellow)	TEST (Yellow)	Self-Test
TA ONLY (Blue)	TA ONLY (Blue/Yellow)	When active TA
TCAS (Yellow)	NO TCAS (Yellow)	TCAS system failure

TYPICAL TA/VS1 SCENARIOS



CLIMB,...



MONITOR VERTICAL SPEED,...



MONITOR VERTICAL SPEED,...



TRAFFIC,...



MONITOR VERTICAL SPEED,...



DESCEND,...

SECTION III: SYSTEM CONSIDERATIONS

SECTION III EXPLAINS CONSIDERATIONS OF THE SYSTEM; WARNINGS AND LIMITATION, CAUTIONS AND NOTES.

WARNINGS AND LIMITATIONS

The capability of TCAS II is dependent upon the type of transponder in the intruding aircraft:

- The intruding aircraft must be equipped with a properly operating transponder for normal TCAS operation. TCAS is unable to detect any aircraft without an operating transponder.
- If the intruder is Non-Altitude Reporting (NAR), TCAS will display only the range and bearing. It can issue a Traffic advisory based on distance and direction of flight but will not generate a Resolution Advisory. TCAS assumes Non-Altitude Reporting (NAR) traffic is at the same altitude as your own aircraft.

A TCAS II Resolution Advisory is based on the expectation that the crew will comply within 5 seconds. An increase or reversal to an RA requires two and one half seconds reaction time.

The TCAS II processor is programmed with the specific aircraft operating limitations, i.e., maximum altitude at which the aircraft can climb at 1500 feet per minute. Climb or Increase Climb RAs are therefore inhibited when the RA maneuver cannot be completed safely due to lack of aircraft performance capability. These performance limits are included as part of the aircraft wiring. See the AFM for the specific performance limitations for your aircraft.

Wiring options for TCAS also include the following:

- TCAS can be wired to display all traffic full time or all traffic only as a result of the presence of a TA or an RA (Pop-Up Mode).
- Number of targets displayed from (3 to 30)
- The TCAS display may have pilot selectable range or may be a fixed range controlled by the aircraft wiring.
- The IVA 81A/C/D can be wired to clear the display automatically after a TA or RA passes or by pressing the TA SEL button.
- The TCAS II system can be automatically placed in standby when the aircraft is on the ground.
- The manually initiated system test procedure can be inhibited in flight.
- The aircraft Master Lamp Test Switch can be wired to control the TA/VSI and RA/VSI sequential lamp test.

WARNINGS AND LIMITATIONS (CONT'D)

- TCAS can be wired to inhibit display of traffic on the ground when your own aircraft is below 1700 ±50' AGL. If configured this way, aircraft on the ground disappear as you descend through 1650' and reappear on the traffic display as you climb above 1750'. TCAS II designates "On-Ground" traffic by comparing own aircraft radio altitude and pressure altitude. Any intruder estimated by TCAS to be within 380 feet of the ground descending or 400 feet ascending will be categorized as "On-Ground."

If not configured this way, all On-Ground intruders are displayed as non-threat traffic (open white diamond).

- Increase Descent Resolution Advisories are inhibited below 1450 feet AGL.
- All Resolution Advisories are inhibited below 900 feet descending or 1100 feet ascending.
- All TCAS II audio warnings are inhibited below 900 feet Radio Altitude on approach and up to 1100 feet Radio Altitude on departure.

CAUTIONS

Always attempt to visually clear the airspace before maneuvering your aircraft in response to a TCAS advisory.

The TCAS installation can be wired to give GPWS and Wind Shear higher priority than TCAS. In case of simultaneous audio alarms, the TCAS II system is placed in TA ONLY mode and the RA/VSI flag will show the RA OFF.

NOTES

Refer to the Airplane Flight Manual for the specific operational features of the TCAS installation.

When TCAS commands a corrective Resolution Advisory, sufficient time exists to perform a smooth vertical maneuver to avoid the conflict. TCAS II expects five second crew reaction time to RAs, requiring approximately .25 G. An increase or reversal to an RA requires two and one half seconds reaction time and up to .35 G.

It is possible to see an aircraft flying the same course and direction as your own aircraft, yet TCAS II may not consider it a threat. TCAS II calculates the closure rate of the intruder, and derives the time to the closest point of approach (CPA). If there is no closure rate, no advisory will be issued, unless the intruder is very close (within approximately 1/4 mile). Conversely, traffic at the same altitude very far ahead may be shown as an RA by TCAS because of a very rapid closure rate.

SECTION IV: APPENDIX

THE APPENDIX INCLUDES THE TEST FUNCTION OF TCAS II EQUIPMENT, A GLOSSARY OF TCAS TERMS AND RECOMMENDATIONS FOR POST FLIGHT REPORTS.

Intentionally left blank

FUNCTIONAL AND AUTOMATIC SELF TEST

The Mode S transponder and TCAS Functional Test determines the operational status of the entire system. The test is initiated by rotating the function selector knob on the Transponder Control Panel to the TEST position.

Thereafter, the test continues automatically for a period of approximately eight seconds. During the test the TCAS II and transponder function is inhibited. When the knob is held for longer than eight seconds the system remains in test until it is released.

If the weather radar indicator is OFF, warm up time for the weather radar indicators is about 5 seconds.

During the first few seconds of the test sequence, the radar indicator and the TA/VSI allow verification of each type of intruder symbol. The test generates the symbols arranged as shown. The Traffic Advisory Display annunciates the word TEST. If the weather radar is in the TEST function, this pattern appears over the PPI test pattern. If in a weather function, this test appears over weather.

Use of the self test function in flight will inhibit TCAS II for up to 8 seconds. For this reason, the pilot should use caution when initiating the test in flight. Depending upon the installation, self test in flight may be inhibited.



CAS 67A Radar Test Pattern;
5NM range



CAS 67A TA/VS/TEST
Pattern; 5NM range

A Resolution Advisory (red square) will appear at 3 o'clock, range of 2 miles, 200 feet above and flying level.

A Traffic Advisory (yellow circle) will appear at 9 o'clock, range of 2 miles, 200 feet below and climbing.

Proximity traffic (solid white diamond) will appear at 1 o'clock, range 3.6 miles, 1000 feet below descending.

Non-Threat traffic (open white diamond) will appear at 11 o'clock, range of 3.6 miles, flying level 1000 feet above.

RA/VS/TEST FLAGS AND TEST INDICATIONS

During the first few seconds of the TEST, the RA/VS red and green circumference lights (the climb/descend indicators) illuminate sequentially. The TCAS flag is in view throughout the test period.



Sequential Lamp Test

Note: KAV 485T TCAS test indications are the same as the IVA 81B.

After the sequential lamp test, the red and green climb/descend lights display a fixed test command throughout the remainder of the system test.



Fixed Test Command

At the conclusion of a successful Self-Test, a synthesized voice announces:

“TCAS SYSTEM TEST OK”

RA/VSI AND TA/VSI LAMP TESTS

RA/VSI Lamp Tests

If the aircraft wiring includes a lamp test function, the RA/VSI sequential lamp test can be observed by activating the Master Lamp Test Switch. The test will continue as long as the switch is held in the test position.

TA/VSI Lamp Test

The TA/VSI lamp test produces an array of traffic in the pattern shown. The climb/descend color bands alternate between green and red, lasting for two seconds each. The bands are blank for a one second interval in between.

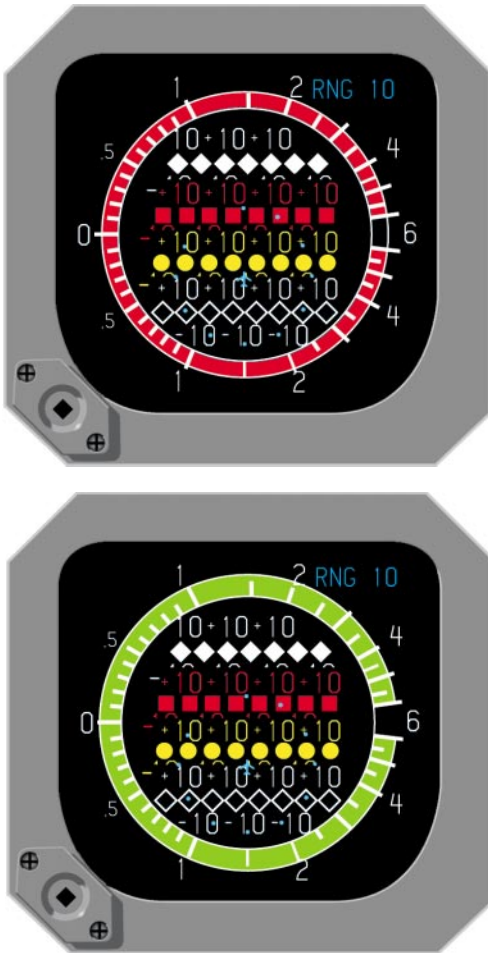

Note: The VSI function of the TA/VSI will not be observed during the lamp test.

FAILURE CONDITIONS

Should a VSI failure be detected at any time, the VSI flag will appear.

Should a failure be detected during Self Test, the audio message says:

“TCAS SYSTEM TEST FAIL”

If the TA display is a Radar Indicator or dedicated display, the appropriate failure message will be displayed. (See Fault Message Format in Section II: Controls and Displays.)

TEST AUDIO INHIBIT

TCAS test audio is inhibited during GPWS and windshear test or alert.

CTA 81B CLOCKWISE TEST POSITION

The CTA 81B function selector is moved to the right hand test position (switch fully clockwise) to test the ATCRBS transponder. During the test, segments of the Transponder Control Unit display window and the ATC Fail lamp illuminate.

POST FLIGHT REPORTS

If a failure of the TCAS system has occurred, give Maintenance as much specific information about the problem as possible. Avoid phrases such as “TCAS inop.”

Provide information in terms of fault lights lit, audio announcements, test pattern discrepancies and screen annunciations that indicate which unit was observed to have failed.

GLOSSARY OF TCAS TERMS

ABBREVIATIONS AND DEFINITIONS

AFMS	Airplane Flight Manual Supplement
AGL	Above Ground Level
ATC	Air Traffic Control. A federally operated ground based system that manages aircraft traffic flow.
ATCRBS	ATC Radar Beacon System. A ground based secondary radar and airborne transponder system used to monitor traffic.
Absolute Altitude	Altitude above Mean Sea Level (MSL). See Pressure Altitude.
Altitude Tag	Data tag shown above or below threat symbol giving the relative altitude or the flight level of the intruder.
BITE	Built-In Test Equipment. A feature of TCAS that continuously monitors itself for operational errors.
CPA	Closest Point of Approach. Refers to predicted point at which the intruder will be closest to your own aircraft.
Crossover Climb, Crossover Descent	The maneuver that TCAS has determined to be appropriate is a climb or descent through the altitude of the threat aircraft. The crew is alerted to the crossover maneuver by an audio message.
FID	Flight Identification

ABBREVIATIONS AND DEFINITIONS (CONT'D)

G-force	The ratio between a given load and the pull of gravity. <i>For TCAS purposes, G-forces of an RA could reach $\pm.25$ above/below 1 G and increase to approximately $\pm.35$ G during an increase or reversal of the original command.</i>
IDENT	SPI pulse added to Mode A replies as method for ground to identify transponder.
Increase Maneuver	An increase maneuver is a change of the original Resolution Advisory command, either climb or descent, requiring a greater rate. The increase maneuver could require G-forces to reach approximately $\pm.35$ within 2.5 seconds.
Indicated Altitude	Altitude shown on the altimeter with barometric correction setting set to local sea level pressure. Used by the crew below 18,000 feet but not used for TCAS processing.
Intruder	Any aircraft that is in the surveillance range of TCAS.
LRU	Line Replaceable Unit. A self-contained avionics component that can be replaced in the field.
Mode A Transponder	ATCRBS transponder that replies to ATC interrogations sending identification code but without giving altitude data.
Mode C Transponder	ATCRBS transponder that replies to ATC interrogations giving identification code or encoded altitude data.
Mode S Transponder	Transponder that replies to ATC interrogations giving an ATCRBS identification code, encoded altitude and other data fields including aircraft discrete address.

ABBREVIATIONS AND DEFINITIONS (CONT'D)

NAR	Non-Altitude Reporting traffic.
Non-Threat Intruder	An aircraft that has entered the TCAS surveillance volume at a distance greater than 6 miles or altitude greater than 1200 feet above or below your own aircraft.
Pressure Altitude	Indicated altitude when barometric pressure is set to 29.92" Hg. (1013mb). Pressure altitude is used by TCAS to determine the relative altitude of traffic.
Proximity Intruder	An aircraft that is within 6 miles range and within 1200 feet above or below your own aircraft but does not meet the TCAS definition of a threat.
Rad Alt	Radio Altitude. Altitude received from a radio altimeter and used by TCAS to determine distance to the surface.
RA	Resolution Advisory. An audio and visual indication recommending a vertical maneuver to achieve separation from an intruding aircraft. RAs are made up of preventive and corrective maneuvers described in this manual.
RA/VSI	Resolution Advisory/Vertical Speed Indicator. A flight instrument that gives standard VSI indication plus RA climb and descend requirements.
Relative Altitude	The difference in altitude between two aircraft. TCAS calculates relative altitude as the difference between your own aircraft's pressure altitude and the encoded pressure altitude of the intruder.

ABBREVIATIONS AND DEFINITIONS (CONT'D)

Reversal Maneuver	A reversal maneuver is a change of the original Resolution Advisory command from a climb to a descent or vice versa. The reversal maneuver could require G-forces to reach approximately $\pm.35$ within 2.5 seconds.
Self Test	A functional test that determines equipment status. Self test differs from BITE performance monitoring because it is initiated by the crew and is not performed continually or automatically.
Surveillance Volume	The volume of airspace surrounding your aircraft that TCAS scans for intruding traffic. The TCAS system scans approximately 40 NM in front of and 9000 feet above and below the aircraft. The volume will automatically begin to decrease when flying into a high density area and may be reduced to approximately 15 NM in front of the aircraft.
TA	Traffic Advisory. An audio and visual indication that another aircraft is a potential threat. A TA may become a Resolution Advisory within 15 seconds.
TA/VS	Traffic Advisory/Vertical Speed Indicator. A flight instrument that gives standard VSI indication, plan position of local traffic, plus RA climb and descend requirements.
Threat	An aircraft that has satisfied TCAS threat detection logic and thus requiring a Resolution Advisory.

Intentionally left blank

Honeywell International Inc.
One Technology Center
23500 West 105th Street
Olathe, Kansas 66061
FAX 913-791-1302
Telephone: (913) 712-0400

Copyright ©1999, 2004 Honeywell International Inc.
All rights reserved.

006-08499-0000
Rev 7 2/04

Honeywell