



TI5200 GPU-24-PFC

Power Anytime, Anywhere



Benefits

- Ideal for small to medium size, fixed wing aircraft
- Perfect for testing and troubleshooting (avionics, TMDE, electronics, and hydraulics)
- System back-charges from the started vehicles' engine in minutes
- <1% THD (Total Harmonic Distortion)
- 99.95% active power factor correction
- Will charge and maintain vehicle batteries when unit is left connected to vehicle (ac power required)
- Safe, easy, maintenance-free operation

Safe and Easy Operation

- One person can maneuver and operate the unit
- Safe for flight, non-hazardous, dry-cell technology
- "Push to Test" feature provides instant state of charge

Pure Power

- No spikes or surges
- 3000 peak starting amps
- 200 amps continuous @ 28.5 Vdc (when plugged into ac power)
- 46 amp hours (1024 watt hours) of rechargeable battery power without ac
- 246 amp hours (6724 watt hours) with ac power
- Operates and charges from single phase 200-260 Vac power 40 Hz - 450 Hz

INCLUDES



TI25000-058 (CS8265) 25ft. Hardwired
Single Phase Plug AC Line Cord

and



TI2007-208
8ft. DC Aviation Cable Assembly

or



TI2007-315
15ft. DC NATO Cable Assembly

Tesla™ Industries, Inc.

www.teslainsd.com

Email: tesla1@teslainsd.com

Headquarters: (302) 324-8910

101 Centerpoint Blvd. New Castle, DE 19720 USA

Western Regional Office: (775) 622-8801

9475 Double R Blvd. Suite 2, Reno, NV 89521 USA



**The POWER
Of
RED™**



Dimensions and Technical Specifications

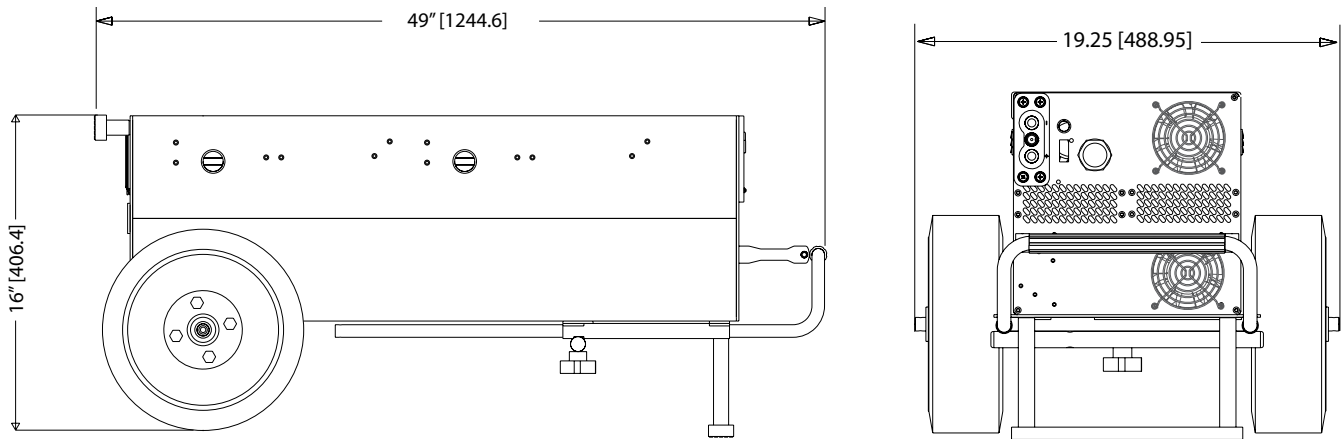

* All dimensions are in inches [millimeters]

Technical Specifications:

DC Output	46 amp hours (1024 watts) of rechargeable power without ac power 246 amp hours (6724 watts) with ac power 200 amps continuous @ 28.5 Vdc (plugged into ac power)
Peak Starting Amps	3000 A
AC Input	Operates and charges from Single Phase 200-260 Vac / 40 Hz - 450 Hz 33.5 amps @ 208 Vac 60 Hz Requires 50 amp service (contact Tesla for receptacle information)
Recharging Rate	19 minutes (from full discharge) @ 25 °C
Vibration	Exceeds MIL-STD-810F
Storage Temperature	-65 °C to 105 °C (-85 °F to 221 °F)
Operating Temperature w/o AC Power	-40 °C to 60 °C (-40 °F to 140 °F)
Operating Temperature w/ AC Power	-40 °C to 55 °C (-40 °F to 131 °F)
Weight	177 lbs (80.28 kg)

Optional Accessories:



TI7000-104 Protective Cover



TI7000-175 Shipping Case



Power Anytime, Anywhere

Tesla™ TI5200 GPU-24-PFC

User Manual



Built Smart...Proven Tough

Tesla Industries, Inc.
101 Centerpoint Blvd.
New Castle, DE 19720
(302) 324-8910 Phone
(302) 324-8912 Fax
www.teslainsd.com

**NOTE: All users must read this entire manual prior
to operating the TI5200 GPU-24-PFC-PFC.**

The TI5200 GPU-24-PFC-PFC is a limited maintenance-free and sealed unit. No repairs are authorized. Warranty will be voided if unit is tampered with in any way, or if unauthorized repairs are made. For technical support please contact:

TESLA™ INDUSTRIES INCORPORATED

101 CENTERPOINT BLVD.
CENTERPOINT INDUSTRIAL PARK
NEW CASTLE, DELAWARE 19720

PHONE: (302) 324-8910

FAX: (302) 324-8912

WEBSITE: www.teslaind.com

EMAIL: tesla1@teslaind.com



CAUTION

Shock Hazard Potential

Improper use or failure to follow instructions in this user manual can result in unit damage and/or injury or death by electrical shock.

Any attempts to open or examine the inside of the TI5200 GPU-24-PFC-PFC via a tool or device (borescope, probe, etc.) can result in unit failure and/or injury by electrical shock. This GPU is maintenance free and should not be opened or disassembled for any reason.

Always protect the unit from short circuit.

Shipping Hazards: The TI5200 GPU-24-PFC-PFC contains sealed, dry cell rechargeable batteries that do not pose a shipping hazard.

No part of this manual may be reproduced or transmitted in any form or by any means, electronic or mechanical, including photocopying, recording, or any information storage and retrieval system, without prior written permission from Tesla™ Industries, Inc.

Copyright © 2014 by Tesla™ Industries, Incorporated. All rights reserved.



INFORMATION ONLY - PLEASE READ SECTION X

SECTION I - PRODUCT AND MANUFACTURER IDENTITY

Product Identity:

Tesla[®]™ Turbo Start[®]™ Ground Power Unit (GPU) and Micro Power Unit (MPU) Containing Dry Cell (Starved Electrolyte) Batteries Used on Aviation/Military Application

Manufacturer's Name and Address:

Tesla Industries Inc.
101 Centerpoint Blvd.
New Castle, Delaware 19720

Emergency Telephone Number:

(302)324-8910
Fax: (302)324-8912
www.Teslainsd.com

SECTION II - INGREDIENTS

Hazardous Components	CAS #	OSHA PEL-TWA	% (By weight)
Lead	7439-92-1	50 µg/m ³	45 - 60 %
Lead Dioxide	1309-60-0	50 µg/m ³	15 - 25%
Sulfuric Acid Electrolyte	7664-93-9	1.0 mg/m ³	15 - 20%
Non-Hazardous Materials	N/A	N/A	5 - 10%

SECTION III - PHYSICAL/CHEMICAL CHARACTERISTICS

Boiling Point - N/A

Specific Gravity (H₂O=1) - NA

Vapor Pressure (mm Hg.) - N/A

Melting Point - N/A

Solubility in Water - N/A

Appearance & Color - N/A

SECTION IV - FIRE & EXPLOSION HAZARD DATA

Flash Point (Method Used): N/A

Flammable Limits: N/A

LEL: N/A

UEL: N/A

Extinguishing Media: Multipurpose Dry chemical CO₂ or water spray.

Special Fire Fighting Procedures: Cool GPU/MPU exterior to prevent rupture. Acid mists and vapors in a fire are toxic and corrosive.

Unusual Fire and Explosion Hazards: Hydrogen gas may be produced and may explode if ignited. Remove all sources of ignition.

SECTION V - REACTIVITY DATA AND SHIPPING/HANDLING ELECTRICAL SAFETY

Stability: Stable

Conditions to Avoid: Avoid shorting, high levels of short circuit current can be developed across the battery terminals. Do not rest tools or cables on the battery. Avoid over-charging. Use only approved charging methods. Do not charge in gas tight containers.

SECTION VI - HEALTH HAZARD DATA

Routes of Entry: N/A

Health Hazards (Acute & Chronic): N/A

Emergency & First Aid Procedures:

Battery contains acid electrolyte, which is absorbed in the separator material. If battery case is punctured, completely flush any released material from skin or eyes with water.

Proposition 65:

Warning: Battery posts, terminals and related accessories contain lead and lead compounds, chemicals known to the State of California to cause cancer and reproductive harm. Batteries also contain other chemical known to the State of California to cause cancer. Wash hands after handling

SECTION VII - PRECAUTIONS FOR SAFE HANDLING & USE

Steps to be taken in case material is released or spilled

Avoid contact with acid materials. Use soda ash or lime to neutralize. Flush with water.

Waste Disposal Method

Dispose of in accordance with Federal, State, & Local Regulations. Do not incinerate. Batteries should be shipped to a reclamation facility for recovery of the metal and plastic components as the proper method of waste management. Contact distributor for appropriate product return procedures.

SECTION VIII - CONTROL MEASURES - NOT APPLICABLE

SECTION IX - OTHER REGULATORY INFORMATION

Tesla™ Industries GPU/MPU batteries are sealed electrolyte batteries, which means the electrolyte is absorbed in the separator material. The batteries are also sealed.

NFPA Hazard Rating for Sulfuric Acid:

Health (Blue) = 3

Flammability (Red) = 0

Reactivity (Yellow) = 2

Sulfuric Acid is Water Reactive if concentrated.

U.S. DOT: Tesla™ Industries GPU/MPU batteries are classified as Nonspillable. They have been tested and meet the nonspillable criteria listed in 49 CFR § 173.159(f) and 173.159a(d)(1).

Nonspillable batteries are excepted from 49 CFR Subchapter C requirements, provided that the following criteria are met:

1. The batteries must be securely packed in strong outer packagings and meet the requirements of 49 CFR § 173.159a.
2. The batteries' terminals must be protected against short circuit.
3. Each battery and their out packaging must be plainly and durably marked "NONSPILLABLE" or "NONSPILLABLE BATTERY".

The exception from 49 CFR, Subchapter C means shipping papers need not show proper shipping name, hazard class, UN number and packing group. Hazardous labels are not required when transporting a nonspillable battery.

IATA: Tesla™ Industries GPU/MPU batteries have been tested and meet the nonspillable criteria listed in IATA Packing Instruction 872 and Special Provision A67. Nonspillable batteries must be packed according to IATA Packing Instructions 872. This means shipping papers need not show proper shipping name, hazard class, UN number and packing group. Hazardous labels are not required when transporting a nonspillable battery.

These batteries are excepted from all IATA regulations provided that the batteries are packed in a suitable out packaging and their terminals are protected against short circuits.

IMDG: Tesla™ Industries GPU/MPU batteries have been tested and meet the nonspillable criteria listed in Special Provision 238. Non-spillable batteries must be packed according to IMDG Packing Instruction P003. This means shipping papers need not show proper shipping name, hazard class, UN number and packing group. Hazardous labels are not required when transporting a nonspillable battery. These batteries are excepted from all IMDG codes provided that the batteries are packed in a suitable out packaging and their terminals are protected against short circuits per PP16.

RCRA: Spent lead-acid batteries are not regulated as hazardous waste by the EPA when recycled, however state and international regulations may vary.

CERCLA (Superfund) and EPCRA:

- (a) Reportable Quantity (RQ) for spilled 100% sulfuric acid under CERCLA (Superfund) and EPCRA (Emergency Planning Community Right to Know Act) is 1,000 lbs. State and local reportable quantities for spilled sulfuric acid may vary.
- (b) Sulfuric acid is a listed "Extremely Hazardous Substance" under EPCRA, with a Threshold Planning Quantity (TPQ) of 1,000 lbs.
- (c) EPCRA Section 302 notification is required if 1,000 lbs. or more of sulfuric acid is present at one site.
- (d) EPCRA Section 312 Tier 2 reporting is required for batteries if sulfuric acid is present in quantities of 500 lbs. or more and/or if lead is present in quantities of 10,000 lbs. or more.
- (e) Supplier Notification: this product contains toxic chemicals, which may be reportable under EPCRA Section 313 Toxic Chemical Release inventory (Form R) requirements.

If you are a manufacturing facility under SIC codes 20 through 39, the following information is provided to enable you to complete the required reports:

<u>Toxic Chemicals</u>	<u>CAS Number</u>	<u>Approximate % by Wt.</u>
Lead	7439-92-1	45-60
Sulfuric Acid	7664-93-9	15-20

SECTION X - ADDITIONAL INFORMATION

The Tesla™ Industries GPU/MPU sealed lead acid battery is determined to be an "article" according to the OSHA Hazard Communication Standard and is thereby excluded from any requirements of the standard. The Material Safety Data Sheet is therefore supplied for informational purposes only.

The information and recommendations contained herein have been compiled from sources believed to be reliable and represent current opinion on the subject. No warranty, guarantee, or representation is made by Tesla™ Industries, as to the absolute correctness or sufficiency of any representation contained herein and Tesla™ Industries assumes no responsibility in connection therewith, nor can it be assumed that all acceptable safety measures are contained herein, or that additional measures may not be required under particular or exceptional conditions or circumstances.

*N/A or Not Applicable - Not applicable for finished product used in normal conditions.

Table of Contents

Section 1 – Safety Review	1
1.1 – Safety Notices	1
1.2 – Symbols	1
1.3 – Hazards	2
1.4 – Important Safety Precautions	2
1.5 – Extreme Environments	2
Section 2 – Product Overview	3
2.1 – Introduction	3
2.2 – Indication of Terms: Shall, Should, and May	3
2.3 – Front Panel Overview	4
2.4 – General Specifications	5
2.5 – Physical Dimensions	6
2.6 – Airflow Ports	6
2.7 – Operating Positions	7
2.8 – “Push to Test” Button and LED Status Indicator	8
2.9 – Active Power Factor Correction	9
2.10 – AC Input Circuit Breaker	10
2.11 – AC Line Cord	10
2.12 – 24 Vdc Output Connector	11
2.13 – Interface Connector	11
Section 3 – Operating Procedures	12
3.1 – Operating Procedures	12
3.2 – General	12
3.3 – Operating Limits and Restrictions	12
3.4 – Performance	12
3.5 – Engine Starting Power	12
3.6 – Temperature Specifications	13
3.7 – Environmental	14
3.8 – Normal Functional Test Procedures	15-16
3.9 – Pre-Operation	17
3.10 – Transporting Unit	17
3.11 – Regulated 28.5 Vdc Ground Power	18-19
3.12 – Operating with a Digital Volt/Amp Meter	19
3.13 – Regulated AC Power	20
3.14 – Charging Unit	21
3.15 – Circuit Breaker Switch	21

Section 4 – Post Operation	22
4.1 – General	22
4.2 – After Use	22
4.3 – Power Cell Recharge	22-23
Section 5 – Unit Care and Maintenance	24
5.1 – Unit Care	24
5.2 – Unit Servicing	25
5.3 – Packaging and Shipping	25
5.4 – Storage	25
Section 6 – Troubleshooting and FAQ	26
6.1 – Frequently Asked Questions	26-27
6.2 – Basic Usage/Operation Questions	28
6.3 – Basic Troubleshooting	29-30
Section 7 – Performance Data	30
7.1 – Purpose	30
7.2 – General	30
7.3 – Data Basis	30
7.4 – Specific Conditions	30
7.5 – General Conditions	30
7.6 – Temperature Conversion Chart	30
7.7 – Output Voltage	33
7.8 – Maximum Output Current	33
Section 8 – Optional Accessories	34
8.1 – Shipping Case	34
8.2 – GPU Protective Covers	34
8.3 – Digital Volt/Amp Meter(TI3100A)	34
8.4 – GPU Tires	34
8.5 – Cobra™ DC Replacement Contacts and Tools	35
Repair Request Form	37

Abbreviations and Symbols

Abbreviations that may be used within the text, headings and titles of this manual.

LIST OF ABBREVIATIONS



Abbreviation **Definition**

ac	Alternating Current
AFT	Airflow Technology
AWG	American Wire Gauge
amp or A	Ampere
cont	Continuous
°C	Degree Celsius
°F	Degree Fahrenheit
dc	Direct Current
EFF	Efficiency
ft	Feet
FWD	Forward
GPU	Ground Power Unit
Hr	Hour
Hz	Hertz
kg	Kilograms
kHz	Kilohertz
kW	Kilowatts
LED	Light Emitting Diode
max	Maximum
MΩ	megaohm
min	Minimum
MPU	Micro Power Unit
NEMA	National Electrical Manufacturers Association
Ω	ohm
PF	power factor
PFC	power factor correction
rms	root-mean-square
THD	Total Harmonic Distortion
TMDE	Test, Measurement, & Diagnostic Equipment
UAV	Unmanned aerial vehicle
Vac	Volts, Alternating Current
Vdc	Volts, Direct Current
W	watts

Section 1 – Safety Review

1.1 - Safety Notices

Safety notices appear throughout this manual to alert the user to important information regarding proper installation, operation, maintenance and storage of the unit. These notices, as illustrated below, contain a key word that indicates the level of hazard and a triangular icon that indicates the specific type of hazard.

 WARNING	Indicates a condition, operating procedure or practice, which if not adhered to could result in serious injury or death.
 CAUTION	Indicates a condition or operating procedure, which if not strictly adhered to could result in damage or destruction of equipment.
 NOTE	Indicates a condition, operating procedure or practice, which is essential to highlight.

1.2 - Symbols

The following symbols will appear within the warning triangles to alert the user to the specific type of danger or hazard.



Figure 1.2.1 – Different types of hazard and caution symbols

1.3 – Hazards



WARNING

Shock Hazard Potential

Severe injury or death from electrical shock will occur if either the user or the unit is wet while operating the unit with the 200-260 Vac power source attached. Be sure to disconnect ac power from the ac source if the unit has come into contact with water. If the AC Input Circuit Breaker has tripped due to water infiltration, DO NOT try to reset circuit breaker until GPU has dried completely.



WARNING

Shock Hazard Potential

Severe injury or death from electrical shock can occur when damp electrical plugs are connected to the unit. Make sure the electrical outlet is switched off before making any connections. Failure to use proper grounding can cause potential shock hazard!

CAUTION

Unit Damage Potential

The unit will be damaged if unapproved ac power is applied. This Unit operates from Single Phase 200-260 Vac, 40 Hz - 450 Hz. This must match ac power source (hangar wall, flight line ac power) prior to connecting the unit.

1.4 – Important Safety Precautions



WARNING

Fire/Explosion Hazard Potential

Severe injury or death from fire or explosion can occur if electrical sparks are produced near fuel vapors. Power output is 28.5 Vdc. DO NOT CONNECT ac power to GPU while operating or handling any aircraft fuel.

1.5 – Extreme Environments



CAUTION

Unit Damage Potential

The unit is equipped with a charger temperature switch that automatically disables ac and charging functions when the internal temperature reaches above 150°F (65°C). This protects the unit from overheating and damage. If the unit shuts down, move the unit into a cooler climate such as shade or air conditioning when possible. Perform a full function test prior to use after the unit has been allowed to cool.

Section 2 – Product Overview

2.1 – Introduction

This manual contains the complete operating instructions and procedures for the TI5200 GPU-24-PFC ground power unit. The TI5200 GPU-24-PFC is intended to provide dc electrical ground power for aircraft flight line and maintenance ground support operations. The unit is designed to provide 24 Vdc electrical power output for aircraft engine starting and 24 or 28.5 Vdc electrical support for ground maintenance, avionics/ electrical trouble shooting and testing. The observance of procedures, limitations and performance criteria is essential to ensure peak operating efficiency and to maximize operational capabilities and life of the TI5200 GPU-24-PFC.

This GPU is one of Tesla™ Industries latest advancements in power technology development. This GPU features a 6.5kW active Power Factor Correction (PFC) that is capable of pulling a current waveform identical to the applied voltage waveform. This is the only PFC on the market that is capable of operating at 40 Hz to 450 Hz with 1% THD (Total Harmonic Distortion).

What this means for the end user is that this GPU is capable of producing the same output power of one of our three phase GPU's while operating off of single phase power. It offers a wide versatility of power options while effectively lowering energy consumption.

The TI5200 GPU-24-PFC was designed to provide 200 amps @ 28.5 Volts of pure regulated flat line dc power for vehicle ground support, avionics, battery charging, power for training facility operations, and for all 24 Volt systems.

This manual contains the complete operating instructions and procedures for the TI5200 GPU-24-PFC that the end user will need to safely and efficiently operate this GPU.

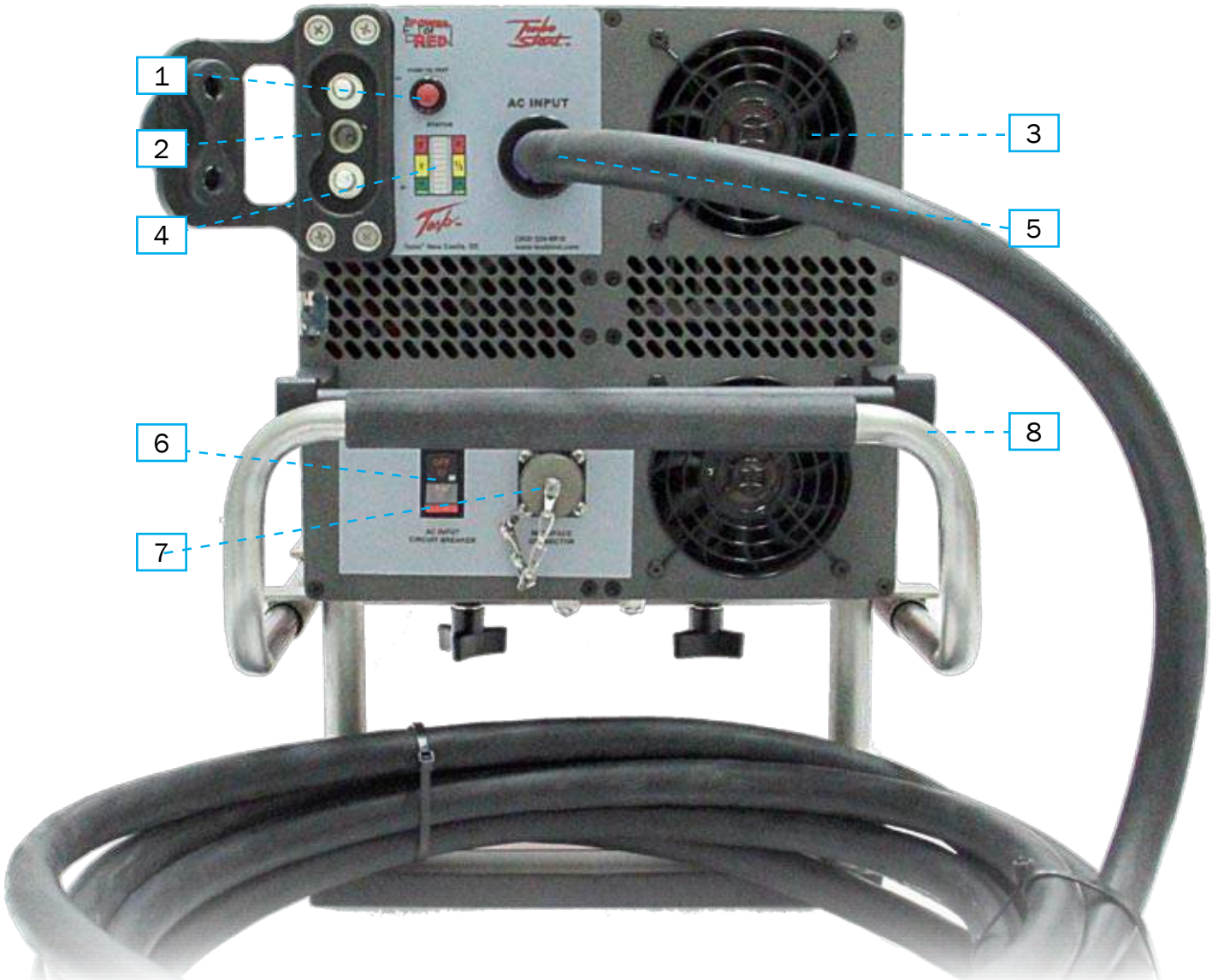

Figure 2.1.1 – TI5200 GPU-24-PFC

2.2 – Indication of Terms: Shall, Should and May

Within this technical manual the word “shall” is used to indicate a mandatory requirement for proper operation and warranty purposes. The word “should” is used to indicate a non-mandatory but preferred method of accomplishment. The word “may” is used to indicate an acceptable method of accomplishment.

2.3 – Front Panel Overview



1. **“Push to Test” Button** – Displays current battery charge state when pressed.
2. **DC Output Receptacle** – Provides output of 28.5 Vdc @ 200 amps (3000 amps peak)
3. **Air Intake Fan** – Provides active cooling for internal components.
4. **LED Charge Status Meter** – Displays current battery charge status when pressed.
5. **50 Amp Twist-Lock AC Power Cord** – Provides 33.5 amps @ 208 Vac 60Hz (50 amp service required).
6. **External AC Circuit Breaker** - Protects the internal electrical circuit from damage caused by overload or short circuit.
7. **Interface Connector** - Used for factory calibrations.
8. **Telescopic Handle** – Allows for easy transport of unit (removed to show panel).

2.4 – General Specifications

Electrical

AC Input Power:

- Single Phase 200-260 Vac / 40 Hz - 450 Hz
- 6.5 kW active Power Factor Correction
- 33.5 amps @ 208 Vac 60 Hz
- 50 amp Service Required
- Contact Tesla™ Industries for Plug Configuration

Power Cell:

- Dry, High Rate Discharge, Rechargeable , Maintenance-free

PFC:

- 99.95% EFF (efficiency)
- 1% THD (Total Harmonic Distortion)

DC Output:

- 3000 peak starting amps
- 200 amps continuous @ 28.5 Vdc - 5700 Watts (when plugged into ac power)
- 246 amp hours (6,724 watt hours) with ac power
- 46 amp hours (1,024 watt hours) of rechargeable battery power without ac power

Rechargeable Rate:

- 19 minutes (from full discharge) @ 25 °C

Size:

- 49" long x 19.25" wide x 16" high
- 1244.6 mm x 488.95 mm x 406.4 mm

Weight

- 177 lbs (80.28 kg)

Operating Temperature:

- -40 °C to +60 °C (-40 °F to 140 °F) without ac power
- -40 °C to +55 °C (-40 °F to 131 °F) with ac power

Storage Temperature:

- -65 °C to +105 °C (-85 °F to 221 °F)

Cell Capacity:

- +40 °C 110% ± 05%
- +25 °C 100% ± 05%
- +00 °C 80% ± 05%
- -20 °C 65% ± 10%
- -40 °C 50% ± 10%

2.5 – Physical Dimensions

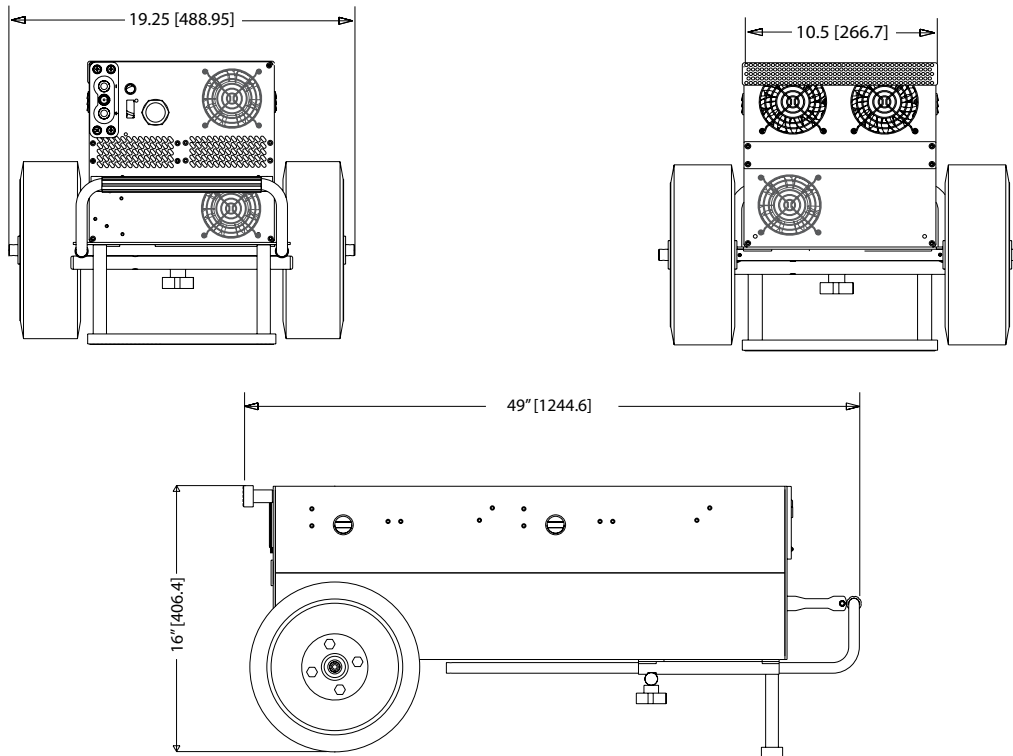

Figure 3.2.1 – TI5200 GPU-24-PFC physical dimensions

2.6 – Airflow Ports

CAUTION Damage may occur if the unit's air intake or outlet ports are obstructed. Ensure that ports are clear at all times.

When the unit is plugged into ac power, the internal cooling system will efficiently regulate unit temperature regardless of load. At room temperature (+77 °F) the exhaust air will not exceed the ambient temperature by more than 5 °F. In more extreme temperatures (greater than 90 °F) the exhaust air will not exceed the ambient temperature by more than 10 °F.

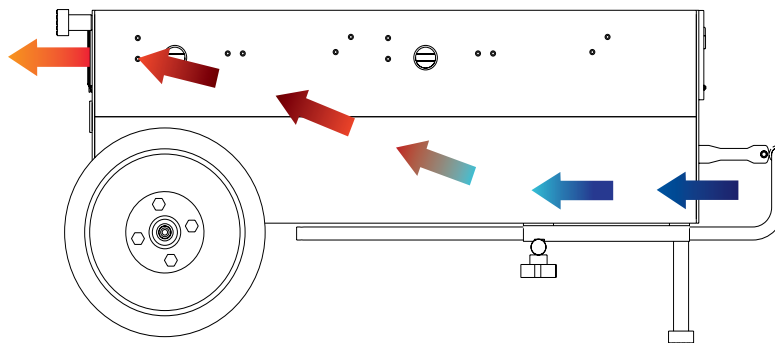
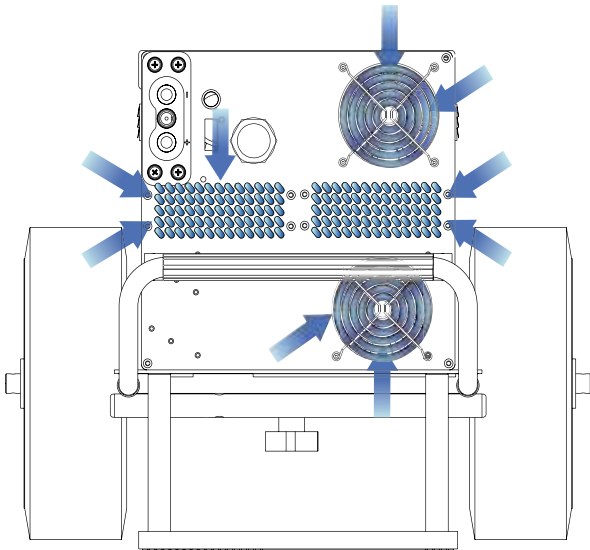

Figure 3.3.1 – Air intake and exhaust ports and internal air circulation

2.7 – Operating Positions

The TI5200 GPU-24-PFC can be operated in both the horizontal and vertical positions as shown. Make sure that the airflow is not obstructed from air intake and outlet.



Front Inlet

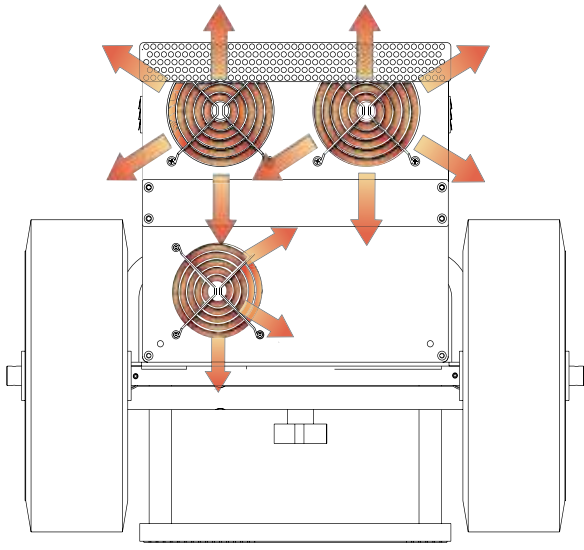

Rear Outlet

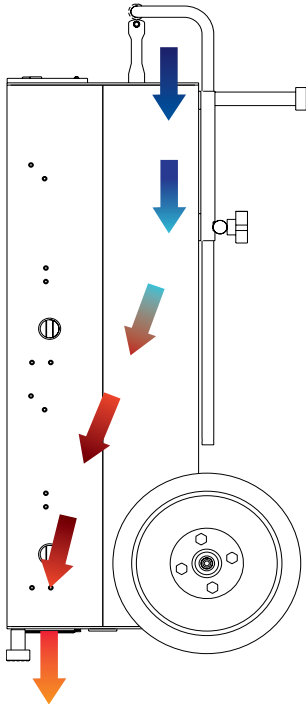

Vertical Position

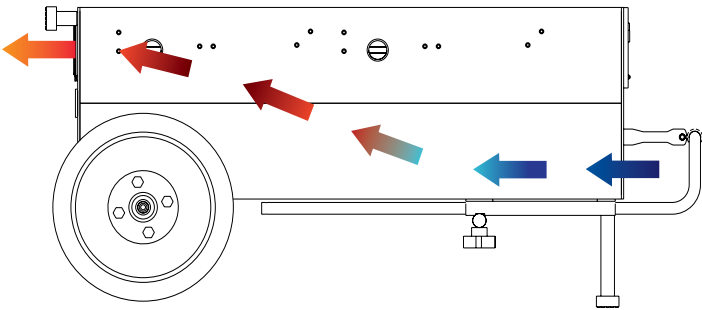

Horizontal Position

2.8 – “Push to Test” Button and LED Status Indicator

The “Push to Test” button is used to indicate the capacity of the power cells without applying ac input power. It allows the end user to check the status of the power cells. This lets the operator know if there is enough power to perform another engine start, or if the unit has to be connected to ac power to allow it to recharge.

1. Make sure that you wait at least 2 minutes after ac power is applied, or dc power is extracted from the unit, before you press the “Push to Test” button. This will ensure a correct reading.
2. Without ac power input or dc power output, simply press the “Push to Test” button on the faceplate and hold for approximately 2 to 3 seconds.
3. At this time the LED bar graph should light up indicating the status of the power cells.
4. The fan should also operate at this time. If you do not hear the fan running, stop pressing the button and check for any obstructions to the fan.

!
CAUTION

Never press the “Push to Test” button while the unit is plugged into ac power for recharge, or plugged into aircraft for dc power output.

!
CAUTION

Never press the “Push to Test” button for more than 5 seconds. This may cause a temperature sensor to temporarily disrupt “Push to Test” function. (If this sensor is tripped, allow ten minutes for unit to cool before operating “Push to Test” button.)

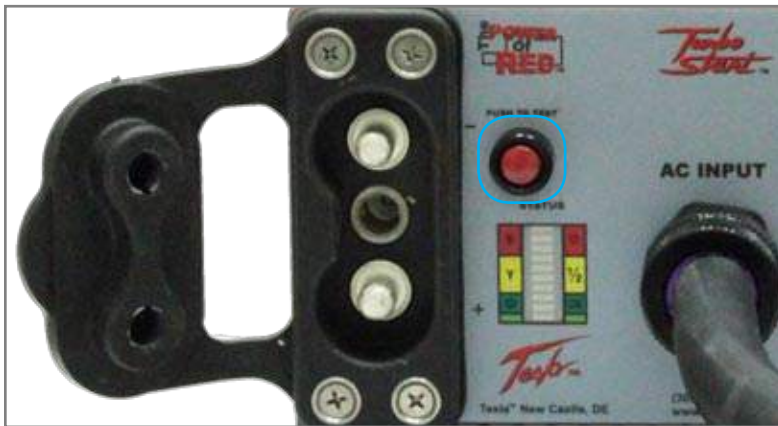
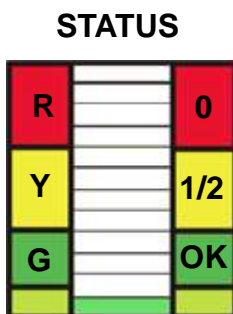

Figure 2.8.1 - “Push to Test” button location
(outlined in blue)



Figure 2.8.2 - Pushing to Test



Full Charge

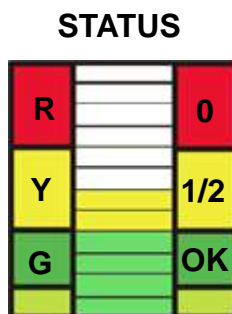

Half Charge

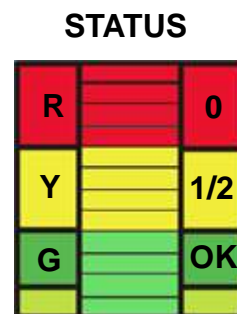

No Charge

2.9 – Active Power Factor Correction

In electric power systems, a power supply with a low Power Factor will draw more current than the same power supply with a high Power Factor while doing the same work.

Power Factor (PF) in ac systems is defined as the ratio of the real power W (watts) flowing to the load over the apparent power VA (volts-amps) in the circuit. This is represented by a number between 0 and 1. For example: this is a percentage .75PF=75%PF.

A power supply is considered to be a non-linear load in which the ac power is rectified and then filtered. It is these non-linear loads that reshape the current waveform into something different introducing harmonics and distortion known as THD (Total Harmonic Distortion).

THD is defined as the ratio of the sums of all the powers of the harmonics to the power of the fundamental frequency (i.e. the fundamental frequency would be the line frequency 60 Hz and the 2nd order harmonic=120 Hz, the 3rd order=240 Hz, etc.).

$$\text{THD} = \sqrt{\frac{\sum_{n \neq 1} I_n^2}{I_1^2}} \quad \text{PF} = \sqrt{\frac{1}{1 + \text{THD}^2}}$$

When the mains instantaneous voltage exceeds the voltage of the Input Capacitors the Rectifiers conduct which causes a current spike (see Figure 2.8.1). These spikes induce harmonics and distortion. These additional harmonics over the fundamental frequency are what contribute to a poor Power Factor. The higher order harmonics in the ac current cause the skin effect of the conductors carrying the ac currents to the load to increase.

Skin effect in ac circuits is where the higher frequency currents do not penetrate the entire conductor due to the opposing eddy currents causing them to ride along the surface of the conductor. It is these magnetic fields, generated by the eddy currents, which cause the resistivity of the conductor to increase with frequency.

This means the conductor needs to carry additional currents plus the load current to compensate for the higher order harmonics. These extra currents generate magnetic fields and are stored in the power lines, the switch gear and the power supply. They then return back to the power grid during the off periods of the cycle resulting in wasted energy in the form of heat.

Tesla™ Industries was able to develop a wide bandwidth active Power Factor Correction that runs from 40 Hz to 400 Hz which pulls unity power only at the fundamental frequency. This was achieved by forcing the current to follow the voltage waveform (see Figure 2.8.2) so that current is pulled through the entire sinusoidal waveform on a cycle-by-cycle basis. This eliminates the current spikes and strips out the additional harmonics causing a massive increase in efficiency.



Figure 2.9.1 - Non-PFC Power Supply

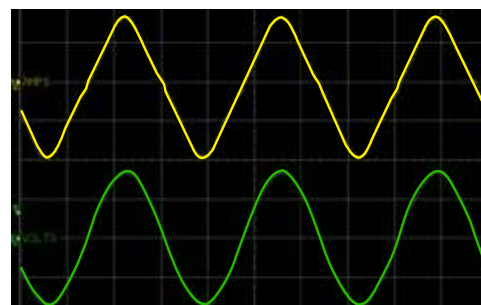

Figure 2.9.2 - Tesla's PFC Power Supply

2.10 – AC Input Circuit Breaker

This unit is equipped with a 50 Amp AC Input Circuit Breaker located above the AC Input Connector. The AC Input Circuit Breaker acts as an “On/Off” switch for the unit.

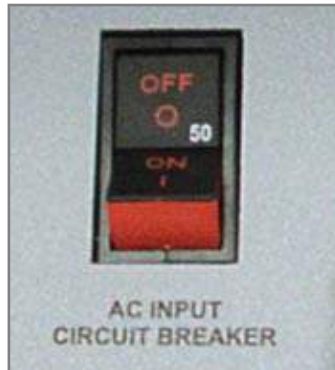

Figure 2.10.1 - AC Input Circuit Breaker

2.11 – AC Line Cord

The ac line cord is a 25' long S00W 600 Volt 8/3 Cable with a 50 Amp Twist Lock. (TI25000-058 (CS8265) 25ft. Hardwired Single Phase Plug AC Line Cord) 50 Amp service is required to use the unit. Contact Tesla™ Industries for additional plug configurations.



Figure 2.11.1 50 Amp Twist Lock AC Line Cord

2.12 – 24 Vdc Output Connector

The 24 Vdc Output Connector will provide 100 Amps of continuous power @ 28.5 Vdc (when plugged into ac power). When the Output Connector is not in use, cover the receptacle with the protective cover (see Figure 2.12.1). This will protect the Output Connector from dust and foreign matter.

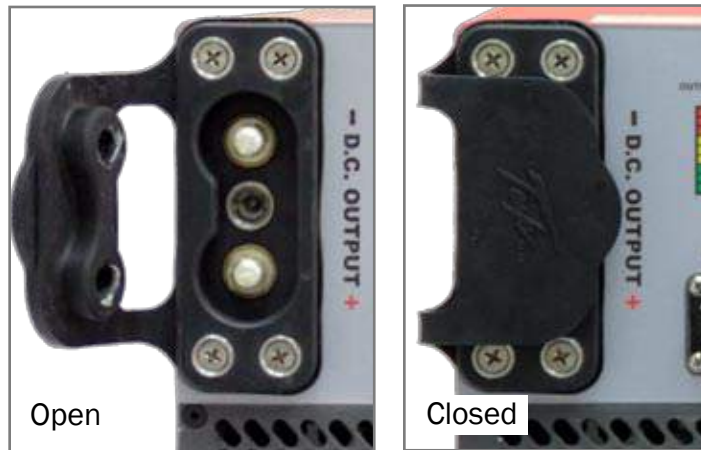

Figure 2.12.1 24 Vdc Output Connector Protective Cover

2.13 – Interface Connector

The Interface Connector is used by a Tesla™ factory technician to calibrate the unit.





Figure 2.13.1 - Interface Connector location

Section 3 – Operating Procedures

3.1 – Operating Procedures

This section deals with normal procedures, and includes all steps necessary to ensure safe and efficient operation of the unit.

 NOTE	When the unit is not in use, it should always remain plugged into a suitable ac power source to ensure operational readiness at all times.
---	--

 NOTE	If current demand exceeds 200 amps, converter output voltage will drop below 28.5 Vdc and two or more LED status indicator bars will illuminate. If all LED status indicator bars illuminate, both the converter and power cells are supplying 24 Vdc power output.
---	---

3.2 – General

Correct operation of the unit includes both pre-use and operational checks of the unit. Knowledge of the operating limits, restrictions, performance, unit capabilities and functions is fundamental to correct and safe operation. The operator shall ensure compliance with the instructions in this manual that affect operational safety and the warranty of the unit.

3.3 – Operating Limits and Restrictions

The minimum, maximum and normal operating ranges result from careful engineering and evaluation of test data. These limitations must be adhered to during all phases of operation.

3.4 – Performance

Refer to Section 7, PERFORMANCE DATA to determine the capability of the unit. Consideration must be given to changes in performance resulting from variations in ambient temperature, mode of operation, state of charge (with or without ac power), and aircraft dc bus system inefficiency (voltage drops).

3.5 – Engine Starting Power

Operators should always ensure the unit is charged above 80% prior to ground support engine starting. However, circumstances may exist during use where unit recharge is not readily available and immediate external engine starting power is required. The following provides minimum states of charge necessary to provide ample power for an efficient engine start under specific current load demands.

ENGINE START PEAK CURRENT Requirements

Under 1200 peak starting amps
1200 - 1500 peak starting amps
1500 - 1800 peak starting amps
1800 - 2100 peak starting amps
2100 - 2400 peak starting amps
2400 - 3000 peak starting amps

MINIMUM CHARGE

0-40% charged
40-50% charged
50-60% charged
60-70% charged
70-80% charged
80-100% charged

3.6 – Temperature Specifications

Cold/Hot Soaked Temperature

The ambient temperature that a unit is exposed to for one (1) hour or more establishes the unit’s cold/hot soaked stabilization temperature. If the unit’s cold/hot soaked temperature is outside the normal operating temperature range, the unit must be stabilized prior to operation. For COLD SOAKED temperature stabilization, the unit must be placed in an environment with a temperature above +10°C (+41°F) for 3 hours or a temperature above +20°C (+68°F) for 2 hours. For HOT SOAKED temperature stabilization, the unit must be placed in an environment with a temperature below +38°C (+100°F) for 1 hour.

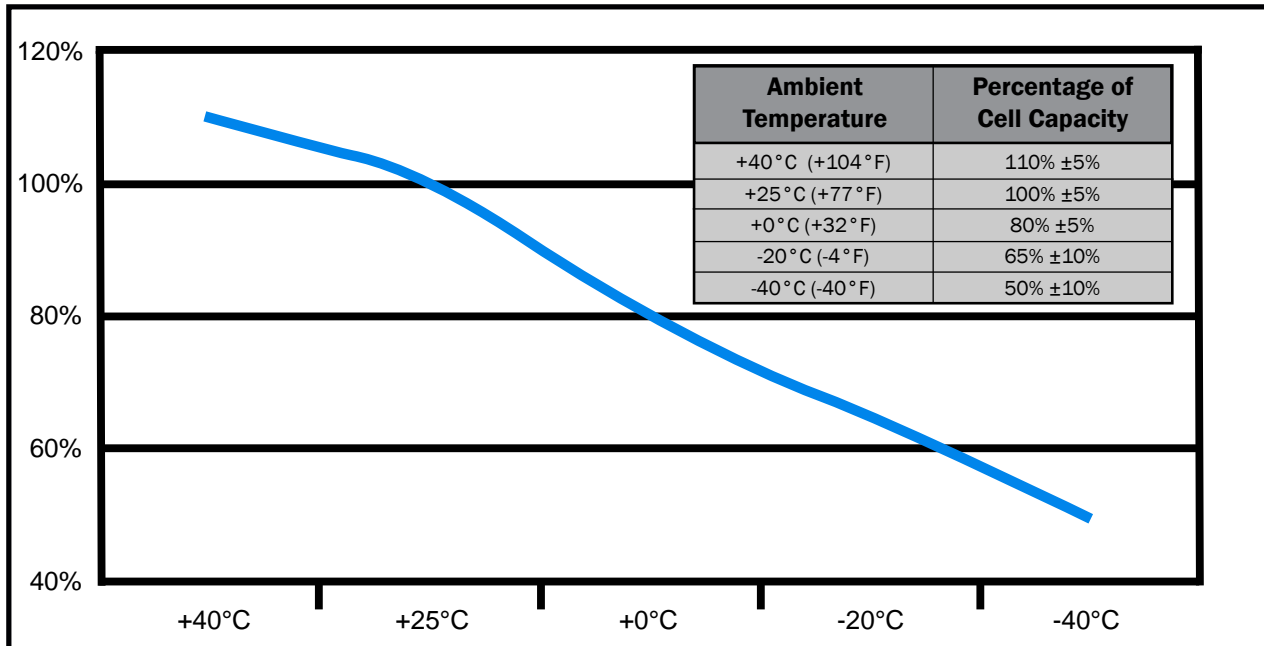



Figure 3.6.1 – Output power capability versus ambient temperature

Hot Soaked or Cold Soaked Definition

Simple terms: When a material is exposed to a change in temperature, its temperature will also change. Some material changes temperature quickly, others slowly. If the ambient temperature changes and is then held constant, the materials temperature will also change until its temperature stabilizes. Once the material temperature has stabilized, it is considered “soaked”.

Example: The unit is moved from the cool shade into the hot sun. The unit’s temperature will increase until it stabilizes. Once stabilized, the unit would be considered “hot soaked”.



NOTE

The unit is equipped with a temperature switch that automatically disables AC power functions when the internal temperature is above 150°F (65°C). This protects the unit from overheating and damage. If the unit shuts down, move the unit into a cooler climate such as shade or air conditioning when possible. Perform a full function test prior to use after the unit has been allowed to cool.

3.7 – Environmental

 <b style="font-size: 1.2em; margin-left: 10px;">WARNING	<p>Operating any electrical equipment in the presence of moisture creates possible safety hazards and/or potential for equipment damage. Every effort has been made, within the scope of existing technology to prevent foreseeable safety hazards and make the unit moisture resistant to prevent damage or failure.</p>
---	---

If the unit is exposed to moisture, preventive measures and precautions shall be taken to:

- A. Prevent accumulation of moisture on ac and dc connectors/receptacles
- B. Minimize moisture entering forward inlet and aft outlet cooling fan vent ports

Unit inlet and outlet vent ports shall be covered from exposure. Unit shall be kept horizontal. It is recommended that the Tesla™ Protective Rain Cover be fitted onto the unit to guard it from moisture (see Section 8). The limits and operational constraints listed below shall apply for the following environmental (weather) conditions:

Conditions	With Raincover	Without Raincover
Heavy or steady rain: <i>Precipitation falling with an intensity in excess of 0.30 inch (0.76 cm) or continuously between 0.30 and 0.10 inch per hour.</i>	OK	OPERATION NOT RECOMMENDED
Light rain, drizzle or sleet: <i>Precipitation falling on a continuous basis between 0.10 inch and less than 1/50 inch (0.5 mm) per hour</i>	OK	DC OPERATIONS ONLY
Heavy or steady snow: <i>Generally meaning an accumulation between 4 inches and less than 1 inch in a 12 hour period.</i>	OK	OPERATION NOT RECOMMENDED
Light snow: <i>Snow falling intermediately with little or no accumulation.</i>	OK	DC OPERATIONS ONLY
Fog:	OK	OK



Figure 3.7.1 – TI5200 GPU-24-PFC with TI7000-104 Protective Rain Cover

3.8 – Normal Function Test Procedures

This section deals with “normal function” test procedures, and includes all steps necessary to ensure that the TI5200 GPU is operating within specified parameters prior to use. A digital multimeter (an example is shown in Figure 3.8.1) capable of measuring dc and ac voltage and resistance will be required to perform some of the tests. These functional test procedures should become routine.



Figure 3.8.1 – Digital Multimeter

Check Unit for Evidence of Damage

Check for dents, punctures, case distortion or misalignment, and cracked or loose connectors. If no damage is evident, proceed to the next step. If damage is evident, contact Tesla™ Industries, Inc.



Figure 3.8.2 – Damaged Unit
Misaligned Case with Bent Faceplate

Check Unit Internal Resistance (Test for Shorts)

This section deals with “normal function” test procedures, and includes all steps necessary to ensure that the TI5200 GPU is operating within specified parameters prior to use. A digital multimeter (an example is shown in Figure 3.8.1) capable of measuring dc and ac voltage and resistance will be required to perform some of the tests. These functional test procedures should become routine.



NOTE

Unit should be disconnected from any ac power sources prior to testing.



1. Place the negative probe on the ac ground probe and the positive probe on the case.



2. Move the positive probe to the dc positive post.



3. Move the positive probe to the dc negative post.

Better than 10 MΩ, ensure no short exists.

Negative(-) DC receptacle terminal and unit case.

Positive (+) DC receptacle terminal and unit case.

Check DC Voltage Reading at DC Receptacle Terminals

26.5 to 28 Vdc depending on state of charge.



Figure 3.8.3 – Testing DC Receptacle

3.9 – Pre-Operation

1. Be sure to check that all input and output cables are not damaged. (see section 5.1)
2. Check unit carefully for any evidence of damage. (see section 3.8)
3. Make sure that airflow is not obstructed from air intake and outlet. (see section 2.6)
4. Check that all connections are secure and free from water.



Figure 3.9.1 TI5200 GPU-24-PFC

3.10 – Transporting Unit

The TI5200 GPU-24-PFC has a telescoping handle that makes rolling the unit easy. For transporting on uneven ground, axle extensions should be added to the unit. For use on sand, balloon tires should be installed on the unit (see Optional Accessories).

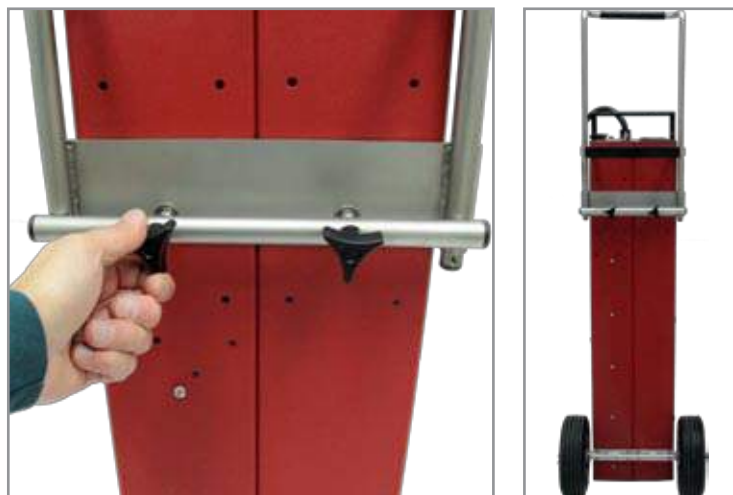

Figure 3.10.1 Releasing Telescopic Handle

3.11 – Regulated 28.5 Vdc Ground Power

Connecting DC Power Cable To Unit

Ensure dc power cable plug is fully seated into the GPU's DC Battery Receptacle. Attaching a dc plug is quick and easy. Line up the plug with the receptacle. Push forward while rotating the T-handle one full turn clockwise. The unit is now ready to safely transfer power.



Figure 3.11.1 Attaching DC Power Cable to TI5200 GPU-24-PFC

Connecting DC Power Cable To Vehicle or Aircraft

Line up the NATO plug or aviation dc plug pins and push it in. DC bus power should come on and aircraft voltmeter should indicate 24 Vdc to 23.5 Vdc (23 Vdc minimum). Ensure dc power cable plug is fully seated into the vehicle or aircraft's dc receptacle.



Figure 3.11.2 Attaching NATO DC Power Cable to vehicle



Figure 3.11.3 Attaching an Aviation DC Power Cable to aircraft

Low Power Demand

Low power demand is defined by a requirement of 200 amps or less. Connect dc power to aircraft ground power receptacle. DC bus power should come on and aircraft voltmeter should indicate 28.5 Vdc to 27 Vdc (26.5 Vdc minimum). If aircraft power demand is less than 200 amps converter output will remain at 28.5 Vdc (only one GREEN LED status indicator bar will illuminate). If aircraft power demand exceeds 200 amps converter voltage output will decrease and two or more LED status indicator bars will illuminate.

High Power Demand

High power demand is defined by a requirement of more than 200 amps. Connect to aircraft ground power receptacle. DC bus power should come on and aircraft voltmeter should indicate 27.5 Vdc to 23.5 Vdc (23 Vdc minimum). If current demand is above 200 amps, converter output voltage will drop below 28.5 Vdc and two or more LED status indicator bars will illuminate. If the red LED status is displayed, the unit has dropped down to 24.5 Vdc.



NOTE

When all LED status indicator bars illuminate, both the converter and power cells are supplying 24 Vdc power output for current demands above 200 amps.

Engine Starting



CAUTION

Unplug ac power cord before starting engine with unit.

Prior to engine start, ensure power cell charge is sufficient to provide an efficient engine start. Check dc power cable for secure and correct installation prior to engine starting. Follow ground power engine starting procedure as specified in vehicle operator's manual.

Removing DC Power Supply From Aircraft or Vehicle

1. Remove dc power cable GPU connector from vehicle.
2. Remove dc power cable connector from TI5200 GPU-24-PFC (if necessary).
3. Reinstall dc receptacle's protective cover.



Figure 3.11.3 Starting vehicle with TI5200 GPU-24-PFC

3.12 – Operating with a Digital Volt/Amp Meter

The DVAM (Digital Volt/Amp Meter) 3100A provides measurements for all voltage ranges and amperage draws between zero and 2,000. The DVAM 3100A indicates the aircraft or vehicle's current demand. Integrated with the Tesla™ GPU power supply, the DVAM is a valuable tool for troubleshooting and system checks.

The left meter indicates dc voltage output and the right meter indicates amperage draw. The meter's range changes from 0-200 amps to 0-2,000 AMPS with the flip of a switch. The 200 amp setting provides a more detailed reading extending to two decimal places. The 2,000 amp setting reads higher currents such as engine starts and in rush currents.



Figure 3.12.1 DVAM 3100A

3.13 – Regulated AC Power

Plugging in with AC Power

When the TI5200 GPU-24-PFC is plugged into ac power, the output is 28.5 volts. This voltage allows the system to recondition and recharge the vehicle's battery(ies). It is also an optimum voltage for powering avionics and lighting on most aircraft. The GPU's ac to dc converter produces continuous amps of dc power depending on the size of the system.



Figure 3.13.1 Connecting TI5200 GPU-24-PFC to AC Power Supply

Connect DC Power Cable To Unit

Ensure dc power cable connector is fully seated into unit's receptacle (if necessary).



Figure 3.13.2 Connecting TI5200 GPU-24-PFC to AC Power Supply with DC Power Cable Attached

3.14 – Charging Unit

Once you have the fuse set to match the power characteristics of your line cord, you can plug the unit into a wall socket to charge the batteries. Until the unit is fully charged, the LED status will read half or no charge.



Figure 3.14.1 Connecting TI5200 GPU-24-PFC to AC Power Supply

If you received this manual with a new GPU.

Under a full charge the LED indicator should show a single steady green bar or a single green bar blinking. The fan will also come on at reduced speed. This is normal operation indicating the unit is in standby mode and is ready for use.

If you own an older GPU and this is a replacement manual.

Under a full charge the LED indicator should show a single steady green bar or the entire LED will be blinking. The fan will also exhibit ratcheting but will not come on. This is normal operation indicating the unit is in standby mode and is ready for use.

If the GPU's cells need to be replaced.

After one and a half hours (90 minutes) of ac power input the unit should be fully charged. If the “Push to Test” button is pressed and the unit still indicates it is not fully charged then the cells should be replaced.



CAUTION

The ON/OFF switch located on the faceplate does not control the DC output power function.

3.15 – Circuit Breaker Switch

The TI5200 GPU-24-PFC comes equipped with a circuit breaker switch on the front faceplate. This switch controls ac power input only, It does not control the dc output power to the aircraft or vehicle. Whenever the unit is plugged into an aircraft or vehicle, it is supplying dc power.

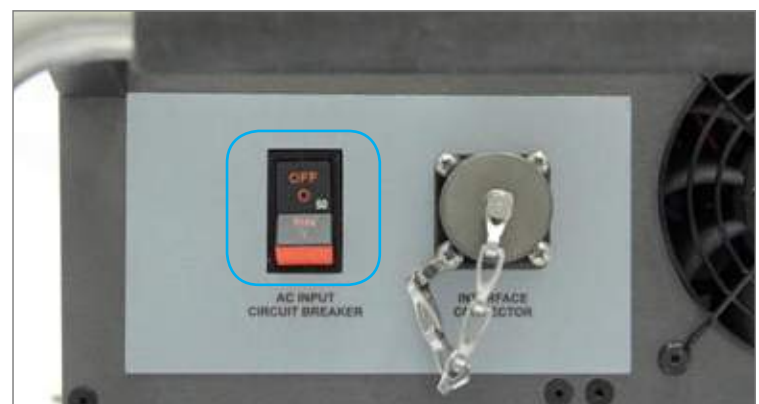

Figure 4.2.1 Circuit Breaker Selector Switch
(outlined in blue)

Section 4 – Post Operation

4.1 – General

Although the TI5200 GPU-24-PFC has been ruggedized and made weather resistant within the scope of unit's intended use, it is essential that good general care be taken to maintain unit in good operating condition and to maximize unit's operational life.

4.2 – After Use

Unit should be protected from environmental elements and man made hazards. Ideally unit should be secured in a building or shed. Most importantly, unit shall be fully covered if stored while exposed to environmental elements.

4.3 – Power Cell Recharge



NOTE

The TI5200 GPU-24-PFC incorporates a backcharge feature that enables the unit to be recharged from the vehicle once the engine is started and the starter/generator is running. This feature will enable you to start multiple vehicles without reconnecting to ac power if the GPU is allowed to backcharge for approximately 30 seconds.



NOTE

Plug the TI5200 GPU-24-PFC into ac power to keep the cells charged whenever it is not in use, even if it is at Full Charge. The unit will not overcharge or overheat.

Connect AC Power Cord to Unit

Ensure power cord is properly connected to an approved ac power supply. After approximately 5-8 seconds, ensure unit's LED status indicator illuminates indicating power cell state of charge and cooling fan is operating.

Any time the unit's power cells are fully discharged the unit shall be recharged within 24 hours to prevent performance degradation and ensure maximum life.



Figure 4.3.1 Connecting TI5200 GPU-24-PFC to AC Power Supply

**CAUTION****Guard From Incorrect Power Source**

The TI5200 GPU's power cells may be damaged if recharged by NiCad or Lead Acid-type battery chargers. Power cells should only be charged by either the TI5200 GPU's internal charger and the ac power cord furnished with the equipment, or when connected to aircraft's external dc power receptacle.

**NO**

Figure 4.3.2 Proper and Improper Charging Methods

Section 5 – Unit Care and Maintenance



WARNING

Severe injury or death from electrical shock may occur if either the user or the unit is wet while operating the unit with an ac power source attached.



CAUTION

Damage may occur if an unapproved or modified ac line cable or input plug is attached to the unit. Do not use any type of ac voltage converter.

5.1 - Unit Care

Avoid Prolonged Exposure to Extremely Damp Environments

Be sure to disconnect ac power from the ac source if the unit has come into contact with water. If the AC Input Circuit Breaker has tripped due to water infiltration, allow the unit to dry out before attempting to reset circuit breaker. Cover the unit to prevent water seepage. If the unit is operated in extremely damp conditions, it should be stored in an environmentally controlled building when not in use. Wipe unit clean periodically with a soft cloth to remove dust, dirt, etc.



Protect Cables from Damage

Do not cut, crush, or drag the input or output power cables when handling the unit. Always inspect cables prior to use. If no damage is evident, proceed to the next step. If damage is evident, contact Tesla™ Customer Service. Do not attempt to use any other type of power cables other than the Tesla™ cables included with the unit.



Figure 5.1.1 – Damaged cable

5.2– Unit Servicing

This unit is a maintenance-free, sealed unit. No repairs outside of Tesla™ are authorized. Warranty will be voided if unit is tampered with in any way including any damage to the WARRANTY VOID stickers located on the case (see Figure 5.2.1 below). If the unit requires maintenance, please contact Tesla™ Customer Service at (302) 324-8910. A Repair Request Form can be found in the back of this manual.



Figure 5.2.1 – Warranty Void stickers Front and Back on the unit

5.3 – Packaging and Shipping

When returning the GPU, please ensure that it is properly packaged. The only method for transport is in a sturdy shipping crate or Tesla™ Shipping Case (be sure to enclose the Repair Request Form). Seal the crate on all sides and return it to Tesla™ at the address listed below. Please contact Tesla™ Customer Service at (302) 324-8910 with any questions or concerns.

TESLA™ INDUSTRIES, INCORPORATED
101 CENTERPOINT BLVD.
CENTERPOINT INDUSTRIAL PARK
NEW CASTLE, DELAWARE 19720
PHONE: (302) 324-8910 FAX: (302) 324-8912
Website: www.teslaind.com
Email: Tesla1@teslaind.com



Figure 5.3.1 – Tesla™ Industries Shipping Case

5.4 – Storage

If unit can not be connected to ac power while in storage, we recommend to charge the unit once a year. The shelf-life of 12 months is due to the battery /cells inside the unit. We guarantee the unit will hold 80% of its charge for a period of 12 months without being recharged. When the GPU's leave the facility, they are fully charged and if they are to go into storage (without being used), they will maintain 80% of their charge after 12 months. The life expectancy of the units, if maintained properly, is 5 to 7 years.

Section 6 – Troubleshooting and FAQ

6.1 – Frequently Asked Questions

1. Why should I buy a Tesla™ Turbo Start™ System?

Tesla™ Turbo Start™ is a multi-functional system that are ideal for support of 24 Vdc vehicles and aircraft and their electronics/avionics on the bench. Tesla™ manufactures various systems of different sizes and capacities that are man-portable, maintenance free and provide pure, dc power in a completely safe package. Designed for Military applications, these systems are equally valuable in maintenance support at the main facility or in remote locations. They are easily transported and air-portable. They will also provide 28.5 Vdc when the system is connected to the appropriate ac source.

2. How does a Turbo Start™ work?

The Turbo Start™ combines state of the art power conversion electronics with our proprietary “dry cell” batteries. The system’s electronics incorporate an intelligent charging system for the cells. The cells are ideal for this application as they are non-spillable, absorbed electrolyte dry cells that are sealed, maintenance free and safe for air transport.

3. How is Turbo Start™ used in Aviation Support?

There are many ways a Turbo Start™ will benefit your operation. By using it for pre-flight testing, you will avoid depleting the aircraft’s battery. You can start the aircraft’s engine with the Turbo Start™ as well. In the hangar, when connected to ac power, the Turbo Start™ will provide 28.5 Vdc for avionics testing and will also recondition and recharge the aircraft’s battery. Another benefit is the ability to fly with the Turbo Start™ aboard your aircraft. You may take the Turbo Start™ anywhere you travel, ensuring that you will always have power.

4. How much power will my Turbo Start™ provide?

Depending on the system, the Turbo Start™ will provide anywhere from 1500 to 3500 peak starting amps, 25 to 400 continuous amps dc and 23 to 96 hours of rechargeable power. See our website (www.teslaind.com) to determine the proper Turbo Start™ for your needs.

5. Will a Tesla™ Turbo Start™ spool up a turbine engine?

Nothing will start a turbine engine faster or safer than the right Tesla™ Turbo Start™. Not only will it eliminate hot starts, but it will extend the life of your starter, your engine and your battery while reducing maintenance. The Turbo Start™ senses the impedance from the starter/generator. It then provides the exact power required throughout the start-up curve.

6. How many engine starts will my Turbo Start™ provide until it is depleted?

The Turbo Start™ back-charges, almost instantly, once the vehicle / aircraft is started and the generator is on line. This “power flywheel” feature enables the Turbo Start™ to recharge itself right from the vehicle it started in less than 30 seconds. You can go down the line in your motor pool and start every 24V vehicle, without limit!

7. How do you prolong the life of the Turbo Start’s cells?

All you need to do is plug the unit in to the appropriate ac power outlet the system requires. AC power will recharge the system and keep the cells healthy. Users who regularly plug the system in can expect to get 5-7 years from their cells before they need to be replaced. Tesla™ cells do not have a memory like cell phone batteries. There is no need to fully discharge them. The recharging system will not overcharge the unit or produce excess heat.

8. Is it waterproof?

Water-resistant but not waterproof (See Environmental Section).

9. Are Tesla™ GPUs used in shop maintenance and testing?

Tesla™ systems are gaining popularity throughout maintenance facilities, instructional facilities, laboratories, manufacturing plants, aircraft hangars and many other locations. The reason is due to the precise dc power, the small, portable and quiet nature of our systems and the maintenance free aspect of our GPU's. We can custom tailor ground power systems to fit your individual requirements.

10. Can one person transport it?

Turbo Start™ is designed to be handled by one person. The TI500 is our smallest GPU system to date and weighs 36 lbs. The TI1000 weighs 57 Lbs and can be carried or wheeled on a dolly. Larger units have wheels incorporated directly on the system with an extendable handle.

11. Is the Turbo Start™ in the government purchasing system?

Yes. Tesla™ Industries is an approved vendor/supplier – our cage code is OVWE2. Most Tesla™ products are class IX, have a National Stock Number (NSN) designation and can be acquired through the DLA (Defense Logistics Agency).

12. How long does this unit stay charged?

Unit should never be allowed to discharge fully. In-field use, it receives a dc back charge directly from a running engine. When not in use, unit should be plugged into ac power (outlet) all the time. Tesla™ systems will retain 80% of their capacity after one year of storage.

13. How do I get my Turbo Start™ serviced?

Contact Tesla™. We can be reached at (302) 324-8910. Ask for customer service. You can also email us at tesla1@teslaind.com. Once we receive the unit at our facility, we will examine it. Systems that are protected under warranty will be repaired at no charge. If the warranty has expired, you will receive a quote for necessary repairs prior to work being done. Our turnaround time is 48 hours once repairs are authorized.

14. Can I make my own repairs to unit?

During the warranty period, the unit can only be repaired by Tesla™ Industries for the warranty to remain in effect. Regardless, we strongly recommend allowing Tesla™ to repair any unit as we will analyze the complete system and recalibrate it.

15. What type of maintenance does the Turbo Start™ require?

Although the systems are maintenance free, please keep units plugged in while not in use. This will greatly extend the life of the cells. Also, keep the vent areas clean and free of debris. Keep units in a well ventilated area while charging. Keep the unit in a protected environment when not in use (maintenance facility, shed, etc.).

16. What is included with my Turbo Start™?

Aviation customers will receive an eight (8') foot DC Aviation Cable Assembly (TI2007-208). Ground vehicle customers will receive a fifteen (15') foot DC NATO Cable Assembly (TI2007-315). All customers receive an ac line cord for their home country and a full two year warranty.

17. Are there any HAZMAT issues or disposability problems?

There are none. Tesla™ will reclaim all battery cells for disposability purposes. Contact Tesla™ if you have questions.

6.2 - Basic Usage/Operation Questions

1. What's the best position to place the unit for use vertical or horizontal?

Preferred position is horizontal for stability and airflow considerations. When charging, the preferred position is horizontal. The Turbo Start™ can be put in any position while it is being used as there is nothing to spill inside the system.

2. Does the unit have to be plugged in all the time?

No, but for maximum performance and cell longevity, keep the unit plugged in while not in use.

3. What happens if I don't keep it plugged in?

Unit will eventually lose its charge and cell life is shortened.

4. How do I check the status of the charge?

Press the "Push to Test" LED bar indicator on the unit's faceplate. A fully charged unit will have one green LED light showing.

5. Why is the cooling fan always running when I am plugged into ac power?

Constant cooling fan operation ensures proper and consistent ventilation of the unit.

6. Why does the cooling fan slow down?

Cooling fan rpm varies for better temperature regulation.

7. Why does my LED flicker when the unit is plugged in?

Older Turbo Starts™ indicated a full charge with a flickering LED readout. Newer models feature the illumination of one green bar on the LED readout when the unit is fully charged.

8. What do I do if a circuit breaker trips?

The AC Input Circuit Breaker is located above the AC Input Connector. When the circuit breaker has been tripped, either of the red buttons will pop out. In the event that the breaker trips:

1. Disconnect the ac and dc connectors. (Unplug ac line cord on military unit.)
2. Wait for a minimum of 60 seconds.
3. Reset breaker by pressing red button.
4. Reconnect ac and dc connections to the unit. (Plug in ac line cord on military unit.)

The unit should power up automatically. If the breaker continues to trip, return the unit to Tesla™ Industries for repair.

6.3 - Basic Unit Troubleshooting

Fault	Possible Cause	Remedy
1. Output Capacity LED does not come on when button is pushed.	<p>A. Units cells completely dead.</p>	<p>A. Plug the unit in to the appropriate ac power outlet and recharge.</p> <p>B. If LEDs still do not illuminate, Please contact Tesla™ Customer Service at (302) 324-8910.</p>
2. Unit has no output dc or ac input or both.	<p>A. Units cells completely dead.</p> <p>B. AC line cord is damaged or bad.</p> <p>C. DC line cord is damaged or bad.</p> <p>D. AC circuit breaker has been tripped.</p> <p>E. Cables loose or corroded.</p>	<p>A. Do a function check with digital meter, see section 3.8.</p> <p>B. Do continuity test.</p> <p>C. No continuity, check cables for cuts and replace if needed.</p> <p>D. Clean contacts of debris and make sure connections are tight.</p>
3. Unit will not charge from ac outlet.	<p>A. AC line cord is damaged or bad.</p> <p>B. Is ac line cord fully plugged into unit and wall outlet.</p> <p>C. AC circuit breaker has been tripped.</p> <p>D. No ac power at outlet.</p>	<p>A. Do a continuity test on the ac line cord</p> <p>B. Check if line cord is properly secured.</p> <p>C. Check to make sure ac circuit breaker is placed in the “ON” position.</p>
4. Unit failed function test.	<p>A. Internal failure.</p>	<p>A. Please contact Tesla™ Customer Service at (302) 324-8910.</p>
5. Unit emits sparks when plugged into power source.	<p>A. Water or moisture has seeped in unit</p> <p>B. Internal failure.</p>	<p>A. Move unit to dry warm air and allow to dry for over 48 hours.</p> <p>B. Do Not Use Unit. Please contact Tesla™ Customer Service at (302) 324-8910.</p>
6. Unit works then shuts down.	<p>A. Unit is overheating.</p> <p>B. Cooling fans and vents are obstructed or inoperable.</p>	<p>A. Move the unit to an area 10° -20° less ambient temperature.</p> <p>B. Clean and clear cooling vents, turn on unit and inspect if air is flowing through unit. If no airflow please contact Tesla™ Customer Service at (302) 324-8910.</p>

Fault	Possible Cause	Remedy
7. Circuit breaker continuously trips	A. Unit is overheating.	A. Disconnect unit from ac input and dc output. B. Switch breaker to ON position. C. Reconnect unit to cables and run. D. If LEDs still do not illuminate, Please contact Tesla™ Customer Service at (302) 324-8910.
8. Unit does not put out 28.5 volts dc power.	A. Unit is not plugged in.	A. Plug unit into ac power source to maintain 28.5. B. Stand alone Vdc is 24 Volts (unplugged).
9. Unit stand alone voltage is less than 23 volts.	A. Cells discharged.	A. Plug unit into ac power source. B. Recheck capacity after 25 minutes. C. Failure to hold above 23 Vdc, Please contact Tesla™ Customer Service at (302) 324-8910.
10. Unit weakens after first start.	A. Weak cells.	A. Allow between 30 to 60 seconds backcharge between uses.

Section 7 – Performance Data

7.1 – Purpose

This section provides performance data for the unit. Continual reference to this information will enable the user to obtain maximum performance, utilization and service life from the unit. Although maximum performance is not always required, regular referral to this section is recommended for the following reasons:

- A.** To generate knowledge of unit's performance margins to enable the operator to make sound judgment when unexpected conditions or alternate operational requirements are encountered.
- B.** To enable the user to readily recognize situations requiring maximum performance.
- C.** To gain experience in accurately estimating the effects of variables for which data is not presented.
- D.** To help the operator determine if a vehicle or an aircraft system malfunction exists by comparing actual performance with expected performance.



NOTE

The information provided in this section is primarily intended for operational planning and is most useful when planning operations under unfamiliar conditions or environmental extremes. The data may also be used to establish local operating procedures and to ensure unit's operational life is maximized.

7.2 – General

The data presented covers the maximum range of conditions and performance that can reasonably be expected. In each area of performance, the effects of temperature and dc electrical load demand relating to the ground power support requirements are presented. Wherever practical, data is presented conservatively. However, **NO GENERAL CONSERVATISM HAS BEEN APPLIED**. All performance data presented is within the applicable limits of the unit

7.3 – Data Basis

The type of data used is indicated at the bottom of each performance chart under **DATA BASIS**. The applicable report and date of the data are also given. The data provided generally are based on one of three categories:

- A.** Derived From Actual Controlled Testing: Controlled test data obtained on a similar unit type.
- B.** Calculated Data: Data based on tests, but not on a similar unit type placed under a controlled test.
- C.** Estimated Data: Data based on estimates using rules of physics, mathematics, and electrical engineering principles and concepts, but not verified by tests.

7.4 – Specific Conditions

The data presented are accurate only for specific conditions listed under the title of each chart or graph. Variables for which data are not presented, but which may affect that phase of performance, are discussed in associated text. Where data is available or reasonable estimates can be made the amount that each variable affect performance will be given.

7.5 – General Conditions

In addition to the specific conditions, the following general conditions are applicable to the performance data.

- A.** Variation in Aircraft: Power demand differences between individual aircraft of the same make and model are known to exist due to variations in dc electrical system efficiency. These differences, however, are considered insignificant and are not individually accounted for.
- B.** Ground Support and Aircraft Instrument Variations: The data shown in the performance charts do not account for instrument tolerance differences or inaccuracies.

7.6 – Temperature Conversion Chart

°C	°F	°C	°F	°C	°F	°C	°F
-60.0	-76.0	-27.0	-16.6	6.0	42.8	39.0	102.2
-59.0	-74.2	-26.0	-14.8	7.0	44.6	40.0	104.0
-58.0	-72.4	-25.0	-13.0	8.0	46.4	41.0	105.8
-57.0	-70.6	-24.0	-11.2	9.0	48.2	42.0	107.6
-56.0	-68.8	-23.0	-9.4	10.0	50.0	43.0	109.4
-55.0	-67.0	-22.0	-7.6	11.0	51.8	44.0	111.2
-54.0	-65.2	-21.0	-5.8	12.0	53.6	45.0	113.0
-53.0	-63.4	-20.0	-4.0	13.0	55.4	46.0	114.8
-52.0	-61.6	-19.0	-2.2	14.0	57.2	47.0	116.6
-51.0	-59.8	-18.0	-0.4	15.0	59.0	48.0	118.4
-50.0	-58.0	-17.0	1.4	16.0	60.8	49.0	120.2
-49.0	-56.2	-16.0	3.2	17.0	62.6	50.0	122.0
-48.0	-54.4	-15.0	5.0	18.0	64.4	51.0	123.8
-47.0	-52.6	-14.0	6.8	19.0	66.2	52.0	125.6
-46.0	-50.8	-13.0	8.6	20.0	68.0	53.0	127.4
-45.0	-49.0	-12.0	10.4	21.0	69.8	54.0	129.2
-44.0	-47.2	-11.0	12.2	22.0	71.6	55.0	131.0
-43.0	-45.4	-10.0	14.0	23.0	73.4	56.0	132.8
-42.0	-43.6	-9.0	15.8	24.0	75.2	57.0	134.6
-41.0	-41.8	-8.0	17.6	25.0	77.0	58.0	136.4
-40.0	-40.0	-7.0	19.4	26.0	78.8	59.0	138.2
-39.0	-38.2	-6.0	21.2	27.0	80.6	60.0	140.0
-38.0	-36.4	-5.0	23.0	28.0	82.4	61.0	141.8
-37.0	-34.6	-4.0	24.8	29.0	84.2	62.0	143.6
-36.0	-32.8	-3.0	26.6	30.0	86.0	63.0	145.4
-35.0	-31.0	-2.0	28.4	31.0	87.8	64.0	147.2
-34.0	-29.2	-1.0	30.2	32.0	89.6	65.0	149.0
-33.0	-27.4	0.0	32.0	33.0	91.4	66.0	150.8
-32.0	-25.6	1.0	33.8	34.0	93.2	67.0	152.6
-31.0	-23.8	2.0	35.6	35.0	95.0	68.0	154.4
-30.0	-22.0	3.0	37.4	36.0	96.8	69.0	156.2
-29.0	-20.2	4.0	39.2	37.0	98.6	70.0	158.0
-28.0	-18.4	5.0	41.0	38.0	100.4	71.0	159.8

7.7 – Output Voltage

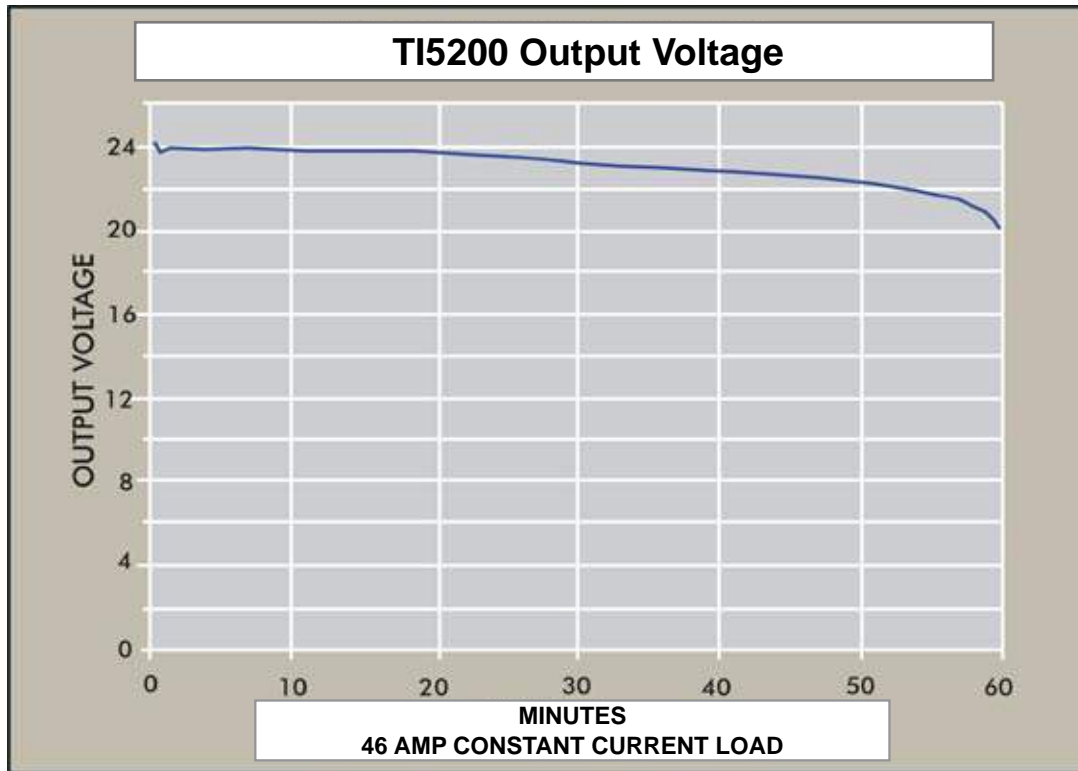

7.8 – Maximum Output Current

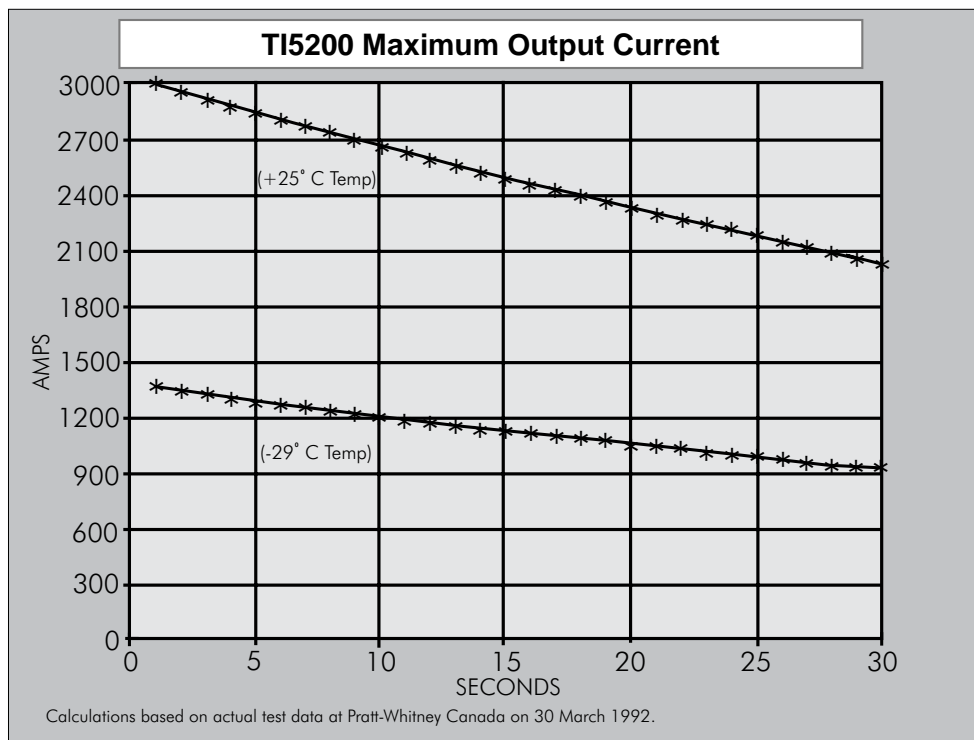

Section 8 – Optional Accessories

8.1 – Shipping Case

The optional Shipping Case is the safest way to transport the TI5200 GPU-24-PFC. This custom case weighs 95 lbs and comes equipped with side handles and locking latches.

TI7000-175

Length: 54.5" (1384.3 mm)
Width: 23.5" (596.9 mm)
Height: 20.5" (520.7 mm)
Weight: 95 lbs (43.09 kg)



8.2 – GPU Protective Covers

Protective unit from moisture, sand and other damaging elements. Custom fit for the TI5200 GPU-24-PFC.

TI7000-104



8.3 – Digital Volt/Amp Meter (TI3100A)

The Tesla™ Digital Volt Amp Meter is a high powered measuring solution. The DVAM 3100A provides measurements for DC voltage from 12 to 32 V and DC current up to 2000 amps for Aircraft and vehicle. Integrated with the Tesla™ Turbo Start™ GPU power supply, the DVAM is a valuable tool for troubleshooting and conducting systems checks. The DVAM 3100A can be ordered through customer service at Tesla™.



8.4 – GPU Tires

Tesla™ offers several tires in order to meet various customer mobility needs.



TI21000-203

Run-Flat Tire
A solid foam rubber tire. The standard tire for ground power units.



TI21000-237

Run-flat Hybrid Tire
A rugged, puncture-proof, foam-filled tire sized to fit our Hybrid units.



TI21000-192

Balloon Tire
For use on soft sand.

8.5 – Cobra™ DC Replacement Contacts and Tools

Cobra™ DC Plugs are designed to provide reliable high-power connections up to 3000 amps – even in the harshest conditions. Each plug is constructed from a rugged combination of advanced composite materials and corrosion-resistant alloys to maximize durability and connectivity. To extend the life of the Cobra™ Connector included with your unit, replacement contacts, posts, noses and tools can be ordered through the Tesla™ Customer Service.

TI2005-238

Cobra™ Aviation Plug



TI2005-078

Cobra™ NATO Connector
NSN: 6130-01-523-1270 (CL IX)



TI2005-251

DC Aviation Plug
Positive/Negative
Contact



TI2005-654

DC 400Hz Aviation Plug
Positive/Negative
Contact



TI2004-444

NATO Replacement Post
For newer NATO plugs with new style post, indicated by the black tip. Replacement plug uses standard 3/4" deep well socket for installation.



TI2005-250

DC Aviation Plug
3-slotted Connector



TI2005-239

Aviation Insertion/
Extraction Tool



TI2005-121

NATO Negative Contact
NSN: 5999-01-525-0582 (CL IX)



TI2005-117

NATO Positive Post
NSN: 5935-01-523-8914 (CL IX)



TI2004-341

Replacement Nose for
Aviation Plug



TI2004-340

Replacement Nose for
400Hz Aviation Plug



TI2005-126

NATO Negative Contact
Insertion/Extraction Tool
NSN: 5120-01-523-8761 (CL II)



TI27000-082

NATO Positive Contact
Insertion/Extraction Tool
NSN: 5120-01-527-7729 (CL II)



Repair Request Form

Please complete the information below to ensure prompt and accurate service. Include this form with the unit you are returning. Thank you.

Date of return: _____

Company name & _____

Billing address: _____

Contact person: _____

Phone #: _____ Fax #: _____

Email: _____

Purchase Order #: _____

Model #: _____ Serial #: _____

Model #: _____ Serial #: _____

Shipping method to Tesla™: _____

Description of shipping package: _____

Description of problem: _____

Return to Tesla™ Industries, Inc.

101 Centerpoint Boulevard, New Castle, DE 19720 Attention: Repair Department



WE GET THE MILITARY STARTED!

Tesla™ Industries, Inc.

101 Centerpoint Blvd.
New Castle, DE 19720 USA
Tel: 302-324-8910
Fax: 302-324-8912

9475 Double R Blvd., Suite 2
Reno, NV 89521
Tel: 775-622-8801
Fax: 775-622-8810

www.teslaind.com