



TI50A DC Power Supply Battery Charger / Conditioner

Power Anytime, Anywhere



Features

- Perfect for testing and troubleshooting (avionics, TMDE, electronics, and hydraulics)
- Charges and conditions vehicle batteries when unit is left connected to vehicle
- Ideal for hangars, FOBs, motor pools, and deployments
- Operates with circuit breakers, therefore eliminating the need to replace blown fuses
- Safe, easy, maintenance-free operation
- 2-year warranty (3-years optional)

Safe and Easy Operation

- One person can maneuver and operate the unit
- Safe for flight and travel, non-hazardous
- "Available Power" feature provides instant state of power

Pure Power

- Operates from 100-260 Vac power 50/60 Hz
- 50 amps continuous @28.5 Vdc (when plugged into ac power)

Tesla™ Industries, Inc.

www.teslainsd.com

Email: tesla1@teslainsd.com

Headquarters: (302) 324-8910

101 Centerpoint Blvd. New Castle, DE 19720 USA

Western Regional Office: (775) 622-8801

9475 Double R Blvd. Suite 2, Reno, NV 89521 USA



The POWER
Of
RED™



Technical Specifications, Configurations and Options

Technical Specifications:

DC Output	50 amps continuous @ 28.5 Vdc (plugged into ac power)
AC Input Power	<ul style="list-style-type: none">• Operates from Single Phase 100-260 Vac, 50/60 Hz• 10 amps @ 120 Vac 60 Hz - 1200 Watts• 5 amps @ 240 Vac 60 Hz - 1200 Watts
Vibration	Exceeds MIL-STD-810F
Storage Temperature	-65 °C to 105 °C (-85 °F to 221 °F)
Operating Temperature w/ AC Power	-40 °C to 55 °C (-40 °F to 131 °F)
Dimensions	20.61" L x 5.2" W x 10.56" H 523.49 mm x 132.08 mm x 268.25 mm
Weight	15.85 lbs (7.19 kg)
Warranty	2 years (3 years optional)

Includes:



A 8ft. DC Aviation Cable **or**
a 15ft DC NATO Cable Assembly



A North American AC Line Cord

Optional Accessories:



TI7000-024
TI50A Shipping Case
NSN: 6140-01-467-5710



TI7000-046
TI50A Protective Cover



TI7000-184
TI50A Transporting Dolly



Power Anytime, Anywhere

Tesla™ TI50A

DC Power Supply

User Manual



Built Smart...Proven Tough

Tesla Industries, Inc.
101 Centerpoint Blvd.
New Castle, DE 19720
(302) 324-8910 Phone
(302) 324-8912 Fax
www.teslaind.com

**NOTE: All users must read this entire manual prior
to operating the TI50A DC Power Supply.**

The TI50A DC Power Supply is a limited maintenance-free and sealed unit. No repairs are authorized. Warranty will be voided if unit is tampered with in any way, or if unauthorized repairs are made. For technical support please contact:

TESLA™ INDUSTRIES INCORPORATED

101 CENTERPOINT BLVD.
CENTERPOINT INDUSTRIAL PARK
NEW CASTLE, DELAWARE 19720

PHONE: (302) 324-8910

FAX: (302) 324-8912

WEBSITE: www.teslaind.com

EMAIL: tesla1@teslaind.com



CAUTION

Shock Hazard Potential

Improper use or failure to follow instructions in this user manual can result in unit damage and/or injury or death by electrical shock.

Any attempts to open or examine the inside of the TI50A DC Power Supply via a tool or device (borescope, probe, etc.) can result in unit failure and/or injury by electrical shock. This unit is maintenance free and should not be opened or disassembled for any reason.

Always protect the unit from short circuit.

Shipping Hazards: None.

No part of this manual may be reproduced or transmitted in any form or by any means, electronic or mechanical, including photocopying, recording, or any information storage and retrieval system, without prior written permission from Tesla™ Industries, Inc.



NOTE

Unit is not rated for engine starting.
It is to be used for ground maintenance only.

Copyright © 2014 by Tesla™ Industries, Incorporated. All rights reserved.

Table of Contents

Section 1 – Safety Review	1
1.1 – Safety Notices	1
1.2 – Symbols	1
1.3 – Hazards	2
1.4 – Important Safety Precautions	3
1.5 – Extreme Environments	3
Section 2 – Product Overview	4
2.1 – Introduction	4
2.2 – Indication of Terms: Shall, Should, and May	4
2.3 – Front Panel Overview	5
2.4 – General Specifications	6
2.5 – Physical Dimensions	7
2.6 – Airflow Ports	7
2.7 – Operating Position	8
2.8 – AC Input Circuit Breakers	9
2.9 – 24 Vdc Output Connector	9
2.10 – DC Output Circuit Breaker	9
2.11 – Input Voltage Selector Switch	10
2.12 – AC Input Receptacle	11
2.13 – “Available Power” LED Indicator	11
Section 3 – Operating Procedures	12
3.1 – Operating Procedures	12
3.1 – General	12
3.2 – Operating Limits and Restrictions	12
3.4 – Environmental	13
3.5 – Normal Functional Test Procedures	14-15
3.6 – Pre-Operation	16
3.7 – Transporting Unit	16
3.8 – Regulated 28.5 Vdc Ground Power	18

Section 4 – Post Operation	18
4.1 – General	18
4.2 – After Use	18
Section 5 – Unit Care and Maintenance	19
5.1 – Unit Care	19
5.2 – Unit Servicing	20
5.3 – Packaging and Shipping	20
Section 6 – Troubleshooting and FAQ	21
6.1 – Frequently Asked Questions	21-22
6.2 – Basic Usage/Operation Questions	22
6.3 – Basic Troubleshooting	23
Section 7 – Optional Accessories	24
7.1 – Shipping Case	24
7.2 – Protective Covers	24
7.3 – Tesla™ AC Line Cords	24
7.4 – Cobra™ DC Replacement Contacts and Tools	25
7.5 – Transport Dolly	25
Appendix A	26-30
Repair Request Form	31

Abbreviations and Symbols

Abbreviations that may be used within the text, headings and titles of this manual.

LIST OF ABBREVIATIONS



Abbreviation **Definition**

ac	Alternating Current
AFT	Airflow Technology
AWG	American Wire Gauge
amp or A	Ampere
cont	Continuous
°C	Degree Celsius
°F	Degree Fahrenheit
dc	Direct Current
EFF	Efficiency
ft	Feet
FWD	Forward
GPU	Ground Power Unit
Hr	Hour
Hz	Hertz
kg	Kilograms
kHz	Kilohertz
kW	Kilowatts
LED	Light Emitting Diode
max	Maximum
MΩ	megaohm
min	Minimum
MPU	Micro Power Unit
NEMA	National Electrical Manufacturers Association
Ω	ohm
PF	power factor
PFC	power factor correction
rms	root-mean-square
THD	Total Harmonic Distortion
TMDE	Test, Measurement, & Diagnostic Equipment
UAV	Unmanned aerial vehicle
Vac	Volts, Alternating Current
Vdc	Volts, Direct Current
W	watts

Section 1 – Safety Review

1.1 - Safety Notices

Safety notices appear throughout this manual to alert the user to important information regarding proper installation, operation, maintenance and storage of the unit. These notices, as illustrated below, contain a key word that indicates the level of hazard and a triangular icon that indicates the specific type of hazard.

 WARNING	Indicates a condition, operating procedure or practice, which if not adhered to could result in serious injury or death.
 CAUTION	Indicates a condition or operating procedure, which if not strictly adhered to could result in damage or destruction of equipment.
 NOTE	Indicates a condition, operating procedure or practice, which is essential to highlight.

1.2 - Symbols

The following symbols will appear within the warning triangles to alert the user to the specific type of danger or hazard.



Figure 1.2.1 – Different types of hazard and caution symbols

1.3 – Hazards

 **WARNING** Shock Hazard Potential

Severe injury or death from electrical shock may occur if either the user or the unit is wet while the operating unit is connected to a power source. Be sure to disconnect ac power from the ac source if the unit has come into contact with water. If AC Input Circuit Breaker has tripped due to water infiltration, DO NOT try to reset it with the ac line voltage attached.



 **WARNING** Shock Hazard Potential

Severe injury or death from electrical shock can occur when damp electrical plugs are connected to the unit. Make sure the unit is turned off before making any connections. Failure to use proper grounding can cause potential shock hazard! In different countries, the power cord may require the use of a plug adapter to achieve plug style compatibility for operation. Use only adapters with proper grounding mechanism.

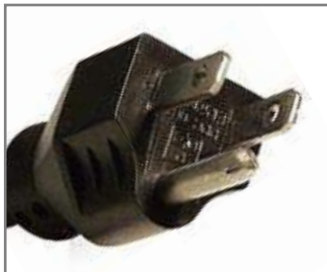

Figure 1.3.1 – Proper Ground Grounded Plug with Grounding Pin



Figure 1.3.2 – Proper Ground Adapter with Grounding Mechanism (Secured to Outlet)



Figure 1.3.3 – Improper Ground Plug with No Grounding Pin

 **CAUTION** Unit Damage Potential

The unit will be damaged if unapproved ac power is applied. Check the Input Voltage Selector Switch window (outlined in blue) to ensure the switch setting (115V or 230V) matches the ac power source (hangar wall, flight line ac power) prior to connecting the unit for recharging.



Figure 1.3.4 – TI50A DC Power Supply Input Voltage Selector Switch

1.4 – Important Safety Precautions



WARNING

Fire/Explosion Hazard Potential

Severe injury or death from fire or explosion can occur if electrical sparks are produced near fuel vapors. DO NOT CONNECT ac power supply WHILE FUELING. AC power functions of unit shall not be operated during any fuel handling operation. Power output is restricted to dc power only.

1.5 – Extreme Environments



CAUTION

Unit Damage Potential

The unit is equipped with a charger temperature switch that automatically disables the unit when the internal temperature exceeds 150 °F (65 °C). This protects the unit from overheating and damage. If the unit shuts down, move the unit into a cooler environment such as shade or air conditioning when possible. Perform a full function test after the unit has been allowed to cool prior to use.

Section 2 – Product Overview

2.1 – Introduction

Thank you and congratulations on the purchase of your new TI50A DC Power Supply.

The TI50A DC Power Supply is intended to provide dc electrical ground power for aircraft flight line and maintenance ground support operations. The unit is designed to provide 28.5 volts dc electrical support for ground maintenance, avionics/electrical troubleshooting and testing. The observance of procedures, limitations and performance criteria is essential to ensure peak operating efficiency and to maximize operational capabilities and life of the TI50A DC Power Supply.

This manual contains the complete operating instructions and procedures for the TI50A DC Power Supply that the end user will need to safely and efficiently operate this DC Power Supply.



Figure 2.1.1 – TI50A DC Power Supply

2.2 – Indication of Terms: Shall, Should, and May

Within this technical manual the word “shall” is used to indicate a mandatory requirement for proper operation and warranty purposes. The word “should” is used to indicate a non-mandatory but preferred method of accomplishment. The word “may” is used to indicate an acceptable method of accomplishment.

2.3 – Front Panel Overview



1. **24 Vdc Output Connector** – Provides 50 amps continuous @ 28.5 Vdc (when plugged into ac power)
2. **Output Connector Protective Cover** - Protects Output Connector from dust and foreign materials.
3. **Air Intake Ports** – Provide airflow for cooling internal electronics.
4. **Carrying Handle** – Allows for easy transport of unit.
5. **AC Input Circuit Breakers** – Trip if over-current fault condition occurs.
6. **“Available Power” Meter** – Displays status of power output.
7. **AC Input Connector** – Connects to Single Phase 100-260 Vac line voltage.
8. **Input Voltage Selector Switch** – Allows unit to operate within voltage range of either 100-130 Vac or 200-260 Vac.
9. **DC Output Breakers** - Trips if an over-current condition occurs.

2.4 – General Specifications

Electrical

AC Input Power:

- Operates from Single Phase 100-260 Vac, 50/60 Hz
- 20 amps @ 120 Vac 60 Hz - 2400 Watts
- 10 amps @ 240 Vac 60 Hz - 2400 Watts

DC Output Power:

- 50 amps continuous @ 28.5 Vdc - 1425 Watts

Size:

- 21.25" long x 5.2" wide x 10.56" high
- 539.7mm x 132.1mm x 268.25mm

Weight

- 15.85 lbs (7.19 kg)

Operating Temperature:

- -40°C to +55°C (-40°F to 131°F) with AC power

Storage Temperature:

- -65°C to +105°C (-85°F to 221°F)

2.5 – Physical Dimensions

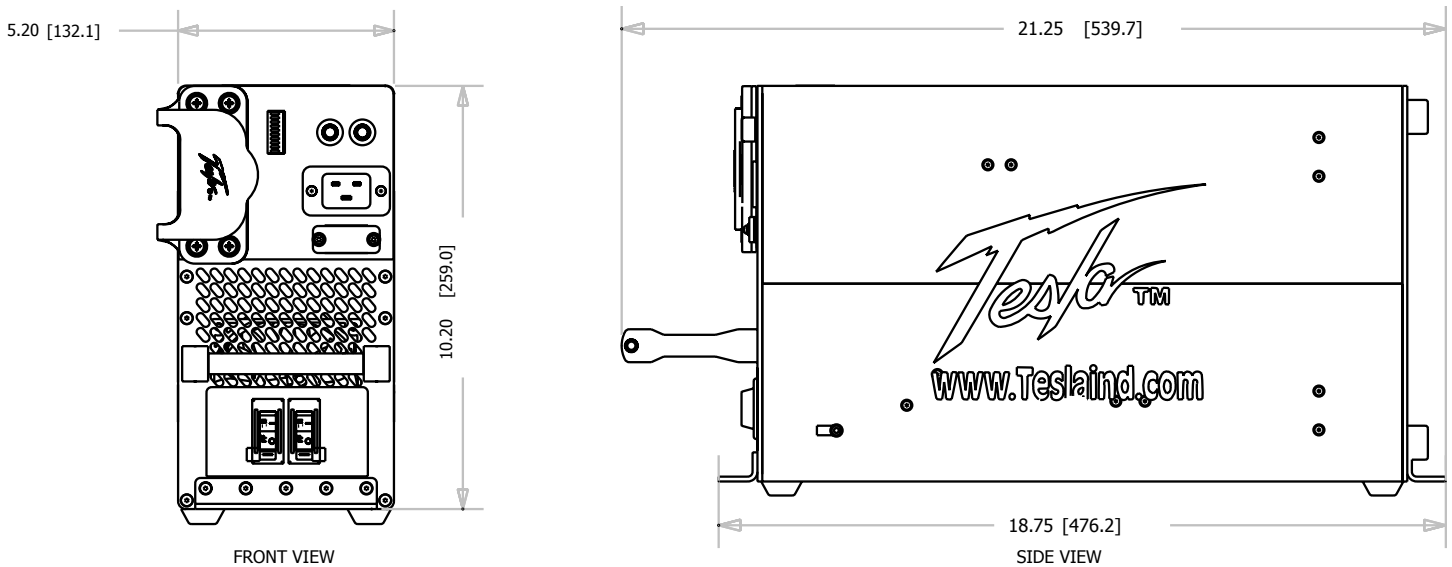

Figure 2.5.1 – TI50A DC Power Supply Physical Dimensions

2.6 – Airflow Ports



CAUTION

Damage may occur if the TI50A DC Power Supply's air intake or outlet ports are obstructed. Ensure that ports are clear at all times.

When the TI50A DC Power Supply is plugged into ac power, the internal cooling system will efficiently regulate unit temperature regardless of load. At room temperature (+77 °F) the exhaust air will not exceed the ambient temperature by more than 5 °F. In more extreme temperatures (greater than 90 °F) the exhaust air will not exceed the ambient temperature by more than 10 °F.

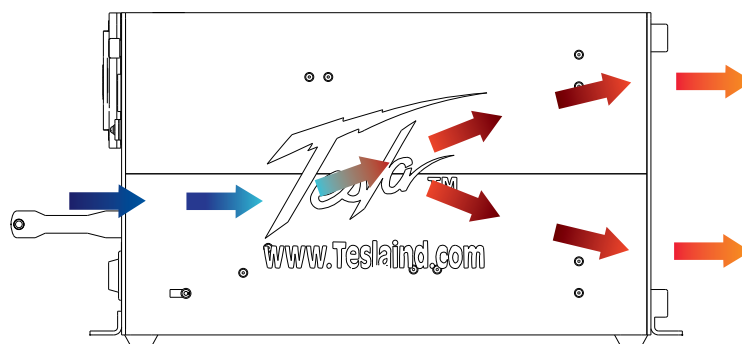
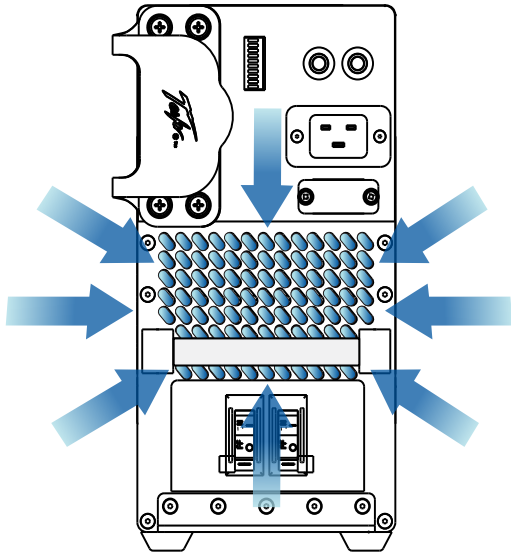

Figure 2.6.1 – Air intake, exhaust ports and internal air circulation

2.7 – Operating Positions

The TI50A DC Power Supply can be operated in both the horizontal and vertical positions as shown. Make sure that the airflow is not obstructed from air intake and outlet.



Front Inlet

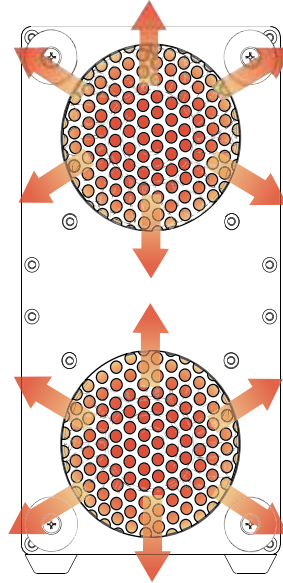

Rear Outlet

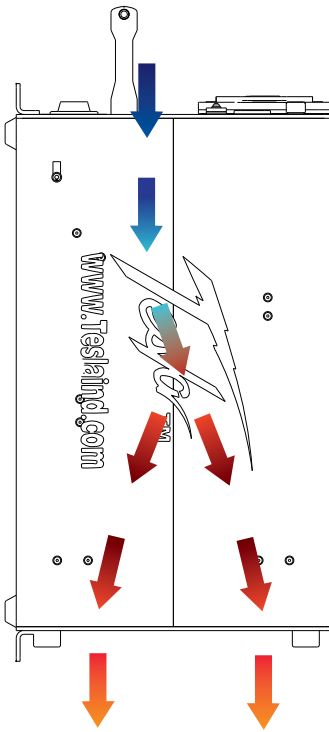

Vertical Position

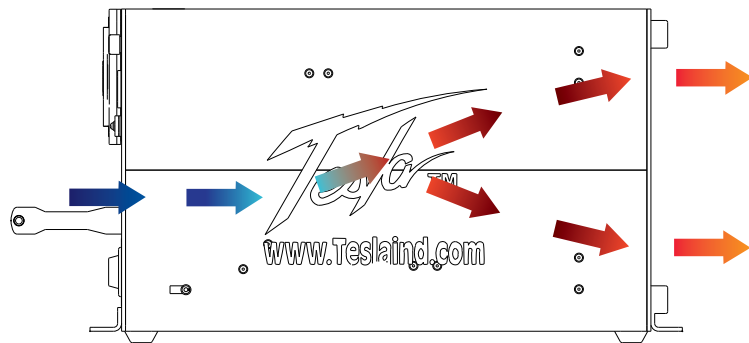

Horizontal Position

2.8 – AC Input Circuit Breaker

The AC input circuit breaker is located above the ac Input Connector. When the circuit breaker has been tripped, the red button will pop out. In the event that the breaker trips:

1. Disconnect the ac and dc connectors. (Unplug ac line cord on military unit.)
2. Wait for a minimum of 60 seconds.
3. Reset breaker by pressing red button.
4. Reconnect ac and dc connections to the unit. (Plug in ac line cord on military unit.)

The unit should power up automatically. If the breaker continues to trip, return the unit to Tesla™ Industries for repair.



Figure 2.8.1 - AC Input Circuit Breaker (outlined in blue)

2.9 – 24 Vdc Output Connector

The 24 Vdc Output Connector will provide 50 amps continuous @ 28.5 Vdc (when plugged into ac power). When the Output Connector is not in use, cover the receptacle with the Protective Cover (see Figure 2.9.1). This will protect the Output Connector from dust and foreign matter.

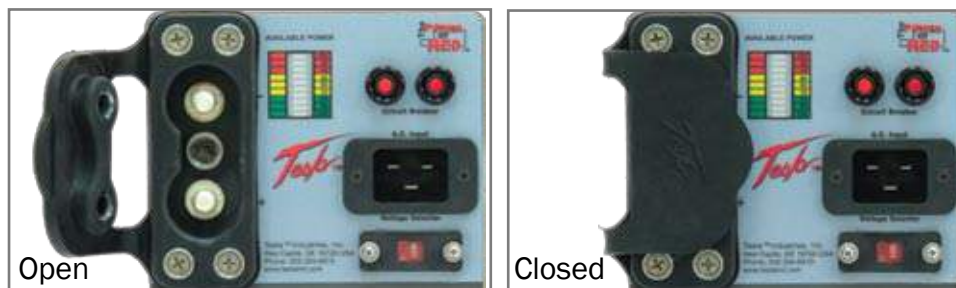

Figure 2.9.1 - 24 Vdc Output Connector Protective Cover

2.10 – DC Output Circuit Breaker

The DC Output Circuit Breaker is located on the bottom section on the front panel. Both Circuit Breakers on together provides 70 Amps max. When the circuit breaker has been tripped, the rocker switch will flip off. If the Circuit Breakers trip, it has exceeded the 70 amps max limit.

If the breaker has tripped:

1. Lower the amperage the unit is pulling below 70 amps.
2. If you are certain your load is below 70 amps and the Circuit Breakers continue to trip, return the unit to Tesla™ for repair.



2.11 – Input Voltage Selector Switch

The Input Voltage Selector Switch allows the unit to operate safely within the expected voltage range of either 100 - 130 Vac or 200 - 260 Vac.



Figure 2.11.1 Input Voltage Selector Switch (outlined in blue)

Changing Input Voltage Selector Switch

To change the input voltage from 115 Vac to 230 Vac, simply follow these steps:

1. With cross tip screwdriver, remove one screw and rotate the clear protective cover to one side. (see figure 2.11.2)
2. Flip the switch to read 230V. (see figure 2.11.3)
3. Rotate cover back into place. Replace and tighten screw.



CAUTION

Do not plug unit into 230 Vac when Input Voltage Selector Switch is set on 115 Vac.



NOTE

The 115 Vac setting accommodates the voltage range of 100-130 Vac. The 230 Vac setting accommodates the voltage range of 200-260 Vac.



Figure 2.11.2 - Unscrew Protective Cover



Figure 2.11.3 - Select Voltage



NOTE

Do not overtighten Selector Shield screws. Be sure star locks are on screws and snug the screw. Overtightening will damage the Selector Shield.

2.12 – AC Input Receptacle

The AC Input Receptacle is designed to plug into either a standard 120 or 240 Vac outlet with the supplied line cord (see Figure 2.10.2. and see also Section 8.3 for the proper line cord for your country and region). Please ensure that the unit is properly grounded at all times (see Section 1.3 for proper grounding techniques).



Figure 2.12.1 - AC Input Receptacle location (outlined in blue)



Figure 2.12.2 AC North American Line Cord

2.13 – “Available Power” LED Indicator

The “Available Power” LED Indicator provides a way for the user to visually see the amount of current load that the TI50A is supplying. This lets the operator know if the maximum current load is being exceeded.

Current loads up to 50 amps will show one or two green bars. If the red bars are illuminated, the unit is supplying less than 24 Vdc. Reduce current load to prevent damage to the unit.



Figure 2.13.1 - “Available Power” LED Indicator location (outlined in blue)

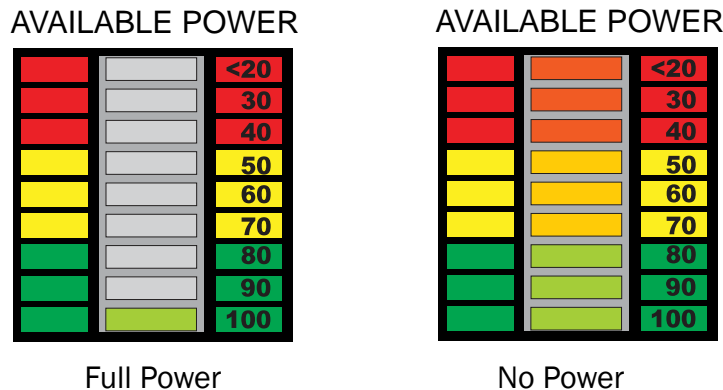

Figure 2.13.2 - “Available Power” LED Indicating power status

Section 3 – Operating Procedures

3.1 – Operating Procedures

This section deals with normal procedures, and includes all steps necessary to ensure safe and efficient operation of the unit.



NOTE

If current demand exceeds 50 amps, power supply voltage will drop below 28.5 Vdc and two or more LED status indicator bars will illuminate. If all LED status indicator bars illuminate, the converter is supplying 24 Vdc power output.

3.2 – General

Correct operation of the unit includes both pre-use and operational checks of the unit. Knowledge of the operating limits, restrictions, performance, unit capabilities and functions is fundamental to correct and safe operation. The operator shall ensure compliance with the instructions in this manual that affect operational safety and the warranty of the unit.

3.3 – Operating Limits and Restrictions

The minimum, maximum and normal operating ranges result from careful engineering and evaluation of test data. These limitations must be adhered to during all phases of operation.

3.4 – Environmental

**WARNING**

Operating any electrical equipment in the presence of moisture creates possible safety hazards and/or potential for equipment damage. Every effort has been made, within the scope of existing technology to prevent foreseeable safety hazards and make the unit moisture resistant to prevent damage or failure.

If the unit is exposed to moisture, preventive measures and precautions shall be taken to:

- A. Prevent accumulation of moisture on ac and dc connectors/receptacles
- B. Minimize moisture entering forward inlet and aft outlet cooling fan vent ports

Unit inlet and outlet vent ports shall be covered from exposure. Unit shall be kept horizontal. It is recommended that the Tesla™ Protective Rain Cover be fitted onto the unit to guard it from moisture (see Section 8). The limits and operational constraints listed below shall apply for the following environmental (weather) conditions:

Conditions	With Raincover	Without Raincover
Heavy or steady rain: <i>Precipitation falling with an intensity in excess of 0.30 inch (0.76 cm) or continuously between 0.30 and 0.10 inch per hour.</i>	OK	OPERATION NOT RECOMMENDED
Light rain, drizzle or sleet: <i>Precipitation falling on a continuous basis between 0.10 inch and less than 1/50 inch (0.5 mm) per hour</i>	OK	DC OPERATIONS ONLY
Heavy or steady snow: <i>Generally meaning an accumulation between 4 inches and less than 1 inch in a 12 hour period.</i>	OK	OPERATION NOT RECOMMENDED
Light snow: <i>Snow falling intermediately with little or no accumulation.</i>	OK	DC OPERATIONS ONLY
Fog:	OK	OK



Figure 3.4.1 – Unit with raincover. Ordering info on page 24.

3.5 – Normal Function Test Procedures

This section deals with “normal function” test procedures, and includes all steps necessary to ensure that the unit is operating within specified parameters prior to use. A digital multimeter (an example is shown in Figure 3.5.1) capable of measuring dc and ac voltage and resistance will be required to perform some of the tests. These functional test procedures should become routine.



Figure 3.5.1 – Digital Multimeter

Check Unit for Evidence of Damage

Check for dents, punctures, case distortion or misalignment, and cracked or loose connectors. If no damage is evident, proceed to the next step. If damage is evident, contact Tesla™ Industries, Inc.

Check DC Voltage Reading at DC Receptacle Terminals

To verify that the power supply is functioning normally, set the digital multimeter to measure dc voltage. Turn the unit on. Turn on both DC Output Circuit Breakers (Figure 3.6.2). As shown in Figure 3.6.3, place the positive probe (red) on the positive post of the dc output connector and the negative probe on the negative post. The multimeter display should read approximately 28.5 Vdc (± 0.5 Vdc). NOTE: To test each Circuit Breaker individually, turn only one of the Circuit Breakers on at a time when testing. As in the previous test, the multimeter display should read approximately 28.5 Vdc (± 0.5 Vdc).



Figure 3.5.2 – DC Output Circuit Breakers has a 70 amps max



Figure 3.5.3 – Testing DC Receptacle

Check Unit Internal Resistance (Test for Shorts)

**NOTE**

Unit should be disconnected from any ac power sources prior to testing.



1. Set multimeter to Ohms.



2. Turn on both DC Circuit Breakers before testing.



3. Place the negative probe on the ac ground post and the positive probe to the dc positive post. Multimeter should read greater than 10 MΩ.



4. Move the positive probe to the dc negative post. Multimeter should read greater than 10 MΩ.



5. Move the positive probe to the fastener screw on the dc receptacle. Multimeter should read less than 1Ω.



1. Set multimeter to Volts.



2. Place the positive probe to the fastener screw on the dc receptacle. Move the negative probe to the dc negative post. Multimeter should read 0 Volts.



3. Place the negative probe to the fastener screw on the dc receptacle. Move the positive probe to the dc positive post. Multimeter should read 0 Volts.

3.6 – Pre-Operation

1. Be sure to check that all input and output cables are not damaged. (See Section 5.1)
2. Check unit carefully for any evidence of damage.
3. Make sure that airflow is not obstructed from air intake and outlet. (See Section 2.6)
4. Check that all connections are secure and free from water.
5. Prior to connecting the TI50A to an ac power source, be sure that the charger is at least 20 feet away from any fuel source to avoid a potential explosion due to sparking.



Figure 3.6.1 - TI50A DC Power Supply

The TI50A DC Power Supply is engineered to provide continuous output power. Thus, the charger can be left connected to a battery until it is ready for use. This is due to the intelligent recharging system that prevents the TI50A from overcharging the battery.

3.7 – Transporting Unit

The TI50A DC Power Supply can be carried for short distances by hand, but if the area of operation is further than 45 meters (150 feet) it is recommended that the TI50A DC Power Supply should be transported on a vehicle or in the TI7000-184 Transport Dolly (see Section 7 Optional Accessories).

TI7000-184 Transport Dolly Dimensions:

16.87" L x 14.5" W x 49.25" H

428.50 mm x 368.30 mm x 1250.95 mm

Weight:

18.5 lbs (8.39 kg)



Figure 3.8.1 TI7000-184 Transport Dolly

**NOTE**

Unit is not rated for engine starting. It is to be used for ground maintenance only.

3.8 – Regulated 28.5 Vdc Ground Power**NOTE**

Turn off DC Circuit Breakers before attaching cable to unit. Turn on DC Circuit Breakers after both ends of the DC Power Cable has been connected.

Connecting DC Power Cable To Unit

Line up the dc plug with the receptacle. Push forward while rotating the T-handle one full turn clockwise. Ensure dc power cable plug is fully seated into the unit's DC Battery Receptacle. The unit is now ready to safely transfer power.



Figure 3.8.1 Attaching DC Power Cable to TI50A DC Power Supply

Connecting DC Power Cable To Vehicle or Aircraft

Line up the NATO plug or Aviation dc plug pins and push it in. DC bus power should come on and aircraft voltmeter should indicate 24 Vdc to 23.5 Vdc (23 Vdc minimum). Ensure DC power cable plug is fully seated into the vehicle or aircraft's dc receptacle.



Figure 3.8.2 Attaching NATO DC Power Cable to vehicle



Figure 3.8.3 Attaching an Aviation DC Power Cable to aircraft

Low Power Demand

Low power demand is defined by a requirement of 50 amps or less. Connect dc power to vehicle or aircraft ground power receptacle. DC bus power should come on and vehicle or aircraft voltmeter should indicate 28.5 Vdc to 27 Vdc (26.5 Vdc minimum). If vehicle or aircraft power demand is less than 50 amps converter output will remain at 28.5 Vdc (only one GREEN LED status indicator bar will illuminate). If vehicle or aircraft power demand exceeds 50 amps converter voltage output will decrease and two or more LED status indicator bars will illuminate.

Section 4 – Post Operation

4.1 – General

Although the TI50A DC Power Supply has been ruggedized and made weather resistant within the scope of unit's intended use, it is essential that good general care be taken to maintain unit in good operating condition and to maximize unit's operational life.

4.2 – After Use

Unit should be protected from environmental elements and man made hazards. Ideally unit should be secured in a building or shed. Most importantly, unit shall be fully covered if stored while exposed to environmental elements. Do not expose to wet or dusty environments (rain, snow, sand, etc.) as this may damage internal circuitry. See Section 3.4 for more information concerning water infiltration.

Section 5 – Unit Care and Maintenance



WARNING

Severe injury or death from electrical shock may occur if either the user or the unit is wet while operating the unit with an ac power source attached.



CAUTION

Damage may occur if an unapproved or modified ac line cable or input plug is attached to the unit. Do not use any type of ac voltage converter.

5.1 - Unit Care

Avoid Prolonged Exposure to Extremely Damp Environments

Be sure to disconnect ac power from the ac source if the unit has come into contact with water. If the AC Input Circuit Breaker has tripped due to water infiltration, allow the unit to dry out before attempting to reset circuit breaker. Cover the unit to prevent water seepage. If the unit is operated in extremely damp conditions, it should be stored in an environmentally controlled building when not in use. Wipe unit clean periodically with a soft cloth to remove dust, dirt, etc.



Protect Cables from Damage

Do not cut, crush, or drag the input or output power cables when handling the unit. Always inspect cables prior to use. If no damage is evident, proceed to the next step. If damage is evident, contact Tesla™ Customer Service. Do not attempt to use any other type of power cables other than the Tesla™ cables included with the unit.



Figure 5.1.1 – Damaged cable

5.2 – Unit Servicing

The TI50A DC Power Supply is a maintenance-free, sealed unit. No repairs outside of Tesla™ are authorized. Warranty will be voided if unit is tampered with in any way including any damage to the WARRANTY VOID stickers located on the case (see Figure 5.2.1 below). If the unit requires maintenance, please contact Tesla™ Customer Service at (302) 324-8910. A Repair Request Form can be found in the back of this manual.

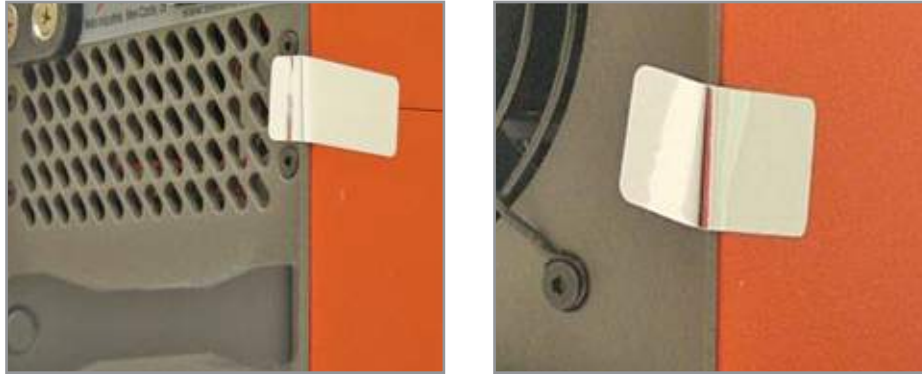

Figure 5.2.1 – Warranty Void stickers Front and Back on the TI50A DC Power Supply

5.3 – Packaging and Shipping

When returning the DC Power Supply, please ensure that it is properly packaged. The only method for transport is in a sturdy shipping crate or Tesla™ Shipping Case (be sure to enclose the Repair Request Form located on the last page of this manual). Seal the crate on all sides and return it to Tesla™ at the address listed below. Please contact Tesla™ Customer Service at (302) 324-8910 with any questions or concerns.

TESLA™ INDUSTRIES, INCORPORATED
101 CENTERPOINT BLVD.
CENTERPOINT INDUSTRIAL PARK
NEW CASTLE, DELAWARE 19720
PHONE: (302) 324-8910 FAX: (302) 324-8912
Website: www.teslaind.com Email: Tesla1@teslaind.com



Figure 5.3.1 – Tesla Industries Shipping Case

Section 6 – Troubleshooting and FAQ

6.1 – Frequently Asked Questions

1. How does a Tesla™ TI50A DC Power Supply work?

The Tesla™ TI50A DC Power Supply incorporates an intelligent charging system with a pure dc output that allows it to rapidly charge and condition a battery without overcharging or damaging it.

2. How much DC power will the TI50A DC Power Supply provide?

The TI50A DC Power Supply will provide up to 50 continuous amps @ 28.5 Vdc.

3. How long will it take to charge my battery?

Battery charge time can be determined by taking the battery's rated amp hours and dividing this number by the TI50A's maximum output current. For example, a 24 V / 50 Ah battery will take one hour to charge using a TI50A DC Power Supply.

4. What is included with my TI50A DC Power Supply?

The DC Power Supply comes with a Tesla™ approved 8ft. DC Aviation Cable Assembly or a 15ft. DC NATO Cable Assembly, a North American line cord, a user manual, and a limited two-year warranty.

5. Is the TI50A Series DC Power Supply waterproof?

The TI50A DC Power Supply is NOT waterproof. See Section 5.1 for further information regarding safe operation in damp environments.

6. Are there any HAZMAT or disposal issues?

No. Contact Tesla™ for more information.

7. Are Tesla™ DC Power Supply used in shop maintenance and testing?

Tesla systems are gaining popularity throughout maintenance facilities, instructional facilities, laboratories, manufacturing plants, aircraft hangars and many other locations. The reason is due to the precise flat line dc power, the small, portable and quiet nature of our systems and the maintenance free aspect of our DC Power Supply's. We can custom tailor ground power systems to fit your individual requirements.

8. Can one person transport it?

The TI50A is designed to be handled by one person. The TI50A DC Power Supply system weighs 15.85 lbs.

9. How do I get my DC Power Supply serviced?

Contact Tesla. We can be reached at (302) 324-8910. Ask for customer service. You can also email us at tesla1@teslaind.com. Once we receive the unit at our facility, we will examine it. Systems that are protected under warranty will be repaired at no charge. If the warranty has expired, you will receive a quote for necessary repairs prior to work being done. Our turnaround time is 48 hours once repairs are authorized.

10. Can I make my own repairs to unit?

During the warranty period, the unit can only be repaired by Tesla Industries for the warranty to remain in effect. Regardless, we strongly recommend allowing Tesla to repair any unit as we will analyze the complete system and re-calibrate it.

11. What type of maintenance does the DC Power Supply require?

Although the systems are maintenance free, please keep the vent areas clean and free of debris. Keep units in a well ventilated area. Keep the unit in a protected environment when not in use (maintenance facility, shed).

6.2 - Basic Usage/Operation Questions

1. What's the best position to place the unit for use vertical or horizontal?

Preferred position is horizontal for stability and airflow considerations.

2. How do I check the status of the Available Power?

The "Available Power" LED Indicator provides a way for the user to visually see the amount of available power that the TI50A can supply. This lets the operator know if there is enough power to perform ground maintenance. For more information see Section 2.12.

3. Why is the cooling fan always running when I am plugged into AC power?

Constant cooling fan operation ensures proper and consistent ventilation of the unit.

4. Why does the cooling fan slow down?

Cooling fan rpm varies for better temperature regulation.

5. What do I do if a circuit breaker trips?

The AC input circuit breakers are located above the AC Input Connector. When the circuit breaker has been tripped, either of the red buttons will pop out. In the event that the breaker trips:

1. Disconnect the ac and dc connectors. (Unplug ac line cord on military unit.)
2. Wait for a minimum of 60 seconds.
3. Reset breaker(s) by pressing red button(s).
4. Reconnect ac and dc connections to the unit. (Plug in ac line cord on military unit.)

The unit should power up automatically. If the breaker continues to trip, return the unit to Tesla Industries for repair.

6.3 - Basic Unit Troubleshooting

Fault	Possible Cause	Remedy
1. Output Capacity LED does not come on.	<ul style="list-style-type: none"> A. Circuit Breaker has tripped. B. No outlet power. 	<ul style="list-style-type: none"> A. Plug the unit in to the appropriate ac power outlet. B. If LEDs still do not illuminate, C. Please contact Tesla™ Customer Service at (302) 324-8910
2. Unit will not power from ac outlet.	<ul style="list-style-type: none"> A. AC line cord is damaged or bad. B. Is ac line cord fully plugged into unit and wall outlet. C. AC circuit breaker has been tripped. D. No ac power at outlet. 	<ul style="list-style-type: none"> A. Do a continuity test on the ac line cord B. Check if line cord is properly secured. C. Check to make sure ac circuit breaker is placed in the “ON” position.
3. Unit failed function test.	<ul style="list-style-type: none"> A. Internal failure. 	<ul style="list-style-type: none"> A. Please contact Tesla™ Customer Service at (302) 324-8910
4. Unit emits sparks when plugged into power source.	<ul style="list-style-type: none"> A. Water or moisture has seeped in unit B. Internal failure. 	<ul style="list-style-type: none"> A. Move unit to dry warm air and allow to dry for over 48 hours. B. Do Not Use Unit. Please contact Tesla™ Customer Service at (302) 324-8910
5. Unit works then shuts down.	<ul style="list-style-type: none"> A. Unit is overheating. B. Cooling fans and vents are obstructed or inoperable. 	<ul style="list-style-type: none"> A. Move the unit to an area 10°-20° less than ambient temperature. B. Clean and clear cooling vents, turn on unit and inspect if air is flowing through unit. If no airflow please contact Tesla™ Customer Service at (302) 324-8910.
6. Circuit breaker continuously trips	<ul style="list-style-type: none"> A. Unit is overheating. B. Internal Short 	<ul style="list-style-type: none"> A. Disconnect unit from ac input and dc output. B. Switch breaker to ON position. C. Reconnect unit to cables and run. D. If LEDs still do not illuminate, E. Please contact Tesla™ Customer Service at (302) 324-8910

Section 7 – Optional Accessories

7.1 – Shipping Case

The optional Shipping Case is the safest way to transport the TI50A DC Power Supply. This custom case weighs 23 lbs and comes equipped with side handles and locking latches.

TI7000-024

NSN: 8145-01-445-3666

- Length: 24" (609.60 mm)
- Width: 8.50" (215.90 mm)
- Height: 19.50" (495.30 mm)
- Weight: 23 Lbs (10.5 kg)



7.2 – Protective Covers

Protects unit from moisture, sand and other damaging elements. Custom fit for the TI50A DC Power Supply.

TI7000-046



7.3 – Tesla™ AC Line Cords

These power cables come in several lengths or can be custom-ordered to fit your needs. Tesla™ specializes in outfitting cables with a variety of connectors and junction boxes. Contact Tesla™ Customer Service to find out more about our selection of cables.

Regular Line Cords

For units with a fuse and old-style receptacle.

- TI25000-001 North American Line Cord
- TI25000-002 Italian Line Cord
- TI25000-003 Continental European Line Cord
- TI25000-004 Old British Line Cord
- TI25000-005 England / UK Line Cord
- TI25000-006 Swiss Line Cord
- TI25000-011 Australian Line Cord
- TI25000-200 Israel Line Cord
- TI25000-300 Denmark Line Cord

Line Cords

For units with a circuit breaker and new-style receptacle.

- TI25000-211 North American Line Cord
- TI25000-212 Italian Line Cord
- TI25000-213 Continental European Line Cord
- TI25000-214 Old British Line Cord
- TI25000-215 England / UK Line Cord
- TI25000-216 Swiss Line Cord
- TI25000-201 Australian Line Cord
- TI25000-203 Israel Line Cord
- TI25000-304 Denmark Line Cord
- TI25000-032 North American Commercial Line Cord

*To be used for TI3000 Commercial Unit only.



NEMA 515P



Italian



Continental European



Old British



England/UK



Swiss



Australian



Israel



Denmark



NEMA 520P

7.4 – Cobra™ DC Replacement Contacts and Tools

Cobra™ DC Plugs are designed to provide reliable high-power connections up to 3000 amps – even in the harshest conditions. Each plug is constructed from a rugged combination of advanced composite materials and corrosion-resistant alloys to maximize durability and connectivity. To extend the life of the Cobra™ Connector included with your unit, replacement contacts, posts, noses and tools can be ordered through the Tesla™ Customer Service.

TI2005-238

Cobra™ Aviation Plug



TI2005-078

Cobra™ NATO Connector

NSN: 6130-01-523-1270 (CL IX)



TI2005-251

DC Aviation Plug
Positive/Negative
Contact



TI2005-654

DC 400Hz Aviation Plug
Positive/Negative
Contact



TI2004-444

NATO Replacement Post

For newer NATO plugs with new style post, indicated by the black tip. Replacement plug uses standard 3/4" deep well socket for installation.



TI2005-250

DC Aviation Plug
3-slotted Connector



TI2005-239

Aviation Insertion/
Extraction Tool



TI2005-121

NATO Negative Contact

NSN: 5999-01-525-0582 (CL IX)



TI2005-117

NATO Positive Post

NSN: 5935-01-523-8914 (CL IX)



TI2004-341

Replacement Nose for
Aviation Plug



TI2004-340

Replacement Nose for
400Hz Aviation Plug



TI2005-126

NATO Negative Contact
Insertion/Extraction Tool

NSN: 5120-01-523-8761 (CL II)



TI27000-082

NATO Positive Contact
Insertion/Extraction Tool

NSN: 5120-01-527-7729 (CL II)



7.5 – Transport Dolly

The Tesla™ TI7000-184 is a custom aluminum dolly designed especially to transport the Tesla™ TI50A DC Power Supply. The TI7000-184 is the safest and easiest way to support and transport the TI50A models out in the field and through hangars and flight lines. Tesla™ stands behind the Transport Dolly with a team of customer service professionals and a 2-year warranty.

TI7000-184 Transport Dolly Dimensions:
16.87" L x 14.5" W x 49.25" H
428.50 mm x 368.30 mm x 1250.95 mm

Weight:
18.5 lbs (8.39 kg)



APPENDIX A

OPTIONAL LINE CORDS FOR WORLDWIDE OPERATIONS

<u>COUNTRY</u>	<u>VOLTS</u>	<u>HZ</u>	<u>TESLA™ PART #</u>
Afghanistan	220	50	TI25000-004 Old British Line Cord
Algeria	220	50	TI25000-004 Old British Line Cord
American Samoa	240	60	TI25000-011 Australian Line Cord
Angola	220	50	TI25000-003 Continental European Line Cord
Anguilla (U.K.)	240	50	TI25000-005 United Kingdom Line Cord
Antigua	230	60	TI25000-005 United Kingdom Line Cord
Argentina	220	50	TI25000-011 Australian Line Cord
Aruba	115	60	TI25000-001 North American Line Cord
Australia	240	50	TI25000-011 Australian Line Cord
Austria	220	50	TI25000-003 Continental European Line Cord
Azores (Portugal)	220	50	TI25000-004 Old British Line Cord
Bahamas	120	60	TI25000-001 North American Line Cord
Bahrain	220	50	TI25000-005 United Kingdom Line Cord
Bangladesh	220	50	TI25000-004 Old British Line Cord
Barbados	115	50	TI25000-001 North American Line Cord
Belgium	220	50	TI25000-003 Continental European Line Cord
Belize (Br. Hond.)	110	60	TI25000-001 North American Line Cord
Benin	220	50	TI25000-004 Old British Line Cord
Bermuda	120	60	TI25000-005 United Kingdom Line Cord
Bolivia	220	50	TI25000-003 Continental European Line Cord
Botswana	220	50	TI25000-005 United Kingdom Line Cord
Brazil	110	60	TI25000-001 North American Line Cord
Bulgaria	220	50	TI25000-003 Continental European Line Cord
Burkina Faso	220	50	TI25000-003 Continental European Line Cord
Burma (Now Myanmar)	230	50	TI25000-005 United Kingdom Line Cord
Burundi	220	50	TI25000-003 Continental European Line Cord
Cambodia	220	50	TI25000-003 Continental European Line Cord
Cameroon	230	50	TI25000-003 Continental European Line Cord
Canada	120	60	TI25000-001 North American Line Cord
Canary Islands (Spain)	220	50	TI25000-003 Continental European Line Cord
Cape Verde, Rep. of	220	50	TI25000-003 Continental European Line Cord
Cayman Islands	120	60	TI25000-001 North American Line Cord
Central African Republic	220	50	TI25000-003 Continental European Line Cord
Chad	220	50	TI25000-003 Continental European Line Cord
Channel Islands	240	50	TI25000-005 United Kingdom Line Cord
Chile	220	50	TI25000-002 Italian Line Cord
China, Peoples Republic of	220	50	TI25000-011 Australian Line Cord
Christmas Island (Australia)	240	50	TI25000-011 Australian Line Cord
Cocos Islands (Australia)	240	50	TI25000-011 Australian Line Cord
Columbia	220	60	TI25000-003 Continental European Line Cord
Congo, Republic of	220	50	TI25000-003 Continental European Line Cord
Cook Island (New Zealand)	240	50	TI25000-011 Australian Line Cord
Costa Rica	120	60	TI25000-001 North American Line Cord
Curacao Islands	110	60	TI25000-001 North American Line Cord
Cyprus	240	50	TI25000-005 United Kingdom Line Cord
Czech, Republic of	220	50	TI25000-003 Continental European Line Cord
Denmark	220	50	TI25000-300 Denmark Line Cord
Djibouti, Republic of	220	50	TI25000-003 Continental European Line Cord
Dominica	230	50	TI25000-005 United Kingdom Line Cord
Dominican Republic	110	60	TI25000-001 North American Line Cord

APPENDIX A (Cont.)

OPTIONAL LINE CORDS FOR WORLDWIDE OPERATIONS

<u>COUNTRY</u>	<u>VOLTS</u>	<u>HZ</u>	<u>TESLA™ PART #</u>
Ecuador	120	60	TI25000-001 North American Line Cord
Egypt	220	50	TI25000-003 Continental European Line Cord
El Salvador	115	60	TI25000-001 North American Line Cord
England	240	50	TI25000-005 United Kingdom Line Cord
Equatorial Guinea	220	50	TI25000-003 Continental European Line Cord
Estonia	220	50	TI25000-003 Continental European Line Cord
Ethiopia	220	50	TI25000-003 003 Continental European Line Cord
Fiji	240	50	TI25000-011 Australian Line Cord
Finland	220	50	TI25000-003 Continental European Line Cord
France	220	50	TI25000-003 Continental European Line Cord
French Guiana	220	50	TI25000-003 Continental European Line Cord
Gabon	220	50	TI25000-003 Continental European Line Cord
Gambia	220	50	TI25000-005 United Kingdom Line Cord
Georgia	220	50	TI25000-003 Continental European Line Cord
Germany	220	50	TI25000-003 Continental European Line Cord
Ghana	220	50	TI25000-005 United Kingdom Line Cord
Gibraltar	240	50	TI25000-005 United Kingdom Line Cord
Greece	220	50	TI25000-003 Continental European Line Cord
Greenland (Denmark)	220	50	TI25000-300 Denmark Line Cord
Grenada	230	50	TI25000-005 United Kingdom Line Cord
Guadeloupe	220	50	TI25000-003 Continental European Line Cord
Guam	110-120	60	TI25000-001 North American Line Cord
Guatemala	120	60	TI25000-001 North American Line Cord
Guinea	220	50	TI25000-003 Continental European Line Cord
Guinea-Bissau	220	50	TI25000-003 Continental European Line Cord
Guyana	110	50/60	TI25000-001 North American Line Cord
Haiti	110-120	50-60	TI25000-001 North American Line Cord
Honduras	110	60	TI25000-001 North American Line Cord
Hong Kong	220	50	TI25000-005 United Kingdom Line Cord
Hungary	220	50	TI25000-003 Continental European Line Cord
Iceland	220	50	TI25000-003 Continental European Line Cord
India	220-250	50	TI25000-004 Old British Line Cord
Indonesia	220	50	TI25000-003 Continental European Line Cord
Iran	220	50	TI25000-003 Continental European Line Cord
Iraq	220	50	TI25000-005 United Kingdom Line Cord
Ireland, Republic of	220	50	TI25000-005 United Kingdom Line Cord
Isle of Man	240	50	TI25000-005 United Kingdom Line Cord
Israel	230	50	TI25000-200 Israel Line Cord
Italy	220	50	TI25000-002 Italian Line Cord
Ivory Coast	220	50	TI25000-003 Continental European Line Cord
Jamaica	110	50	TI25000-001 North American Line Cord
Japan	110	50/60	TI25000-001 North American Line Cord
Jordan	220	50	TI25000-005 United Kingdom Line Cord
Kenya	240	50	TI25000-005 United Kingdom Line Cord
Korea, South	220	60	TI25000-003 Continental European Line Cord
Kuwait	240	50	TI25000-005 United Kingdom Line Cord

APPENDIX A (Cont.)

OPTIONAL LINE CORDS FOR WORLDWIDE OPERATIONS

<u>COUNTRY</u>	<u>VOLTS</u>	<u>HZ</u>	<u>TESLA™ PART #</u>
Laos	220	50	TI25000-001 North American Line Cord
Latvia	220	50	TI25000-003 Continental European Line Cord
Lebanon	220	50	TI25000-003 Continental European Line Cord
Lesotho	240	50	TI25000-004 Old British Line Cord
Liberia	120	60	TI25000-005 United Kingdom Line Cord
Liechtenstein	220	50	TI25000-006 Switzerland Line Cord
Lithuania	220	50	TI25000-003 Continental European Line Cord
Luxembourg	220	50	TI25000-003 Continental European Line Cord
Libya	230	50	TI25000-002 Italian Line Cord
Macao	220	50	TI25000-004 Old British Line Cord
Madagascar	220	50	TI25000-003 Continental European Line Cord
Maderia (Portugal)	220	50	TI25000-004 Old British Line Cord
Majorca	220	50	TI25000-003 Continental European Line Cord
Malawi	230	50	TI25000-005 United Kingdom Line Cord
Malaysia	240	50	TI25000-005 United Kingdom Line Cord
Maldives	230	50	TI25000-004 Old British Line Cord
Mali, Republic of	220	50	TI25000-003 Continental European Line Cord
Malta	240	50	TI25000-005 United Kingdom Line Cord
Martinique	220	50	TI25000-003 Continental European Line Cord
Mauritania	220	50	TI25000-003 Continental European Line Cord
Mauritius	230	50	TI25000-005 United Kingdom Line Cord
Mexico	127	60	TI25000-001 North American Line Cord
Monaco	220	50	TI25000-003 Continental European Line Cord
Mongolia	220	50	TI25000-003 Continental European Line Cord
Montseurrat	230	60	TI25000-005 United Kingdom Line Cord
Morocco	220	50	TI25000-003 Continental European Line Cord
Mozambique	220	50	TI25000-003 Continental European Line Cord
Namibia (W.S. Africa)	220-250	50	TI25000-004 Old British Line Cord
Nepal	220	50	TI25000-004 Old British Line Cord
Neth. Antilles	220	50/60	TI25000-003 Continental European Line Cord
Netherlands	220	50	TI25000-003 Continental European Line Cord
New Caledonia	220	50	TI25000-003 Continental European Line Cord
New Zealand	230	50	TI25000-011 Australian Line Cord
Nicaragua	120	60	TI25000-001 North American Line Cord
Niger	220	50	TI25000-003 Continental European Line Cord
Nigeria	230	50	TI25000-005 United Kingdom Line Cord
Norfolk Islands (Australia)	240	50	TI25000-011 Australian Line Cord
North Ireland	220	50	TI25000-005 United Kingdom Line Cord
North Mariana Islands (U.S.)	115	60	TI25000-001 North American Line Cord
Norway	220	50	TI25000-003 Continental European Line Cord
Okinawa	100-120	60	TI25000-001 North American Line Cord
Oman	240	50	TI25000-005 United Kingdom Line Cord
Pakistan	230	50	TI25000-004 Old British Line Cord
Panama	110	60	TI25000-001 North American Line Cord
Papua New Guinea	240	50	TI25000-011 Australian Line Cord
Paraguay	220	50	TI25000-003 Continental European Line Cord
Peru	110	50/60	TI25000-001 North American Line Cord
Philippines	115	60	TI25000-001 North American Line Cord
Piccairn Islands (U.K.)	240	50	TI25000-004 Old British Line Cord
Poland	220	50	TI25000-003 Continental European Line Cord
Portugal	220	50	TI25000-003 Continental European Line Cord
Puerto Rico	120	60	TI25000-001 North American Line Cord

APPENDIX A (Cont.)

OPTIONAL LINE CORDS FOR WORLDWIDE OPERATIONS

<u>COUNTRY</u>	<u>VOLTS</u>	<u>HZ</u>	<u>TESLA™ PART #</u>
Romania	220	50	TI25000-003 Continental European Line Cord
Russia	220	50	TI25000-003 Continental European Line Cord
Rwanda	220	50	TI25000-003 Continental European Line Cord
Saudi Arabia	220	50/60	TI25000-003 Continental European Line Cord
Scotland	220	50	TI25000-005 United Kingdom Line Cord
Senegal	220	50	TI25000-003 Continental European Line Cord
Seychelles	240	50	TI25000-005 United Kingdom Line Cord
Sierra Leone	230	50	TI25000-005 United Kingdom Line Cord
Singapore	230	50	TI25000-005 United Kingdom Line Cord
Slovakia	220	50	TI25000-003 Continental European Line Cord
Somalia	220	50	TI25000-003 Continental European Line Cord
South Africa	220-250	50	TI25000-004 Old British Line Cord
Spain	220	50	TI25000-003 Continental European Line Cord
Sri Lanka	230	50	TI25000-004 Old British Line Cord
St. Pierre & Miquelon (France)	115	60	TI25000-001 North American Line Cord
St. Kitts & Nevis	230	60	TI25000-005 United Kingdom Line Cord
St. Lucia	240	50	TI25000-005 United Kingdom Line Cord
St. Vincent	230	50	TI25000-005 United Kingdom Line Cord
Sudan	240	50	TI25000-005 United Kingdom Line Cord
Surinam	115	60	TI25000-003 Continental European Line Cord
Svalbard (Norway)	220	50	TI25000-003 Continental European Line Cord
Swaziland	230	50	TI25000-004 Old British Line Cord
Sweden	220	50	TI25000-003 Continental European Line Cord
Switzerland	220	50	TI25000-006 Switzerland Line Cord
Syria	220	50	TI25000-003 Continental European Line Cord
Tahiti	220	50	TI25000-003 Continental European Line Cord
Taiwan	110	60	TI25000-001 North American Line Cord
Tanzania	230	50	TI25000-005 United Kingdom Line Cord
Thailand	220	50	TI25000-003 Continental European Line Cord
Togo	220	50	TI25000-003 Continental European Line Cord
Tonga	115	60	TI25000-004 Old British Line Cord
Trinidad & Tobago	230	60	TI25000-005 United Kingdom Line Cord
Tunisia	220	50	TI25000-003 Continental European Line Cord
Turkey	220	50	TI25000-003 Continental European Line Cord
Uganda	220	50	TI25000-004 Old British Line Cord
United Arab Emir.	220	50	TI25000-005 United Kingdom Line Cord
United Kingdom & Ireland	240	50	TI25000-005 United Kingdom Line Cord
United States	120	60	TI25000-001 North American Line Cord
Uruguay	220	50	TI25000-011 Australian Line Cord
Venezuela	120	60	TI25000-001 North American Line Cord
Vietnam	220	50	TI25000-003 Continental European Line Cord
Virgin Islands	120	60	TI25000-001 North American Line Cord
Wales	220	50	TI25000-005 United Kingdom Line Cord
Western Samoa	230	50	TI25000-005 United Kingdom Line Cord
Yemen	220	50	TI25000-005 United Kingdom Line Cord
Yugoslavia	220	50	TI25000-003 Continental European Line Cord
Zaire, Republic of	220	50	TI25000-003 Continental European Line Cord
Zambia	220	50	TI25000-005 United Kingdom Line Cord
Zimbabwe	220	50	TI25000-005 United Kingdom Line Cord

APPENDIX A (Cont.)

UNIVERSAL LINE CORD KIT FOR WORLDWIDE OPERATIONS

NOTE: TESLA™ UNIVERSAL AC LINE CORD KIT, P/N: **TI25000-U00**, IS FOR UNITS ORIGINALLY BUILT WITH THE UNIVERSAL AC LINE CORD OPTION ONLY.
THE AC ADAPTER OPTION IS TESLA™ P/N **TI16000-19** AND MUST BE ORDERED WITH THE ORIGINAL PROCUREMENT OF UNIT(S). UNIT(S) MAY BE RETURNED TO TESLA™ INDUSTRIES, FOR A NOMINAL COST, AND MODIFIED TO ALLOW OPERATION WITH THE UNIVERSAL AC LINE CORD KIT.

TESLA™ UNIVERSAL AC LINE CORD KIT, P/N: **TI25000-U00**, IS COMPRISED OF THE FOLLOWING FIVE PART NUMBERS:

TI25000-111	NORTH AMERICAN LINE CORD
TI25000-113	EUROPEAN 10A/250V
TI25000-114	OLD BRITISH LINE CORD
TI25000-115	ENGLAND 10A/250V
TI7000-131	LINE CORD POUCH

Repair Request Form

Please complete the information below to ensure prompt and accurate service. Include this form with the unit you are returning. Thank you.

Date of return: _____

Company name & _____

Billing address: _____

Contact person: _____

Phone #: _____ Fax #: _____

Email: _____

Purchase Order #: _____

Model #: _____ Serial #: _____

Model #: _____ Serial #: _____

Shipping method to Tesla™: _____

Description of shipping package: _____

Description of problem: _____

Return to Tesla™ Industries, Inc.

101 Centerpoint Boulevard, New Castle, DE 19720 Attention: Repair Department



WE GET THE MILITARY STARTED!

Tesla™ Industries, Inc.

101 Centerpoint Blvd.
New Castle, DE 19720 USA
Tel: 302-324-8910
Fax: 302-324-8912

9475 Double R Blvd., Suite 2
Reno, NV 89521
Tel: 775-622-8801
Fax: 775-622-8810

www.teslaind.com