

# Radio Controlled Solar Aviation Light

AV-425-RF

## Features

- Over 50hrs of continuous operation at FAA non precision MIRLS per AC/150-5345-46D L861 without solar or auxiliary charge in temporary high mode
- OR
- Over 110hrs of continuous operation at ICAO Annex 14 runway edge, 50cd
- Integrated and replaceable Solar Panels - Enables continuous operation
- Optional NVG Mode - Illumination invisible to naked eye to support covert operations
- Worldwide 2.4GHz Encrypted RF Radio Control - Secure control of all operational modes from anywhere on the airfield. Worldwide ISM use frequency
- AvMesh® integrated Mesh Network - Each light is a receiver/transmitter to expand communication range
- Radio Transceiver - Internal to light head, no external antenna
- Modes of Operation - Programmable lighting groups, dusk-till-dawn operation, adjustable intensity, sequence flashing

## Typical Applications

- Solar Runway Edge Light
- Solar Threshold Light
- Approach (Strobe & Fixed)
- Solar Obstruction Light
- Helipad
- Tactical

## Compliance

- Designed to meet photometrics for ICAO Annex 14 Volume 1, 'Aerodrome Design and Operations'. Runway Edge - paragraph 5.3.9. Appropriate for use as threshold - paragraph 5.3.10, 5.3.11 threshold light or end light Approach - paragraph 5.3.4.1A & B, 5.3.4.8 simple approach lighting system
- Designed to meet photometrics for FAA AC/150-5345-46D L861 (High Intensity Mode)

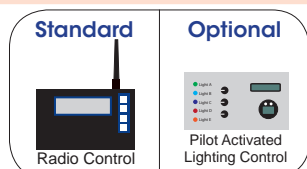

**The AV-425-RF is a robust, completely self-contained LED light designed for a range of emergency aviation applications including runway, threshold, approach, helipad and tactical airfield lighting. Fitted with RF radio control, this fully functioning light can be controlled from the tower with no costly cabling or trenching required.**

The unit is made from cast aluminium, subject to 7-stage powder-coating in aviation yellow. Four premium grade solar modules are integrated into the assembly and mounted to collect sunlight at all angles.

The solar array charges the 24Ah battery during daylight hours, and at dusk the light will automatically begin operation.

16 independently controlled LED drivers within the light optic (patents pending) allow the AV-425-RF fixture to operate as an omnidirectional or bi-directional assembly designed to meet the photometric requirements of FAA L861 runway edge and threshold when set to temporary high mode.

The AV-425-RF has non-precision IFR and VFR capability with both visible and near infrared lighting outputs. The airfield lights can be controlled anywhere in the airfield by handheld radio controller or in the air traffic control tower with virtually unlimited range using an encrypted repeating mesh network.

The AV-425-RF wireless RF light has an extended range through the use of the AvMesh® communication network. The proprietary AvMesh® network enables each light to transmit and receive commands, allowing the airfield to be expanded or altered at any time.

**AvMesh® is self-realizing**, meaning once deployed the airfield lights will undertake a period of network mapping, whereby the system automatically determines an efficient path to relay command messages through the airfield.

**AvMesh® has redundancy.** Once the system has mapped an efficient relay of command messages, a secondary sub-network is mapped for added redundancy.

The AV-425-RF has three selectable modes; always on, dusk-till-dawn and standby. When set to dusk-till-dawn mode, integrated sensors in the light are able to detect when the ambient light threshold drops sufficiently and the light will begin operation automatically.

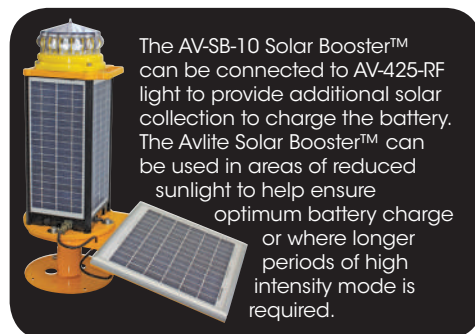

# Radio Controlled Solar Aviation Light

AV-425-RF

Light intensities can be set to Low (10%), Medium (30%), High (100%). Lights are able to be assigned to a 'light group', and groups can be controlled independently using the wireless handheld controller. Sequenced approach can also be easily set up via the serial port and controller.

Tested to MIL-STD's for environmental exposure including shock and vibration, extreme temperature and humidity, the unit is designed to offer years of maintenance-free service and operate in some of the world's harshest environments.

The AV-425 is also available without RF radio control (AV-425).

To suit localised standards, the AV-425-RF can be supplied with optic head designed to comply with either FAA L861 or ICAO Annex 14 photometrics.

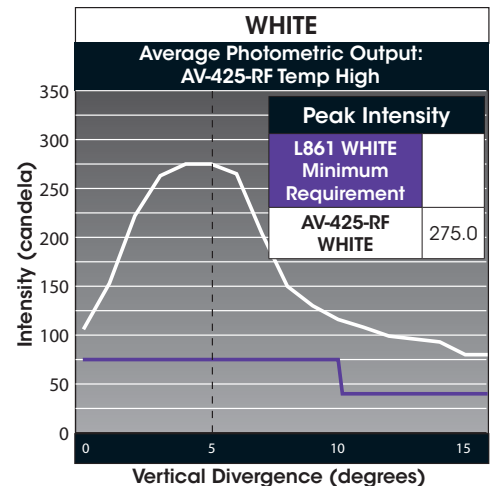

For additional AV-425-RF Photometric Output colors please see the graphical representations on page 3

| SPECIFICATIONS* *                     | AV-425-RF  |
|---------------------------------------|--|
| <b>Light Characteristics</b>          |  |
| Light Source                          | 16 ultra-high intensity LEDs   |
| Available colors                      | Red, Green, White, Yellow, Amber, Blue, Sectored Combinations. IR  |
| Peak Intensity @ temporary high (cd)† | Steady-on: Red - 25.0 Green - 370.0 White - 275.0 Yellow - 92.5  |
| Horizontal Output (degrees)           | As per L861 and L861E  |
| Vertical Divergence (degrees)         | As per L861 and L861E  |
| Available Flash Characteristics       | >250 including steady-on (user-adjustable) including Morse Code and RF sequenced & synchronised flashing   |
| Intensity Adjustments                 | FAA: Low (10%), Medium (30%), High (100%)<br>ICAO: Low (20%), Medium (40%), High (100%)  |
| LED Life Expectancy (hours)           | >100,000   |
| <b>Electrical Characteristics</b>     |  |
| Circuit Protection                    | Integrated   |
| Operating Voltage (V)                 | 12   |
| Temperature Range                     | -40 to 80°C  |
| <b>Solar Characteristics</b>          |  |
| Solar Module Type                     | Multicrystalline   |
| Output (watts)                        | 18   |
| Solar Module Efficiency (%)           | 14   |
| Charging Regulation                   | Microprocessor controlled  |
| <b>Power Supply</b>                   |  |
| Battery Type                          | SLA (Sealed Lead Acid)   |
| Battery Capacity (Ah)                 | 24   |
| Nominal Voltage (V)                   | 12   |
| Autonomy - FAA Optic (hours)          | Steady-on:<br>Low intensity: >320 hours<br>Medium intensity: >130 hours<br>High intensity: >50 hours   |
| Autonomy - ICAO Optic (hours)         | Steady-on:<br>Low intensity: >170 hours<br>Medium intensity: >110 hours<br>High intensity: >60 hours   |
| <b>Radio Controlled</b>               |  |
| Frequency                             | 2.4GHz ISM Band  |
| Range                                 | Up to 1.4km relayed  |
| Expandability                         | AvMesh®  |
| Compliance                            | FCC / CE   |
| <b>Physical Characteristics</b>       |  |
| Body Material                         | 7-stage powder coated aluminium  |
| Lens Material                         | LEXAN® Polycarbonate - UV stabilized   |
| Lens Diameter (mm/inches)             | 155 / 6 1/8  |
| Lens Design                           | 16 segment, multi-focus lens (Patent pending)  |
| Mounting                              | 4 hole 200mm bolt pattern  |
| Height (mm/inches)                    | 507 / 20   |
| Width (mm/inches)                     | 233 / 9 1/8  |
| Mass (kg/lbs)                         | 14 / 30 7/8  |
| Product Life Expectancy               | Up to 12 years   |
| <b>Environmental Factors</b>          |  |
| Humidity                              | 0 to 100%, MIL-STD-810F  |
| Icing                                 | 22kg per square inch   |
| Wind Speed                            | Up to 160kph   |
| Shock                                 | MIL-STD-202G, Test Condition G, Method 213B  |
| Vibration                             | MIL-STD-202G, Test Condition B, Method 204   |
| <b>Certifications</b>                 |  |
| CE                                    | EN61000-6-3:1997. EN61000-6-1:1997   |
| Quality Assurance                     | ISO9001:2008   |
| Waterproof                            | IP68   |
| <b>Intellectual Property</b>          |  |
| Patents                               | Patents pending  |
| Trademarks                            | AVLITE® is a registered trademark of Avlite Systems  |
| <b>Warranty* *</b>                    | 3 year warranty  |
| <b>Options Available</b>              | <ul style="list-style-type: none"> <li>• Avlite Pilot Activated Lighting Control</li> <li>• IR LEDs</li> <li>• Without RF Radio Control</li> </ul> |

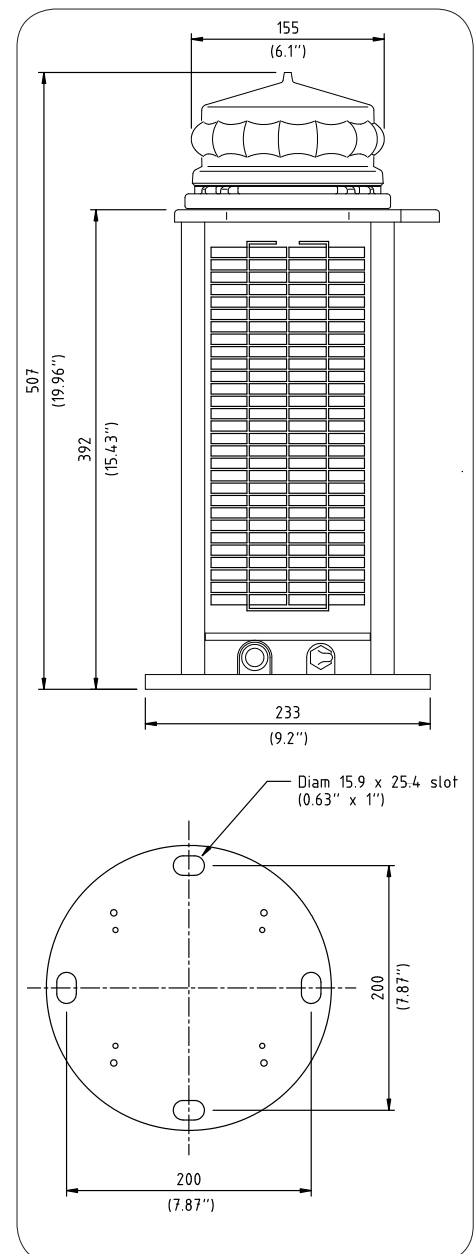

† Intensity setting subject to solar availability  
\* Specifications subject to change or variation without notice  
\* Subject to standard terms and conditions



**Avlite Systems**  
 AUSTRALIA t: +61 (0)3 5977 6128  
 USA t: +1 (603) 737 1310

w: [www.avlite.com](http://www.avlite.com)  
 e: [info@avlite.com](mailto:info@avlite.com)



# Radio Controlled Solar Aviation Light

AV-425-RF

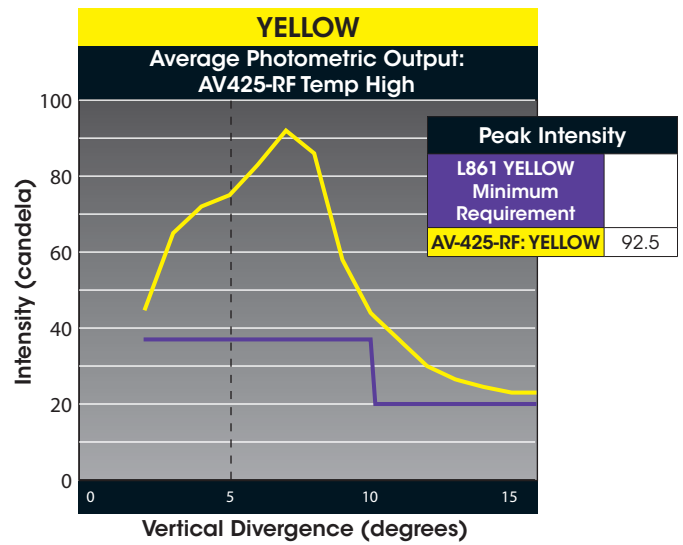
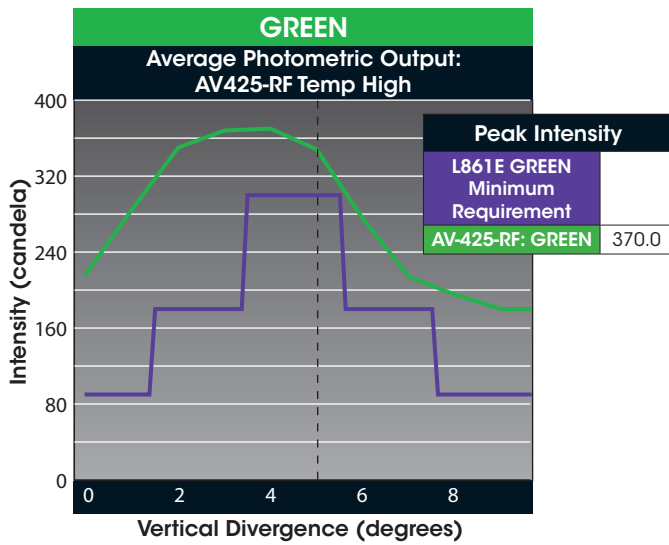
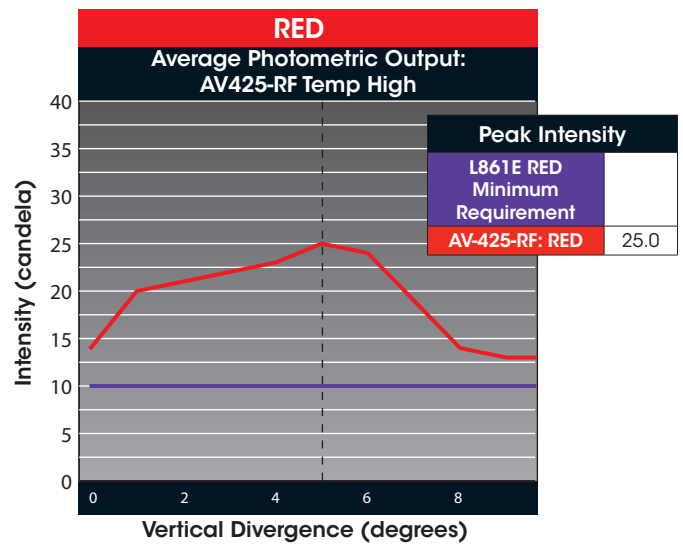
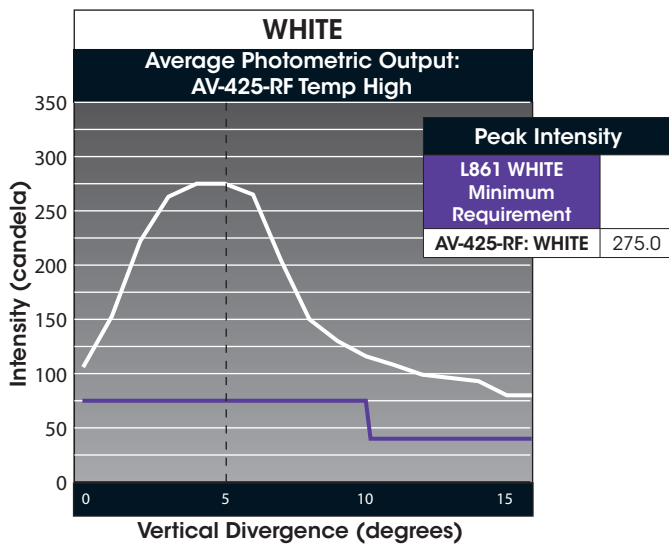

**Note:** The figures shown in the above graphs are for 100% (Temp High) Mode



## AV-425-RF

### Radio Controlled Solar Aviation Light Installation & Service Manual

# AV-425-RF

## Solar Aviation Light

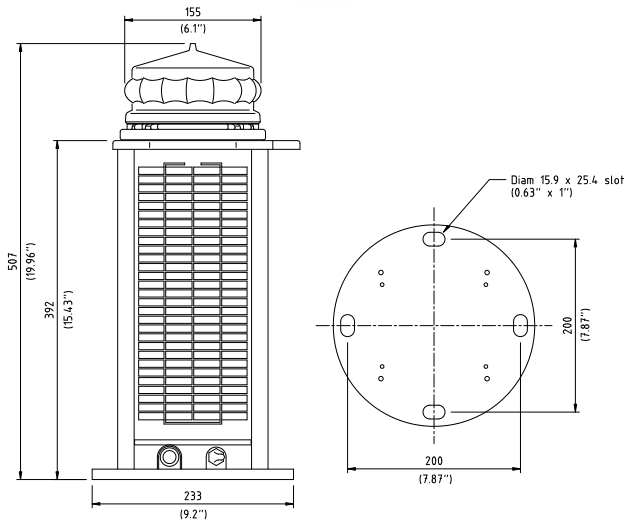

## Table of Contents

|   |         |
|---|---------|
| <b>Introduction</b> .....   | Page 4  |
| <b>Technology</b> .....   | Page 4  |
| <b>AV-425-RF Model</b> .....  | Page 5  |
| <b>Activation</b> .....   | Page 7  |
| <b>Avlite Radio Controller</b> .....  | Page 8  |
| <b>Assembly &amp; Installation of Radio Controller</b> .....                        | Page 9  |
| <b>Radio Controller Menu</b> .....  | Page 10 |
| <b>Radio Controller System Setup</b> .....  | Page 12 |
| <b>Using the Radio Control to Activate the Airfield Lighting System (ALS)</b> ..... | Page 20 |
| <b>Installation</b> .....   | Page 22 |
| <b>Solar Calculation &amp; Operating Capabilities</b> .....                         | Page 25 |
| <b>Simple Approach Lighting</b> .....   | Page 26 |
| <b>Runway End Identifier Light (REIL)</b> .....                                     | Page 28 |
| <b>Maintenance and Servicing</b> .....  | Page 30 |
| <b>Trouble Shooting</b> .....   | Page 35 |
| <b>Documentation</b> .....  | Page 37 |
| <b>AV-SB-10 Solar Booster™</b> .....  | Page 38 |
| <b>Solar Booster™ Installation Procedure</b> .....                                  | Page 40 |
| <b>Avlite Light Warranty</b> .....  | Page 42 |

| Version No. | Description                        | Date          | Approved   |
|-------------|------------------------------------|---------------|------------|
| 1.0         | Manual Launch                      | October 2010  | M. Henry   |
| 1.1         | Spec Update & Solar Booster        | November 2010 | M. Henry   |
| 1.2         | Addition: Reil & Approach lighting | November 2011 | M. Henry   |
| 1.3         | Alteration to Installation section | May 2012      | C. Procter |
| 2.0         | New Product Code                   | January 2013  | J. Dore    |
| 2.1         | Torque setting                     | February 2014 | P. Rainey  |
| 2.2         | REIL flash character added         | March 2015    | T. Stewart |



## Introduction

**Congratulations! By choosing to purchase an Avlite light, you have become the owner of one of the most advanced solar LED airfield lights in the world.**

Avlite Systems draws on more than 25 years experience in the design and manufacture of navigation aids, and particular care has been taken to ensure your light gives years of trouble free service.

As a commitment to producing the highest quality products for our customers, Avlite has been independently certified as complying with the requirements of ISO 9001:2008 quality management system.

By taking a few moments to browse through this booklet, you will become familiar with the versatility of your light, and be able to maximise its operating function.

Please remember to complete the Avlite warranty registration card accompanying your light.

## Technology

***Avlite Systems is a world-class solar lighting systems manufacturer with a proven reputation for rapid, innovative, and agile technology solutions designed specifically for defense, government, civil and humanitarian aid operations in the most remote, toughest environments.***

### **Electronics**

Avlite employs leading in-house electronic engineers in the design and development of software and related circuitry. All individual electronic components are sourced directly by Avlite procurement staff ensuring that only the highest quality components are used in our products.

### **LED Technology**

All aviation lights use the latest advancements in LED (Light Emitting Diode) technology as a light source. The major advantage of LED's over traditional light sources is well established in that they typically have an operational life in excess of 100,000 hours, resulting in substantial savings to maintenance and servicing costs.

### **Precision Construction**

Commitment to investing in the design and construction of injection-moulded parts including optic lenses, light bases and a range of other components ensures that all Avlite products are of a consistent and superior quality.

### **Optical Performance**

Avlite manufactures a range of aviation LED lenses moulded from multi-cavity dies. The company has superior in-house lens manufacturing capabilities to support outstanding optical performance.

### **Award-winning, Patented Technology**

Several United States and Australian patent registrations are held on Avlite's range of innovative designs, with other regional patents pending in Canada, United Kingdom and Europe.



## **AV-425-RF Model**

*The robust design of the AV-425-RF self-contained light ensures up to 12 years of reliable service with minimal ongoing maintenance.*

*Specifically designed to survive the harshest environments the AV-425-RF features seven stage powder coated aluminium top, base and internal chassis. The corners are made from UV stabilised rubber. This method allows the customer to change a solar panel in the unlikely event of damage.*

*The top casting is constructed with an integrated handle that helps with any manual handling of the unit.*

*The high impact resistant polycarbonate lens ensures even light visibility.*

*The solar panels provide efficient and year round charging of the large 12V 20Ah SLA battery.*

*The four hole bolt pattern will fit directly onto any 200mm OD mount.*

*The AV-425-RF is fitted with an external ON/OFF switch; this means the light can be turned on once in position, with the flick of a switch. It is also fitted with an external charging port for charging the battery while it is stored for extended periods.*

*When the AV-425-RF is used in conjunction with an RF Network (FCC compliant), a number of options are available such as the ability to use visible and IR LEDs fitted to the same light head.*

*All this is backed by Avlite's industry leading, 3-year warranty.*

*To suit localised standards, the AV-425-RF can be supplied with optic head to comply with either FAA L861 or ICAO Annex 14 photometrics.*



**SPECIFICATIONS\* \*****AV-425-RF****Light Characteristics**

Light Source  
 Available colors  
 Peak Intensity @ temporary high (cd)†  
 Horizontal Output (degrees)  
 Vertical Divergence (degrees)  
 Available Flash Characteristics

Intensity Adjustments

LED Life Expectancy (hours)

**Electrical Characteristics**

Circuit Protection  
 Operating Voltage (V)  
 Temperature Range

**Solar Characteristics**

Solar Module Type  
 Output (watts)  
 Solar Module Efficiency (%)  
 Charging Regulation

**Power Supply**

Battery Type  
 Battery Capacity (Ah)  
 Nominal Voltage (V)  
 Autonomy - FAA Optic (hours)

Autonomy - ICAO Optic (hours)

**Radio Controlled**

Frequency  
 Range  
 Expandability  
 Compliance

**Physical Characteristics**

Body Material  
 Lens Material  
 Lens Diameter (mm/inches)  
 Lens Design  
 Mounting  
 Height (mm/inches)  
 Width (mm/inches)  
 Mass (kg/lbs)  
 Product Life Expectancy

**Environmental Factors**

Humidity  
 Icing  
 Wind Speed  
 Shock  
 Vibration

**Certifications**

CE  
 Quality Assurance  
 Waterproof

**Intellectual Property**

Patents  
 Trademarks

**Warranty\*****Options Available**

16 ultra-high intensity LEDs  
 Red, Green, White, Yellow, Amber, Blue, Sectored Combinations. IR  
 Steady-on: Red - 25.0 Green - 370.0 White - 275.0 Yellow - 92.5

As per L861 and L861E

As per L861 and L861E

>250 including steady-on (user-adjustable) including Morse Code and RF sequenced & synchronised flashing

FAA: Low (10%), Medium (30%), High (100%)

ICAO: Low (20%), Medium (40%), High (100%)

>100,000

Integrated

12

-40 to 80°C

Multicrystalline

18

14

Microprocessor controlled

SLA (Sealed Lead Acid)

24

12

Steady-on:

Low intensity: >320 hours

Medium intensity: >130 hours

High intensity: >50 hours

Steady-on:

Low intensity: >170 hours

Medium intensity: >110 hours

High intensity: >60 hours

2.4GHz ISM Band

Up to 1.4km relayed

AvMesh®

FCC / CE

7-stage powder coated aluminium

LEXAN® Polycarbonate – UV stabilised

155 / 6<sup>1</sup>/<sub>8</sub>

16 segment, multi-focus lens (Patent pending)

4 hole 200mm bolt pattern

507 / 20

233 / 9<sup>1</sup>/<sub>8</sub>

14 / 30<sup>7</sup>/<sub>8</sub>

Up to 12 years

0 to 100%, MIL-STD-810F

22kg per square inch

Up to 160kph

MIL-STD-202G, Test Condition G, Method 213B

MIL-STD-202G, Test Condition B, Method 204

EN61000-6-3:1997. EN61000-6-1:1997

ISO9001:2008

IP68

Patents pending

AVLITE® is a registered trademark of Avlite Systems

3 year warranty

- Avlite Pilot Activated Lighting Control
- IR LEDs
- Without RF Radio Control

\* Specifications subject to change or variation without notice  
 \* Subject to standard terms and conditions  
 † Intensity setting subject to solar availability



## Activation

### Charging the Battery

*New lights should be left in the sun for several days to ensure battery is charged before placing in service.*

### Preferred Installation Location

*For best light performance, ensure solar modules are not covered and are in clear view of the sky with no shadows.*

### Lantern Operation

The AV-425-RF is activated via the ON/OFF switch, at the base of the unit.

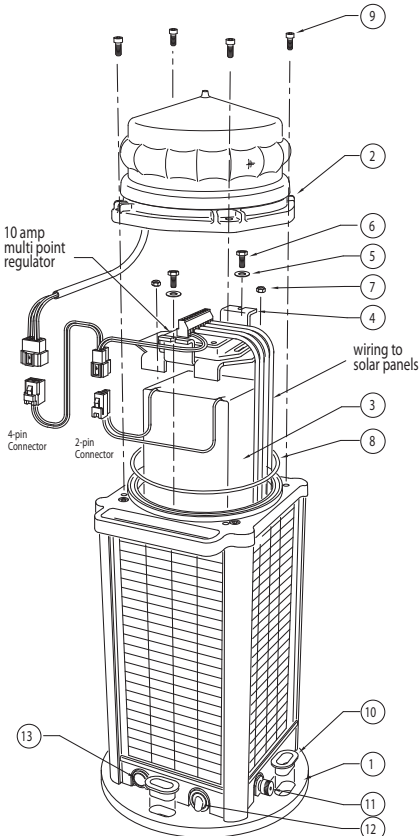

| Item | Description               | Quantity |
|------|---------------------------|----------|
| 1    | AV425 Base                | 1        |
| 2    | AV425 Lens Assembly       | 1        |
| 3    | Battery 12v 24Ah          | 1        |
| 4    | Battery Clamp             | 1        |
| 5    | Washer M4                 | 2        |
| 6    | M4 Cap Screw              | 2        |
| 7    | M5 Nylock Nut             | 2        |
| 8    | O-Ring, ID 145 x 4.0      | 1        |
| 9    | Socket Head Screw M6 x 16 | 4        |
| 10   | Mounting Insert           | 4        |
| 11   | External Charging Port    | 1        |
| 12   | ON/OFF Switch             | 1        |
| 13   | Momentary Button          | 1        |

Fig 2. AV-425-RF Solar Light components

## Avlite Radio Controller

The Avlite Radio Controller is a compact handheld unit that allows complete control of the airfield lighting system. The unit allows for easy activation, inspection and testing of the airfield lights. The Avlite Radio Controller works on the 2.4GHz ISM Band using a low power RF module. The backlit, LCD can be seen during day or night. The straightforward menu makes the ALS easy to operate.

The Avlite Radio Controller comes standard with an IP68 rated charging plug, omni-directional antenna and ON/OFF switch and cover.

The Radio Controller and charger come in an IP68 'Pelican' Case to protect it from the harsh environment to which it may be subjected.

The Avlite Radio Controller can be rack mounted in a standard 19" rack for use with other airfield electronic equipment such as Pilot Activated Lighting Control (PALC).

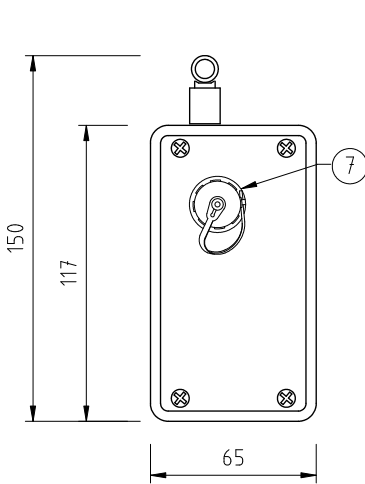

**Fig 4 Radio Controller Side View**

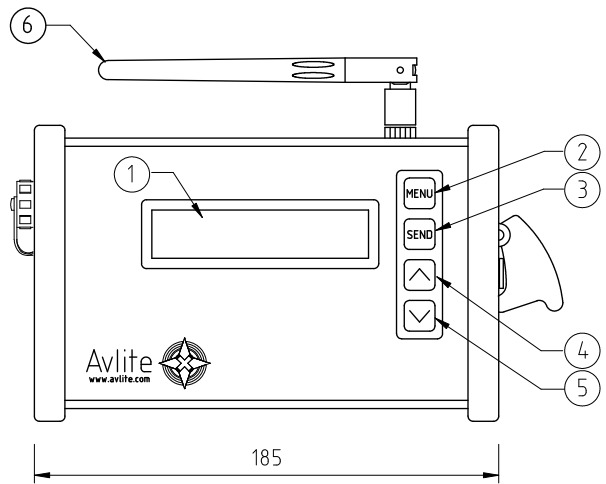

**Fig 5 Radio Controller Front View**

- 1 LCD Screen
- 2 MENU Button
- 3 SEND Button
- 4 UP Button
- 5 DOWN Button
- 6 6" Di pole Omni Directional, Right Angle Whip Antenna
- 7 Charging Port – IP68 sealed plug. (Charger not shown)



## Assembly & Installation of Radio Controller

The installation of the Radio Controller includes the following steps:-

- Unpacking
- Initial Inspection
- Assembling & Charging the Radio Controller
- Using the Radio Controller

### Components

Your pelican case contains the following:

- 2.4GHz Radio Controller
- Charger
- Power Supply for charger
- Programming Cable

Please contact your Avlite office if there is any hardware missing.

### Initial inspection

Inspect the Radio Controller for damage. If there is any damage, please contact your Avlite office. Retain original packing material for possible future use.

### Assembly & Charging

The Radio Controller can be activated after raising the aerial into the upright position, see Fig 5.

It is advisable to charge the Radio Controller before use.

### Turning the Unit On

To turn the unit on, lift the red missile cover and turn the switch to the ON position.

The radio controller will take 5 seconds to start up and it may take up to 30 seconds for the embedded RF Module to be configured, before a command can be sent.

### Charging the Radio Controller

- a. Unscrew the protective cap from the charging port, on the left side of the Radio Controller.
- b. Insert the charging terminal into the Radio Controller.
- c. Plug the charger into a wall socket and turn the charger on.
- d. The light on the charger will flash Green, Orange, Red then back to Orange.
- e. The charger has a LED to indicate the charge sequence.
  - i. Green – Unit is fully charged. The Radio Controller can be left connected in state.
  - ii. Orange – Unit is charging. The unit will charge for a maximum of 8 hours before automatically shutting down.
  - iii. Red – A fault is occurring, please contact Avlite Office.



## Radio Controller Menu

This section of the document will provide a short explanation of all the menu screens on the control unit.

### Operation Mode

The Operation Mode defines how the light will respond to different environmental conditions & user inputs. There are three operational modes that can be selected via the controller. *ON*, *STANDBY* & *DUSK to DAWN*.

#### ALWAYS ON Operation Mode

The light is *Always On*. The light will be on both night & day until it is commanded to OFF. While the light is in this mode it will only turn off when the battery drops below the Flat Battery Voltage level. (AV-425-RF = 10.5V)

#### STANDBY Operation Mode

LEDs are OFF but light will respond to and pass commands sent by the radio controller. This mode should be used if the lights have been installed outside but are not currently required.

**Note:** The light is not completely powered down in a manner suitable for storage. If the light is to be stored in a warehouse or other dark environment the ON/OFF switch should be turned off.

#### DUSK to DAWN Operation Mode

The light is turned on and off based on the light sensor input. Sensors include a light sensor internal to each light and the light will turn on when the ambient light threshold falls below 100 lux and will turn off once the ambient light threshold reaches 150 lux.

### Advanced Op Mode

This enables you to select visible or near IR LEDs. The options include *VISIBLE LEDs* & *IR/NGV LEDs*.

**Note:** this menu will not be enabled if the selected Operation Mode is *STANDBY*

### Light Group

This menu is used to select the current light group. The controller can select any one of the 15 individual light groups. Taxiway lights, sign lights and runway lights are able to be controlled separately using programmable groups.

( 0 -> 15) or select all radio lights at once.

**Note:** *The units are set with a light group of 0 in the factory.*

### LED Intensity

Default = LOW

This menu is used to select the intensity of the LEDs on the light. The options include *Low*, *Medium* & *High*.

- a. Low – LED intensity is set to low setting
- b. Medium - LED intensity is set to medium intensity
- c. High - LED intensity is set to high intensity

**Note:** this menu will not be enabled if the selected operational mode is *STANDBY*

### Timeout Mode

This menu is used to setup the LED high intensity timeout feature found in each light. Light will revert from high intensity to low intensity after a programmable duration. The options include *Enabled LOW*, *Disable*.

- a. Enabled LOW – The immediate LED intensity is selected via the LED Intensity menu, after Timer Duration the LED Intensity will revert back to the LOW setting
- b. Disable – The high intensity LED timeout is disabled. The LED intensity will be selected via the LED intensity menu.

**Note:** this menu will not be enabled if the selected operational mode is *STANDBY*

### Timeout Duration

This menu is only visible when the timeout Mode is enabled. This menu is used to select the timeout duration, the time before the LED intensity reverts back to its LOW intensity state. The timeout duration can be set from 1 minute to 60 minutes.

### Diagnostic

This feature can be used to check the battery voltage in every light in the airfield. The command can be sent any time and it will not affect the current state of the light. If the light is in STANDBY mode the light will flash as shown below and revert to STANDBY mode after the diagnostic has been completed. For additional diagnostic information please see Section 3 of the 'Radio Control System Setup' section of this manual.

#### EXTERNAL POWER Diagnostic

Checks for external power connection

#### NODE (MAIN NET) Diagnostic

Checks which lights are nodes in the main network

#### NODE (SUB NET) Diagnostic

Checks which lights are nodes in the sub network

#### BATTERY (HEALTHY) Diagnostic

Battery above 12.5V

#### BATTERY (LOW) Diagnostic

Battery above 10.5V, but below 12.5V

#### BATTERY (FLAT) Diagnostic

Battery below 10.5V

#### Diagnostic Pass (1 x 1 second flash)

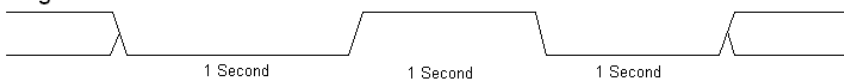

#### Diagnostic Fail (2 x 300 milli second flashes)

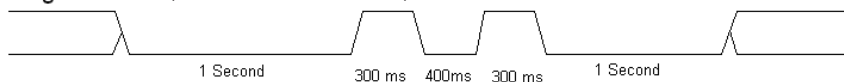

### Radio Encryption

The AV-425-RF is fitted with 128bit Radio Encryption. This includes user-adjustable encryption keys and 12 user-adjustable channel settings.

### Synchronization

The integrated mesh network radio system can provide true synchronization flash patterns including flare paths and approach sequences.

### Sending Commands

Every time the SEND button is pressed a command is sent containing all the current settings in the Radio Controller.

The SEND button can be used after changing one setting or after changing multiple settings.

## Radio Control System Setup

Your radio control system has been shipped preprogrammed with a default 128 bit encryption key. It is not necessary to alter the default encryption key, however, if required the encryption key can be changed (see Section 1, i.).

**Note: If you change the radio control encryption key in Section 1, it will be necessary to change the encryption key in ALL the lights in the system**

To ensure trouble free set up of the Radio control System it is necessary to step through the following set up procedures. The setting up of the Radio control system is divided into 3 sections

**Section 1** - Programming the Radio Control System (must be done before Section 2 and 3)

**Section 2** - Programming the light, using a direct cable connection

**Section 3** - Operating the lights using the controller

### Section 1

#### Programming the Radio Control System

1. Fold out the aerial on the top of the ALS 2.4 GHz Handheld Radio Controller.
2. Turn on the ALS 2.4GHz Handheld Radio Controller by actuating the red rocket switch on the side of the controller



3. Press and hold the menu button for 3 seconds
4. The screen will display the following message:
5. The Menu contains the following Sub menu  
(Press the Menu button to step between the menu items)
  - a. **[Screen back light]**  
Using the [UP] or [DOWN] keys select from:  
[0-100%]
  - b. **[Connection Method]**  
Using the [UP] or [DOWN] keys select from:  
[Radio Control] - *standard wireless connection*  
[Direct Connection] - *use for programming light*



**c. [Flash Code Selection]**

Using the [UP] or [DOWN] keys select from:  
[Disable]  
[Enable]

**d. [Sync Menu Selection]**

Using the [UP] or [DOWN] keys select from:  
[Disabled]  
[Enabled]

**e. [Advanced Operation]**

Using the [UP] or [DOWN] keys select from:  
[Disabled]  
[Enabled]

**f. [Diagnostic]**

Using the [UP] or [DOWN] keys select from:  
[Disabled]  
[Enabled]

**g. [Radio Information]**

Displays the address of the radio in the ALS2.4GHz Hand Held Controller  
Note: There are no user-adjustable settings in this menu item

**h. [Radio Channel]**

**Note:** There are two sub menus in this menu. To toggle between the two Sub menus, press both the [UP] and [DOWN] keys together at the same time.

Using the [UP] or [DOWN] keys select from:  
[Encrypted]  
[Unencrypted]

Using the [UP] or [DOWN] keys select from:  
[0C-17]

**i. [Radio Encryption Key]**

**Note: If you change the radio control encryption key in Section 1, it will be necessary to change the encryption key in ALL the lights in the system**

Using the [UP] and [DOWN] keys set the encryption key. Hold down the key to scroll quickly to the required number.

Pressing both the [UP] and [DOWN] keys together will toggle across the encryption key in banks of 2 digits.

Set the encryption key in banks of 2 digits.

For Example:

To set an encryption Key of 12345678910111213141

The digits would be set in pairs of 12 34 56 78 91 01 11 21 31 41

Using the [UP] or [DOWN] keys select any combination from

[00000000000000000000 to FFFFFFFFFFFFFFFFFFFFFF]

**Record and keep this Encryption key secure in case the controller becomes lost or broken.**





*The encryption key can be re-entered into the new controller without the need to reprogram all the lights in the Radio Control System.*

*Encryption key cannot be 00000000000000000000*

Press [SEND] to save the Radio Control System settings

**Note:** Failure to select appropriate settings and save the settings will result in the Radio Control System not being appropriately optioned.

**Congratulations you have now set up your Radio Control System please continue to the next section to setup each light in the system.**

## **Section 2**

### **Programming the light using the cable interface and hand held controller**

**NOTE:** In this programming mode it is necessary to press send to save each option as each option is selected in the sub menu, before moving to the next sub menu item. Failure to press send before moving to the next menu item will result in selections not being saved.

1. The programming port is located under the light head. It is necessary to remove the light head to access this programming port.
2. Ensure that the light is turned off at the red master switch on the control panel at the base of the solar unit
3. Remove the 4 socket head cap screws and remove the light head from the solar unit enough to access the programming port. The light needs to remain connected the solar unit. Remove the blue waterproof cap from the programming port.



4. Connect the programming cable to the light head.
5. Connect the programming cable to the programming/charging port located on the left hand side of the ALS2.4GHz handheld radio controller.
6. Turn on the controller at the Red Master switch located on the right hand side of the ALS 2.4 GHz handheld radio controller.

7. Turn on the light at the red master switch on the solar chassis.
8. Unit is ready to receive programming signals.  
**Note:** Light head needs to be connected to the solar chassis during programming to be able to receive power enabling it to be programmed.
9. Press and hold the [MENU] button for 3 Seconds. The screen will display the following message.



10. Using the menu key scroll down the submenu to [CONNECTION METHOD]
11. Using the [UP] and [Down] keys select [DIRECT CONNECTION]



12. Press [SEND]
13. This Menu contains the following Sub Menu  
Press [MENU] to scroll through the menu

**Note:** In this menu the programmed option will be indicated by a ✓, if the option is indicated by an X then this option has not been selected and saved. Press [SEND] to save options at each change.

**a. Lantern Info**

This displays the current Light information only, there are no adjustable options.

- Type
- Version
- Radio



**b. Operation Mode**

Using the [UP and [DOWN] keys select from the following:

- [Always On]
- [Dusk till Dawn]
- [Standby]

Press [SEND] after selection

**c. Advanced Operation Mode** (if Advanced Operation Mode is enabled during Radio Control System Programming - Section 1)

Using the [UP and [DOWN] keys select from the following:

- [Visible LEDES]
- [IR/NVG LEDES]

Press [SEND] after selection

**d. Light Group**

Using the [UP and [DOWN] keys select from the following:

- [0-15] (Select any one of the 0-15 light groups)

Press [SEND] after selection

**e. Intensity**

Using the [UP and [DOWN] keys select from the following

- [Low]
- [Medium]
- [High]

Press [SEND] after selection

**f. Flash Code** (if Flash Code is enabled during Radio Control System Programming - Section 1)

Using the [UP and [DOWN] keys select from the following

- [000 to 1FF]

A full list of available flash codes is available from Avlite

Press [SEND] after selection

**g. Sync Offset** (if Synchronisation is enabled during Radio Control System Programming - Section 1)

**Note:** Sync offsets can be set using an absolute value or a percentage (Flash Delay) of the flash sequence or a combination of both. If you select Sync Offset value and also Sync delay value, the combination offset/delay value will be the combined total of both values.

Using the [UP and [DOWN] keys select from the following:

- [-10.23 to +10.23] seconds

Press [SEND] after selection

**h. Sync Delay** (if Synchronisation is enabled during Radio Control System Programming - Section 1)

Using the [UP and [DOWN] keys select from the following

- [0 to 99.6%]

Press [SEND] after selection



**i. Radio Channel**

**Note:** There are two sub menus in this menu. To toggle between the two Sub menus, press both the [UP] and [DOWN] keys together at the same time.

Using the [UP] or [DOWN] keys select from:

- [Encrypted]
- [Unencrypted]

Using the [UP] or [DOWN] keys select from:

- [0C-17]

Press [SEND] after selection

**j. Radio Encryption Key (If Encryption is Enabled during Radio Control System Programming- Section 1)**

Set the encryption key in banks of 2 digits.

For Example

To set an encryption Key of 12345678910111213141

The digits would be set in pairs of 12 34 56 78 91 01 11 21 31 41

Using the [UP] and [DOWN] keys set the encryption key. Hold down the key to scroll quickly to the required number.

Pressing both the [UP] and [DOWN] keys together will toggle across the encryption key in banks of 2 digits.

[Insert Radio Encryption Key]

**Note:** Radio Encryption Key must be the same key as set in the Radio Control system (section 1) or the light will not respond to the controller.

Press [SEND] after selection

**Note:** Turn the light off at the red master switch, before disconnecting the Hand Held Radio interface cable. The light must be depowered before the settings will take effect.

**Repeat this process for every light in the system**

**Important:** When you have finished programming all of the lights the Radio Controller must be put back into Radio Connection Mode

1. Using the menu key scroll down the submenu to [CONNECTION METHOD]
2. Using the [UP] and [Down] keys select [RADIO CONNECTION]
3. Press [SEND] to save settings.

Failure to place the Radio Controller back into RADIO CONNECTION mode will cause the Radio Controller to be unable to communicate with the lights

***Congratulations you have now programmed your lights to your Radio Control System please continue to the next section.***



### Section 3

#### Operating the lights using the ALS 2.4GHz Handheld Controller

**Note:** Some menu options may not appear if they were not enabled in the Radio Control System set up menu, and programmed in to the light.

1. Fold out the aerial on the top of the ALS 2.4 GHz handheld Controller.
2. Turn on the ALS 2.4GHz Handheld radio Controller by actuating the red rocket switch on the side of the controller
3. The Menu contains the following Sub menu

Press the [MENU] button to scroll through the Sub Menu

##### a. Operation Mode

Using the [UP and [DOWN] keys select from the following:

- [Always On]
- [Dusk till Dawn]
- [Standby]

##### b. Advanced Operation Mode (If Enabled during Radio Control System Programming- Section 1)

Using the [UP and [DOWN] keys select from the following:

- [Visible LEDES]
- [IR/NVG LEDES]

##### c. Light group

Using the [UP and [DOWN] keys select from the following:

- [0-15] (Select any one of the 0-15 light groups)
- [All] (Selects all of the light groups)

##### d. Intensity

Using the [UP and [DOWN] keys select from the following:

- [Low]
- [Medium]
- [High]

##### e. Timeout Mode

Using the [UP and [DOWN] keys select from the following:

- [Enabled, Low] (Recommended)
- [Disabled]

##### f. Timeout Duration

Using the [UP and [DOWN] keys select from the following:

- [1-60 Minutes]

##### g. Flash Code (If Enabled during Radio Control System Programming- Section 1)

Using the [UP and [DOWN] keys select from the following

- [000 to 1FF]

**h. Sync Mode (If Enabled during Radio Control System Programming- Section 1)**

Using the [UP and [DOWN] keys select from the following:

[Full] (Use for Flare Path or Approach sequence)

[Basic] (Use for synchronised Flashing)

[Disabled]

**i. Diagnostic**

For the following diagnostic tests to following diagnostic flash results can be displayed for the light.

**Diagnostic Pass** (1 x 1 second flash)

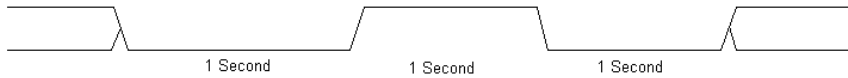

**Diagnostic Fail** (2 x 300 milli second flashes)



Using the [UP and [DOWN] keys select from the following

[Node Sub Net]

Pass= Confirms light is a node on the Sub Network

[Node Main Net]

Pass= Confirms light is a node on the Main Network

[External Power]

Pass= Confirms external power is connected via HVPS

[Battery Flat]

Pass= Confirms battery voltage is under 10.5 Volts

[Battery Low]

Pass= Confirms battery voltage is between 10.5 and 12.5 Volts

[Battery Healthy]

Pass= Confirms battery voltage is over 12.5 Volts

Press [Send] to receive a diagnostic flash sequence

When the controller is in operation mode, multiple changes can be set and sent at the same time. It is not necessary to press send after each change.



## Using the Radio Control to Activate the Airfield Lighting System (ALS)

The Radio Controller is very easy to use and by reading through the How To section below, all of the advanced features will be well within your grasp.

Make sure that all the lights in the same Light Group.

### Turn All the Lights ON

- Turn the Radio Controller On
- Use the arrow keys to adjust the operational Mode to *ON*
- Press *MENU* button once to reach *Light Group*
- Set the Light Group to ALL
- Press *SEND* button
- Every radio light within range of the control unit will now turn on.

### Setup the Lights to Operate in DUSK till DAWN mode

- Turn the Control unit On
- Use the arrow keys to adjust the operational Mode to *DUSK till DAWN*
- Press *MENU* button once to reach *Light Group*
- Set the Light Group to ALL
- Press *SEND* button
- Every radio light within range of the control unit will now turn on at night, during the day the lights will turn off automatically.

### Runway B Only is to be HIGH Intensity, but Runway A will Remain in Current Configuration

- On Runway A, set the light group to 0 (follow the instruction in Section 2 in the 'Radio Control System Setup' section of this manual.
- On Runway B, set the light group to 1 or any group different to Runway A..
- Turn the Control unit On
- Use the arrow keys to adjust the operational Mode to *Always On*
- Press *MENU* button to reach *Light Group*
- Set the Light Group to 1
- Press *MENU* button to reach *LED Intensity*
- Use the arrow keys to adjust the LED Intensity to *HIGH*
- Press *MENU* button to reach *Advanced Operation Mode*
- Use the arrow keys to select *Visible LEDs*
- Press *SEND* button
  - *Runway A will not change state.*
  - *Runway B will now be High Intensity.*

**Runway B Only is to be HIGH Intensity, with a Timeout of 8 Minutes and Runway A will be I/R Low Intensity**

- On Runway A, set the light group to 0.
- On Runway B, set the light group to 1.
- Turn the Control unit On
- Use the arrow keys to adjust the operational Mode to *Always On*
- Press *MENU* button to reach *Light Group*
- Set the Light Group to 1
- Press *MENU* button to reach *LED Intensity*
- Use the arrow keys to adjust the LED Intensity to *HIGH*
- Press *MENU* button to reach *Timeout Mode*
- Use the arrow keys to adjust the Timeout Mode to Enabled *LOW*
- Press *MENU* button to reach *Timeout Duration*
- Use the arrow keys to adjust the Timeout Duration to *8 Minutes*
- Press *SEND* button
  - *Runway A will not change state.*
  - *Runway B will now be High Intensity. After 8 minute Runway will revert back to LOW intensity.*
- Press *MENU* button until you reach *Light Group*
- Set the Light Group to 0
- Press *MENU* button once to reach *LED Intensity*
- Use the arrow keys to adjust the LED Intensity to *LOW*
- Press *MENU* button to reach *Advanced Operation Mode*
- Use the arrow keys to select *IR/NGV LEDs*
- Press *SEND* button
  - *Runway A will be in LOW Intensity IR mode*
  - *Runway B will not change state. Lights on Runway B will still receive and pass on the message intended for Runway A.*



## Installation

### Runway Edge / Light Height Diagram

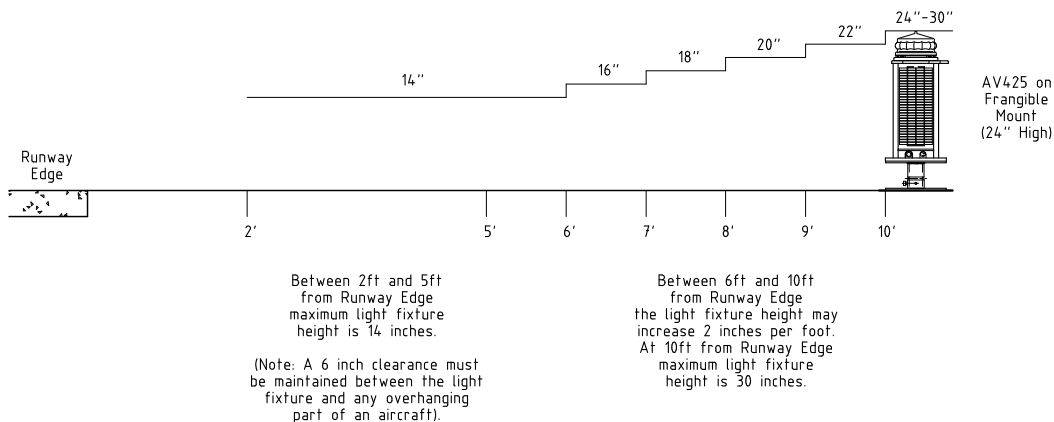

### Installing the Light Assembly to the Frangible Stake Mount

The completed AV-425-RF - mount plate assembly is to be mounted on the stake in firm soil (not loose sand, screenings or other unbound material).

- Fit the AV-425-RF on the top of the mounting plate. Insert bolts through the four holes in the mount, entering from the bottom. Install a penny washer and a Nylock nut on each bolt. Tighten Nylock nuts.
- Use a sledge hammer to drive the stake into the soil at the chosen location. Drive the stake down until the bottom of the stake sleeve is at ground level.
- Fit the AV-425-RF and mounting plate assembly on top of the stake. The point of frangibility should be completely clear of the stake sleeve or ground support hardware. Use the socket head cap screws supplied to hold the frangibility point above the sleeve. Using a 6mm Allen key, tighten the bottom socket head cap screws against the stake sleeve.

**Note:** After adjustments, ensure all nuts and bolts are tightened securely and all tools, spares and packaging are removed from the runway.

### Installing the Light Assembly to the Frangible Concrete Mount

- Mount the base plate to the concrete using 4 x M8 concrete bolts.
- Fit the frangible mounting plate onto the concrete base plate and secure using the M8 x 16 SHCS
- Level the light mounting plate using a spirit level.
- Fit the AV-425-RF to the light mounting plate using M8 SHCS, large flat washers and Nylock nuts.
- For further adjustments on levelling the light, see next section on leveling the light.

**Note:** After adjustments, ensure all nuts and bolts are tightened securely and all tools, spares and packaging are removed from the runway.

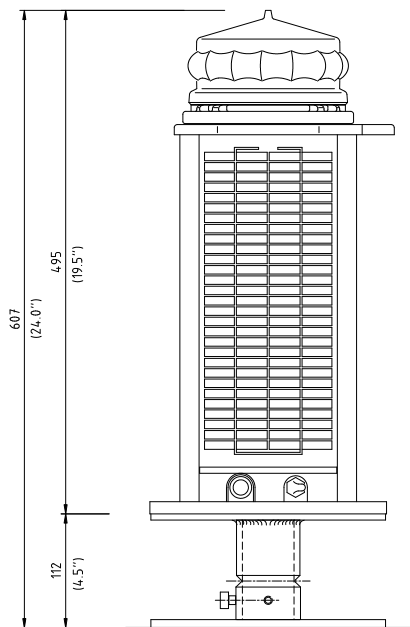

**AV-425-RF on Frangible Mount**

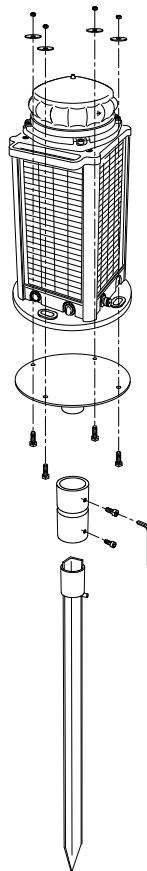

**Levelling the light**

During Installation every effort should be made to ensure that the light is level when installation is complete.

The following guide lines will help to ensure that the lights will be installed correctly.

- When installing a stake mount into the ground ensure that the stake is installed straight into the ground and not on an angle.
- When installing a concrete mount plate ensure that the concrete pad is level using a spirit level.



**Check the mounting plate with a spirit level in all directions**

- Fit the frangible coupling and top mounting plate and using a spirit level check that the light mounting plate is level using a spirit level.
- If the mounting assembly can not be levelled to a satisfactory plane, then spacers can be used under the 4 mounting points to complete levelling.
- Spacers must be secured. Flat penny Washers that can be placed under the 4 mounting points and secured in place by the mounting bolts.



- Washers of different thicknesses can be used, as can multiple washers.



**Incorrect Installation**

One spacer fitted here either side of the two washers

Two spacer fitted here



**Correct Installation**

**Important:** Please ensure that spacers are not just under one mounting point. Please fill in spacers under other mounting points. Failure to space gaps will result in damage to the base or the mounting plate.

## Solar Calculation & Operating Capabilities

For information relating to charging and power please refer to the Avlite Power Calculator.

To obtain a copy of the Avlite Power Calculator please contact your Avlite Distributor or email [info@avlite.com](mailto:info@avlite.com)

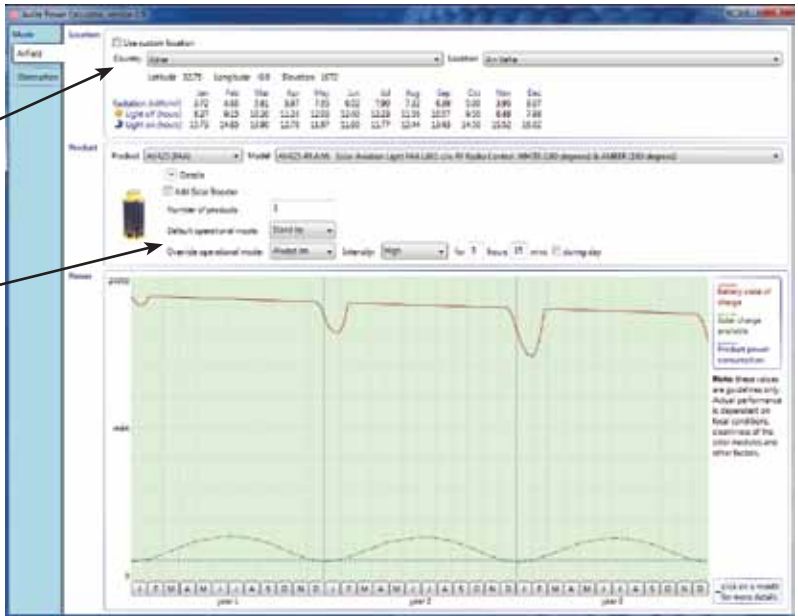

**Select location**

**Select usage profile**

| Month               | Jan   | Feb   | Mar   | Apr   | May   | Jun   | Jul   | Aug   | Sep   | Oct   | Nov   | Dec   |
|---------------------|-------|-------|-------|-------|-------|-------|-------|-------|-------|-------|-------|-------|
| Calculation (hours) | 13.12 | 14.68 | 16.61 | 18.67 | 17.25 | 16.22 | 15.90 | 17.61 | 18.88 | 17.88 | 14.99 | 11.27 |
| Light on (hours)    | 8.27  | 9.12  | 10.20 | 11.31 | 12.23 | 12.93 | 13.28 | 13.29 | 13.37 | 14.20 | 14.89 | 15.88 |
| Light on (hours)    | 13.75 | 14.89 | 15.80 | 15.75 | 15.87 | 15.89 | 15.79 | 15.14 | 14.63 | 14.50 | 12.92 | 10.82 |

**Important Note:** To ensure the battery is maintained in a healthy state of charge it is recommended that the light battery diagnostic check be performed once per day.

**Important Note:** Hours of Effective Sunlight are dependent upon the location in the world of the light. Effective hours alter with the seasons and this must be taken into account when setting up the Radio Control System.

Effective sunlight hours for various locations can be found at:  
[www.sealite.com.au/technical/solar\\_chart.php](http://www.sealite.com.au/technical/solar_chart.php)

**Important Note:** the AV425 is a solar-powered light fixture. It is the operator's responsibility to ensure usage demand does not exceed the charging capacity of the light fixture. Avlite holds no responsibility for product failure due to excessive usage demand.



## Simple Approach Lighting

The AV-425-RF-REIL-W can be configured into a simple approach lighting system. A simple approach lighting system is a lighting system intended for a non-instrument or a non-precision approach runway. This is done through selecting different sync delay or sync offset.

All lights must be in the same light group and the same REIL group. Sync option must be activated in the system menu. Flash code selected must be the same. Each individual light is then set with a sync delay or sync offset.

Please refer to **Radio Control System Setup**, Section 2, Programming the light using the cable interface and handheld controller, paragraph G or H on Sync offset and Sync Delay for information on how to set Sync Offset or Sync delay.



**The information contained in this publication is advisory only. Please contact your local authority for rules and regulations particular to your region.**

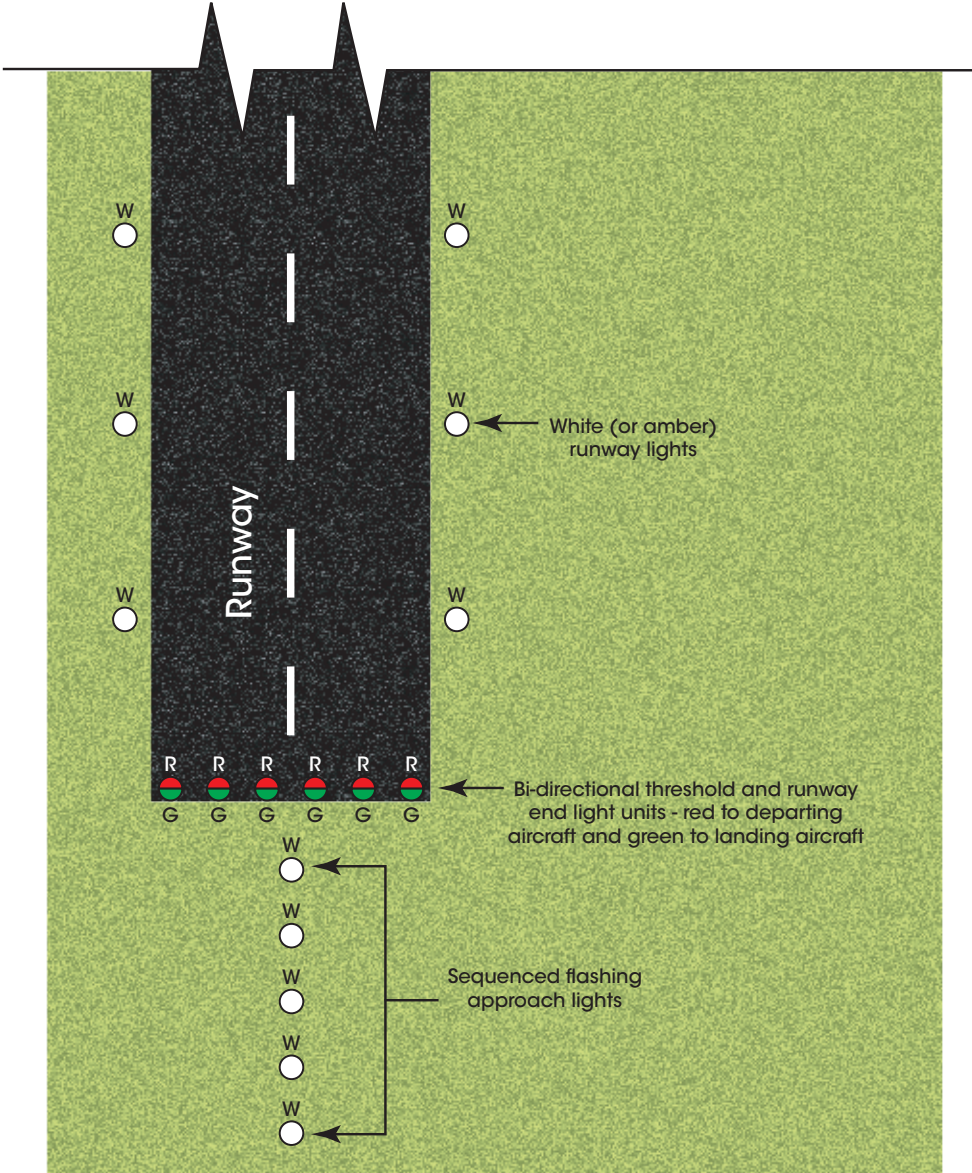



## Runway End Identifier Light (REIL)

The AV-425-RF is available in a REIL configuration. The AV-425-RF-REIL-W must be ordered preset from the factory. It is not possible to configure a REIL from a standard AV-425-RF runway edge light.

REILS will be pre-programmed and clearly labelled upon dispatch. REILS from the same light group and same REIL group must be installed together.

The recommended flash character for a REIL is 112 (120 FPM).

### Light groups

Light groups are used to enable control of separate sections of the airfield lighting system. For example, Runway 1, Runway 2, Taxiway, Obstruction and REILS can all be independently controlled by the ALS RF controller. This function allows the Air Traffic controller to turn on or off different sections of the airfield as required.

Please refer to **Radio Control System Setup**, Section 2, Programming the light using the cable interface and handheld controller, paragraph D on light groups for information on how to set a light group.

### REIL Groups

A REIL group is the group of lights that will flash in sync together. REILS from different REIL groups will not flash in sync together.

When installing 2 pairs of REILS on the airfield one pair at each end, it is advisable to ensure they are in different light groups and different REIL groups.



**The information contained in this publication is advisory only. Please contact your local authority for rules and regulations particular to your region.**

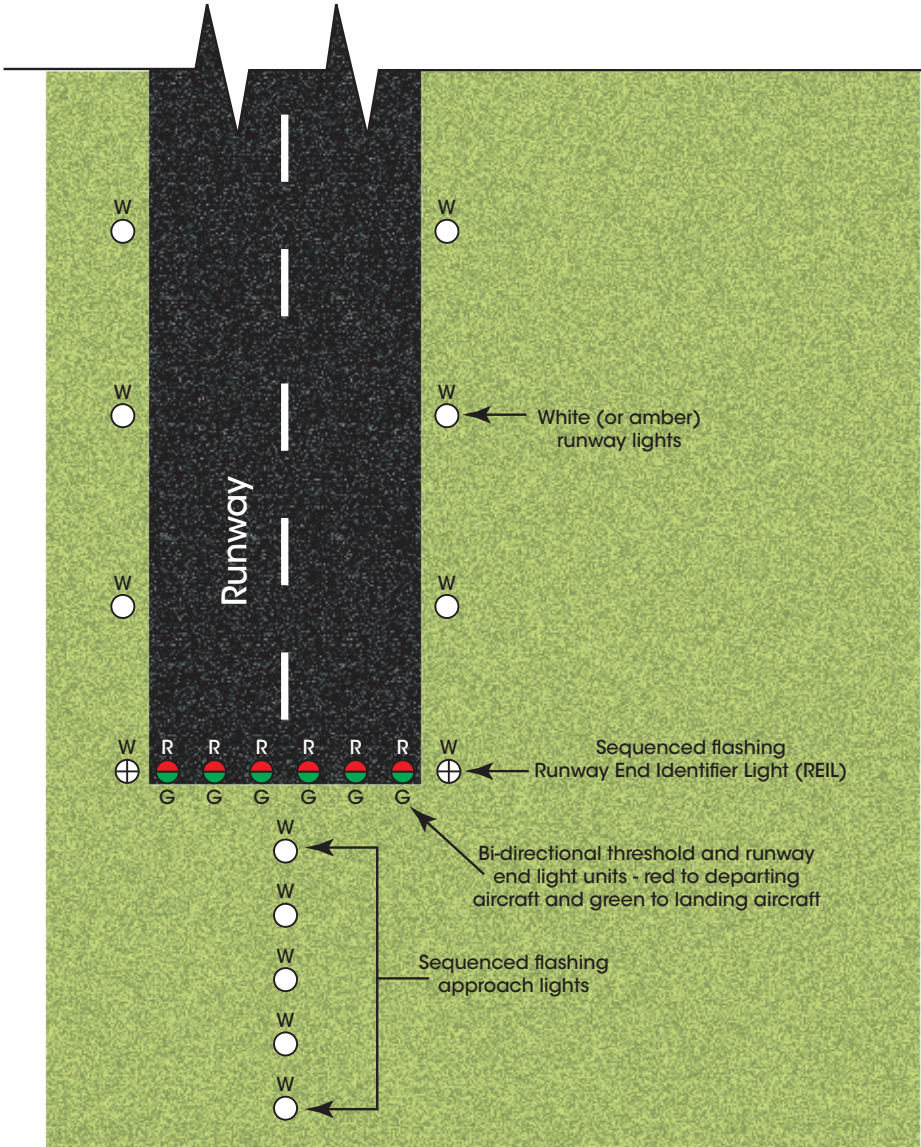





## Maintenance and Servicing

Designed to be almost maintenance-free, the AV-425-RF requires minimal attention, though the following maintenance and servicing information is provided to help ensure the life of your Avlite Systems product.

1. **Cleaning Solar Panels-** occasional cleaning of the solar panels may be required. Using a cloth and warm soapy water, wipe off any foreign matter before rinsing the panels with fresh water.
2. **Battery Check-** inspection of batteries should be performed every three years (minimum) to ensure that the charger, battery and ancillary electronics are functioning correctly. Using a voltage meter, check that the battery voltage is at least 12 volts under 100mA load, and ensure all terminals are clear of foreign matter.
3. **O-Ring Check-** inspect the condition of the o-ring for damage, wear or if it is brittle, and replace if necessary. The o-ring should be a rubber texture to ensure a complete and even seal.

### Service Tools

- 1 x M2 Allen Key
- 1 x M5 Allen Key
- 1 x 13mm Combination Wrench
- 1 x M8 Allen Key
- 1 x 10mm Combination Wrench
- 1 x Silicone Grease

### Replacement Part Numbers

- Complete Units: AV425-R/G  
AV425-W  
AV425-W/Y
- Light Head only: ALA-AV425-R/G  
ALA-AV425-W  
ALA-AV425-W/Y
- Solar Unit Only: ABA-AV425
- Test Lead: BTL-SLA.12v
- Battery Charger 12 volt: BTC-SLA.12v
- Solar Booster™: AV-SB-10

### Installing the Light Head Assembly on the Solar Unit

After servicing, it will be necessary to reinstall the light head on the solar unit.

1. Connect the 4 bullet connectors
2. Ensure the o-ring seal on the top of the solar chassis is in place, clean and lightly greased
3. Feed the wires into the corner of the solar unit
4. Locate the light head onto the solar unit in the correct orientation to the runway. The light head is fitted with reflective tape indicators to show light output. This colour indication should be aligned with the colour indication on the solar unit to ensure correct alignment.
5. Fit the 4 x M6 x 20 SHCS
6. Tighten the SHCS evenly and firmly.

Recommended torque settings for Fitment of Light Heads to Solar Base units using the 4 Hex Bolts supplied. It is recommended that the bolts for holding the light heads to the Solar Base units have a torque setting applied of 3Nm for a satisfactory seal.

Applying a higher Torque setting is not recommended and may void warranty. If in doubt, please contact your local Avlite representative.

7. Remove all tools, nuts and bolts from the runway



## Replacing the Battery

The AV-425-RF has an internal battery compartment, which provides the user with the ability to change the battery after years of operation.

1. Remove the four socket-head screws on the top lens assembly and separate the AV-425-RF lens assembly from the body/base section.
2. Remove 2 x M4 SHCS & washers from the top battery bracket.
3. Remove the 2 x M5 Nylock nuts and washers from the top battery bracket.
4. Separate the light head at the connectors.
5. Lift the upper battery bracket out of the AV-425-RF.
6. Disconnect the old battery
7. Remove the old battery from the chassis.
8. Discard old battery in a safe manner.
9. Reconnect the new battery.
10. Place battery back inside light body, and position the upper battery bracket in the top of the chassis.
11. Secure using 2 x M4 Cap screws & washers and 2 x M5 Nylock nuts and washers.
12. Feed all wiring back inside light body, and make sure the o-ring is properly placed at the top of the light body.
12. Please realign bidirectional indicators on the base with the light head to ensure correct alignment of the light output on the runway.
13. Place the top lens assembly back onto the light body and replace 4 socket head screws. Half tighten all 4 socket head screws, and then fully tighten each socket head screw to ensure an even seal.  
Recommended torque settings for Fitment of Light Heads to Solar Base units using the 4 Hex Bolts supplied. It is recommended that the bolts for holding the light heads to the Solar Base units have a torque setting applied of 3Nm for a satisfactory seal.  
Applying a higher Torque setting is not recommended and may void warranty. If in doubt, please contact your local Avlite representative.
14. To test place dark cover (towel or jacket) on top of light to activate sensor, light will come on.

***Care must be taken to observe the polarity of each wire before they are connected.  
To ensure waterproofing of the unit, make sure that there is an even seal.***

## AV-425-RF Long Term Battery Storage & Maintenance

If the AV-425-RF is to be placed in storage for an extended period please follow the below information.

The Sealed Lead Acid batteries inside the lights must always be stored in a fully charged state.

Always make sure the ON/OFF switch is in the OFF position.

All batteries will discharge over time and the rate of discharge is dependent on temperature.

If the light is being stored in temperatures greater than 40°C the battery will discharge faster.

Please check battery regularly and recharge if necessary, charge the battery via the external charging port on the base of the unit. Only attach the plug with your hand, do not use multi-grips to attach the plug.

Turn the ON/OFF switch to the ON position and place unit in the sun for 2-4 days.

The AV-425-RF is fitted with a 12 volt charge port that can be used to charge the battery and test the battery voltage.

Connect the test lead (Avlite Part Number BTL-SLA.12v) to a multimeter on volts.





## **Safe Battery Handling**

### **Charging and Discharging**

- Always ensure batteries are fully charged when installing new lights. The light will be dispatched from the Avlite factory fully charged. However if time has elapsed between dispatch and installation, battery voltage must be checked.
- Never short-circuit or reverse polarity a battery, damage to the battery and device may occur, and there is a risk of fire.
- Do not use different types of batteries in the same battery assembly. Sealed lead acid and NIMH do not mix.
- If the battery has been deep-discharged, a prolonged charging time is required to bring the battery back to full capacity.

### **Storage**

- Always store batteries in a cool, dry place.
- After long storage, it is desirable to cycle (charge/discharge) the battery 3 times to restore full capacity.
- Do not mix batteries with metal objects during storage or transportation to avoid accidental short-circuit.
- Do not store large quantities of batteries in a densely packed condition when they are in a charged or partially charged state.

### **Battery Handling**

- Do not incinerate or dismantle batteries. Cell components are corrosive and may be harmful to skin and eyes.
- Do not pull on battery lead wires or connector. Excessive force on the leads or connectors can damage the welding joints or other connections.
- Batteries are recyclable. Please dispose of properly.



**Battery Voltage States of Charge**

Avlite has provided the following guides for battery states of charge:

| <b>Battery Voltage: 12 Volt Sealed Lead Acid</b> |                |
|--|----------------|
| <b>State of Charge</b>                           | <b>Voltage</b> |
| 100%   | 12.70+         |
| 90%  | 12.5           |
| 80%  | 12.42          |
| 70%  | 12.32          |
| 60%  | 12.2           |
| 50%  | 12.05          |
| 40%  | 11.9           |
| 30%  | 11.75          |
| 20%  | 11.58          |
| 10%  | 11.31          |
| 0%   | 10.5           |

## Solar Panel Replacement

The AV-425-RF is built around an internal aluminium chassis.

The solar panels can be user-replaced, by a trained technician, in the unlikely event that one is broken or damaged during the product life (as demonstrated below).

Follow the steps below or contact support@avlite.com for more details.



1. Remove 4 x socket head cap screws and disconnect the light head from the chassis.
2. Remove the upper battery bracket.
3. Disconnect the battery.
4. Remove the battery.

5. Remove 4 x M6-35mm long socket head cap screws, to remove the top casting from the chassis.

**Note:**

Be careful not to damage the o-rings on each of these screws.  
If replacements are required please use standard 6x1.0mm o-ring.

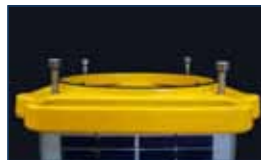

6. Slide the rubber corner out of the chassis. It may be necessary to lubricate the edges of the solar panels with grease or oil based lubricant if this is difficult to remove.
7. Disconnect the faulty solar panel from the Auxiliary Power out, J5, J6, J7 or J8.
8. Remove the faulty solar panel from the aluminium chassis.

9. Clean any silicon off the chassis from the solar panel junction box hole and add a new silicone seal to ensure the solar panel is watertight when assembled.

10. Repeat the process in the reverse order to replace a new panel.

**Note:**

Make sure the O-rings on the top casting and 4 x M6-35mm long socket head cap screws are coated in silicon grease before re-assembling.

Recommended torque settings for Fitment of Light Heads to Solar Base units using the 4 Hex Bolts supplied. It is recommended that the bolts for holding the light heads to the Solar Base units have a torque setting applied of 3Nm for a satisfactory seal.

Applying a higher Torque setting is not recommended and may void warranty. If in doubt, please contact your local Avlite representative.



**The replacement of a solar panel should only be performed by a confident technician.**

*Solar panel replacement is undertaken at customer's own risk. Avlite will only guarantee an IP68 rating if this is undertaken by Avlite Personnel.*

To test for any leaks remove the gore vent and pressurise the assembled light to 1.5psi.

## Trouble Shooting

| Fault   | Possible Cause   | Remedy  |
|---|--|---|
| <b>Light will not respond to controller in Radio Control Mode</b> |  |   |
|   | Different encryption key in the light from the controller    | Reenter the encryption key into the light using the direct connection. See Programming - Section 1  |
|   | Different radio channel in the light from the controller     | Check the radio channel in the light using the direct connection is the same as the controller.   |
|   | Encryption turned off in the controller but not in the light | Turn encryption On and set encryption key in the controller and all the lights  |
|   | Incorrect Light bank selected                                | Ensure that the light bank selected in the controller is the same as the light bank settings in the lights  |
| <b>Light will not change between visible and IR/NVG modes</b>     | Advanced Operation not enabled                               | Enable Advanced operation Mode in the Radio Control System Menu. See Programming - Section 1  |
| <b>Light will not change Flash Codes</b>                          | Flash Codes not enabled in the Radio Control System Menu     | Enable Flash Codes in the Radio Control System Menu. See Programming- Section 1   |
| <b>Sync delay not available</b>                                   | Sync not enabled in the Radio Control System Menu            | Enable Sync in the radio Control Menu. See Programming- Section 1   |
| <b>Light will not activate</b>                                    | Battery is flat  | Recharge Battery or connect light to external power supply  |
|   | Light is not switched ON at the master switch                | Switch light on at the Red Master Switch on the I/O panel   |
| <b>Lights will not activate during the Day</b>                    | Light is set to Dusk till Dawn and it is not dark            | Cover the light for at least 60 seconds of continuous darkness for the light to activate  |
|   |  | To activate lights during the day, temporarily change the light settings to Always On. Important: Lights must be turned back to Dusk till Dawn or Standby after required daytime use. |
| <b>Light will not activate at night</b>                           | Light is in Standby Mode                                     | Using the Remote control change light to the Dusk till Dawn   |
|   | Light is not switched on at the master switch                | Switch light on at the Red Master Switch on the I/O panel   |

| <b>Fault</b>                            | <b>Possible Cause</b>             | <b>Remedy</b>   |
|---|-----------------------------------|---|
| <b>Light will not operate all night</b> | Battery is low                    | Recharge battery, connect battery to external power supply or replace battery |
|   | Light is exposed to ambient light | Remove ambient light source or shield light from ambient light                |
| <b>Battery continually goes flat</b>    | Battery has failed                | Replace battery   |
|   | Solar panels are dirty            | Clean solar panels  |
|   | Light is installed in the shade   | Remove shade or move light  |



## Documentation

For future reference, please record the following data and store securely:

**Controller Encryption Key:** \_\_\_\_\_

**Controller Serial No.:** \_\_\_\_\_

**Radio Channel:** \_\_\_\_\_

**Light Bank Location, eg. Runway 1, Taxiway, Runway 2:**

Light Bank Location 0: \_\_\_\_\_

Light Bank Location 1: \_\_\_\_\_

Light Bank Location 2: \_\_\_\_\_

Light Bank Location 3: \_\_\_\_\_





## **AV-SB-10 Solar Booster™**

*The AV-SB-10 Solar Booster™ can be connected to AV425 light to provide additional solar collection to charge the battery. The Solar Booster™ can be used in areas of reduced sunlight to help ensure optimum battery charge or where longer periods of high intensity mode is required.*

*The solar panel is connected to the light via the external charge port and the panel is mounted at an angle to maximise solar collection during daylight hours.*

*The solar Booster™ will provide up to 0.5Ah of additional charge into the battery.*

*In areas of high solar conditions, this may allow the fixture to operate in a high-intensity L-861 output setting for up to 11hrs per night.*

*In lower solar regions, fitting the Solar Booster™ may widen the operating latitudes where the standard AV425 may not be sufficient.*

*For detailed solar profiling of your region please contact Avlite Systems.*



**SPECIFICATIONS \* \***

**AV-SB-10**

**Electrical Characteristics**

|                   |             |
|-------------------|-------------|
| Voltage (v)       | 12          |
| Amperage (mA)     | 580         |
| Temperature Range | -40 to 80°C |

**Solar Characteristics**

|                             |                           |
|-----------------------------|---------------------------|
| Solar Module Type           | Multicrystalline          |
| Output (watts)              | 10                        |
| Solar Module Efficiency (%) | 14                        |
| Charging Regulation         | Microprocessor controlled |

**Physical Characteristics**

|                         |                                 |
|-------------------------|---------------------------------|
| Body Material           | 7-stage powder-coated aluminium |
| Mounting                | 4 hole 200mm bolt pattern       |
| Height (mm/inches)      | 150 / 5 7/8                     |
| Width (mm/inches)       | 370 / 14 1/2                    |
| Length (mm/inches)      | 560 / 22                        |
| Mass (kg/lbs)           | 3.2 / 7                         |
| Product Life Expectancy | Up to 12 years                  |

**Certifications**

|                   |                                    |
|-------------------|------------------------------------|
| CE                | EN61000-6-3:1997. EN61000-6-1:1997 |
| Quality Assurance | ISO9001:2008                       |
| Waterproof        | IP68                               |

**Intellectual Property**

|                   |  |
|-------------------|--|
| Trademarks        | Solar Booster™ is a registered trademark of Avlite Systems |
| <b>Warranty *</b> | 3 year warranty  |

- Specifications subject to change or variation without notice
- \* Subject to standard terms and conditions



**AV-SB-10 Solar Booster™**  
shown with AV-425-RF



## Solar Booster™ Installation Procedure

### Preferred Installation Location

*For best light performance, ensure solar modules are not covered and are in clear view of the sky with no shadows.*

Remove the AV-SB-10 from the box and remove all packaging.

Locate the AV-SB-10 Solar Booster™, in a position for best solar collection.

Remove the bolts from the existing installation. Fit the AV-SB-10 Solar Booster™ under the top mounting plate. Fit the bolts back through the light, mounting plate and AV-SB-10 Solar Booster™. Tighten the bolts securely.

**Important: To eliminate the possibility of electrical shorts please read this before connecting the AV-SB-10 Solar Booster™ to the light**

Remove the Light head from the unit. Remove the fuse from the battery positive wire.

Connect the AV-SB-10 Solar Booster™ to the external charge port on the light.

Refit the fuse to the battery positive wire and refit the light head.

Cover the light head to ensure that light activates.



AV-SB-10 Solar Booster™ front view

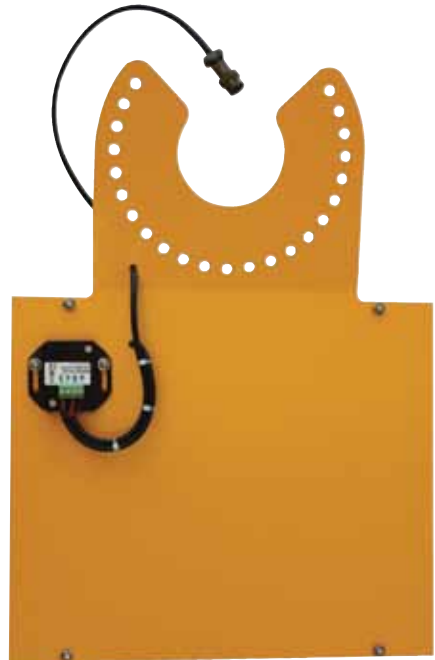

AV-SB-10 Solar Booster™ rear view



## Notes



## Avlite Light Warranty V1.2

### Activating the Warranty

Upon purchase, the Avlite Systems warranty must be activated for recognition of future claims. To do this you need to register on-line. Please complete the Online Registration Form at:

[www.avlite.com](http://www.avlite.com)

***Avlite Systems will repair or replace your lantern in the event of electronic failure for a period of up to three years from the date of purchase.***

***Avlite Systems will repair or replace any ancillary or accessory products in the event of failure for a period of up to one year from the date of purchase, as per the terms & conditions below.***

***The unit must be returned to Avlite freight prepaid.***

### Warranty Terms

1. Avlite Systems warrants that any Avlite aviation products fitted with telemetry equipment including but not limited to AIS, GSM, GPS or RF ("Telemetry Products") will be free from defective materials and workmanship under normal and intended use, subject to the conditions hereinafter set forth, for a period of twelve (12) months from the date of purchase by the original purchaser.
2. Avlite Systems warrants that any rotationally-moulded products ("Roto-Moulded Products") and accessory products ("Accessory Products") will be free from defective materials and workmanship under normal and intended use, subject to the conditions hereinafter set forth, for a period of twelve (12) months from the date of purchase by the original purchaser.
3. Avlite Systems warrants that any Avlite aviation products other than the Telemetry Products, Roto-Moulded Products and Accessory Products ("Avlite Products") will be free from defective materials and workmanship under normal and intended use, subject to the conditions hereinafter set forth, for a period of three (3) years from the date of purchase by the original purchaser.
4. Avlite Systems will repair or replace, at Avlite's sole discretion, any Telemetry Products, Roto-Moulded Products, Accessory Products or Avlite Products found to be defective in material and workmanship in the relevant warranty period so long as the Warranty Conditions (set out below) are satisfied.
5. If any Telemetry Products or Avlite Products are fitted with a rechargeable battery, Avlite Systems warrants the battery will be free from defect for a period of one (1) year when used within original manufacturer's specifications and instructions.

### Warranty Conditions

This Warranty is subject to the following conditions and limitations;

1. The warranty is applicable to lanterns manufactured from 1/1/2009.
2. The warranty is void and inapplicable if:
  - a. the product has been used or handled other than in accordance with the instructions in the owner's manual and any other information or instructions provided to the customer by Avlite;
  - b. the product has been deliberately abused, or misused, damaged by accident or neglect or in being transported; or
  - c. the defect is due to the product being repaired or tampered with by anyone other than Avlite or authorised Avlite repair personnel.
3. The customer must give Avlite Systems notice of any defect with the product within 30 days of the customer becoming aware of the defect.
4. Rechargeable batteries have a limited number of charge cycles and may eventually need to be replaced. Typical battery replacement period is 3-4 years. Long term exposure to high temperatures will shorten the battery life. Batteries used or stored in a manner inconsistent with the manufacturer's specifications and instructions shall not be covered by this warranty.
5. No modifications to the original specifications determined by Avlite shall be made without written approval of Avlite Systems.
6. Avlite lights can be fitted with 3rd party power supplies and accessories but are covered by the 3rd



- party warranty terms and conditions.
7. The product must be packed and returned to Avlite Systems by the customer at his or her sole expense. Avlite Systems will pay return freight of its choice. A returned product must be accompanied by a written description of the defect and a photocopy of the original purchase receipt. This receipt must clearly list model and serial number, the date of purchase, the name and address of the purchaser and authorised dealer and the price paid by the purchaser. On receipt of the product, Avlite Systems will assess the product and advise the customer as to whether the claimed defect is covered by this warranty.
  8. Avlite Systems reserves the right to modify the design of any product without obligation to purchasers of previously manufactured products and to change the prices or specifications of any product without notice or obligation to any person.
  9. Input voltage shall not exceed those recommended for the product.
  10. Warranty does not cover damage caused by the incorrect replacement of battery in solar lantern models.
  11. This warranty does not cover any damage or defect caused to any product as a result of water flooding or any other acts of nature.
  12. There are no representations or warranties of any kind by Avlite or any other person who is an agent, employee, or other representative or affiliate of Avlite, express or implied, with respect to condition of performance of any product, their merchantability, or fitness for a particular purpose, or with respect to any other matter relating to any products.

### **Limitation of Liability**

To the extent permitted by acts and regulations applicable in the country of manufacture, the liability of Avlite Systems under this Warranty will be, at the option of Avlite Systems, limited to either the replacement or repair of any defective product covered by this Warranty. Avlite Systems will not be liable to Buyer for consequential damages resulting from any defect or deficiencies in accepted items.

### **Limited to Original Purchaser**

This Warranty is for the sole benefit of the original purchaser of the covered product and shall not extend to any subsequent purchaser of the product.

### **Miscellaneous**

Apart from the specific warranties provided under this warranty, all other express or implied warranties relating to the above product is hereby excluded to the fullest extent allowable under law. The warranty does not extend to any lost profits, loss of good will or any indirect, incidental or consequential costs or damages or losses incurred by the purchaser as a result of any defect with the covered product.

### **Warrantor**

Avlite Systems has authorised distribution in many countries of the world. In each country, the authorised importing distributor has accepted the responsibility for warranty of products sold by distributor. Warranty service should normally be obtained from the importing distributor from whom you purchased your product. In the event of service required beyond the capability of the importer, Avlite Systems will fulfil the conditions of the warranty. Such product must be returned at the owner's expense to the Avlite Systems factory, together with a photocopy of the bill of sale for that product, a detailed description of the problem, and any information necessary for return shipment.

**Other Avlite Products Available**



**Solar Aviation Lighting**



**Helipad Lighting**



**Obstruction Lighting**



**Airfield Markers & Accessories**

**Typical Applications**

- Temporary & permanent airfield lighting
- Remote, emergency & defence airfield lighting
- Barricade, hazard & perimeter lighting
- Helipad lighting
- Obstruction lighting

For a complete list of product compliances including ICAO & FAA, please contact Avlite today



**Area & Sign Lighting**

**Avlite Systems**

11 Industrial Drive  
Somerville Vic 3912  
AUSTRALIA

t: +61 (0)3 5977 6128  
f: +61 (0)3 5977 6124

61 Business Park Drive  
Tilton New Hampshire  
03276 USA

t: +1 (603) 737 1311  
f: +1 (603) 737 1320

**e:** info@avlite.com **w:** www.avlite.com

A subsidiary of Sealite Pty Ltd www.sealite.com

