

Solar Aviation Light

AV-70

Features

- Integrated solar/battery system
- Dual internal high-performance solar modules angled to maximize solar collection
- Fast & easy to deploy - no programming
- IP68 waterproof rating
- User-replaceable battery
- Ultra-high intensity LEDs (no changing globes ever)

Typical Applications

- Solar Barricade Light
- Solar Caution Light
- Solar Taxiway Light (ICAO)
- Solar Threshold Light
- Solar Obstruction Light

Compliance

- FAA AC150/5370-2F for construction and barricade installations
- ICAO Annex 14 Volume 1, 'Aerodrome Design and Operations', paragraph 5.3.17.7.



Royal Flying Doctor Service

Avlite donates AU\$20 to the Royal Flying Doctor Service from the sale of each AV-60 & AV-70 light within Australia

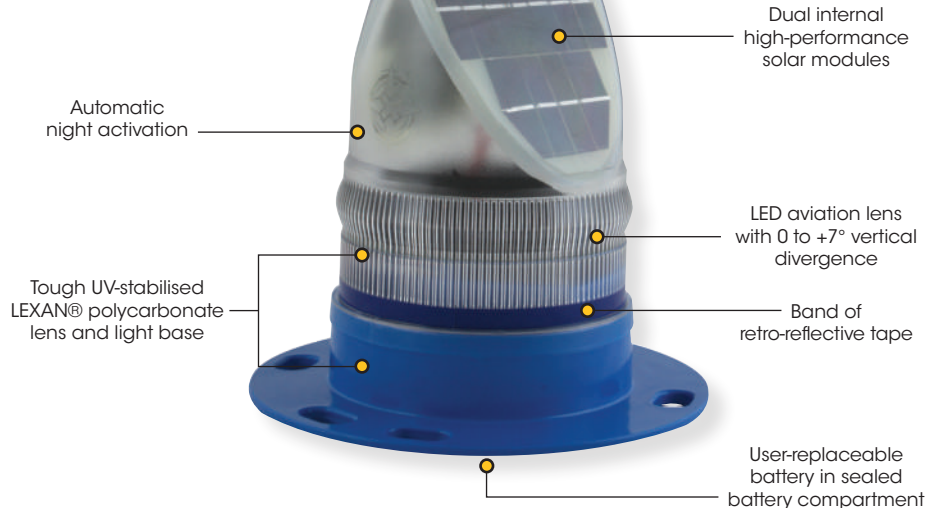
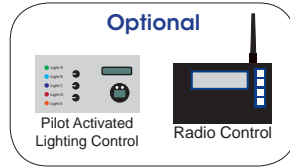

The solar powered AV-70 is a field proven aviation light that offers enormous benefits over traditional battery and hard-wired aviation lights including low maintenance and no underground wiring.

These completely self-contained LED lights are designed to suit a range of aviation and general applications including emergency airstrip, caution, taxiway, and threshold lighting.

The unit has two high-performance solar modules mounted within the lens, which maximize solar collection and provide reliable operation in a range of environmental conditions.

The focal plane of the light is designed to provide a vertical divergence of between 0 and +7 degrees, and the user-replaceable battery ensures a service life of up to 12 years.

The AV-70 is made from tough, durable UV stabilized LEXAN® polycarbonate, and incorporates an internal photodiode for automatic night activation once the ambient light threshold drops sufficiently.

Completely self-contained and able to be installed in minutes, the AV-70 is the preferred choice of remote airfields throughout Australia - where the units mark indigenous and regional council's airstrips, and mining strips around the country.

AV-70-HI

The AV-70-HI is a high intensity version of the popular AV-70 and is ideal for use in high sunlight areas that receive a minimum of 3.5 hours of sun per day.

Optional Radio Control

The AV-70-RF is a radio-controlled version of the popular AV-70, which can be used in conjunction with a PALC or simple handheld controller. Users can wirelessly control ON/OFF functions, adjust light intensities or switch between visual and IR (tactical) operational modes.

The AV-SB-3 Solar Booster™ can be connected to the AV-70 light to provide additional solar collection for charging the battery. The Avlite Solar Booster™ can be used in areas of reduced sunlight to help ensure optimum battery charge.

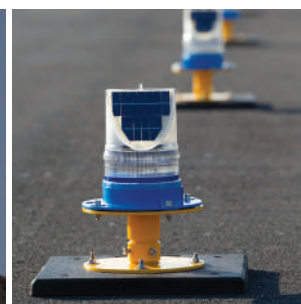
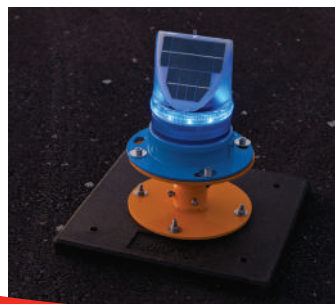
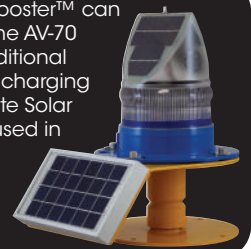

SPECIFICATIONS* *	AV-70	AV-70-HI
Light Characteristics		
Light Source	12 ultra-high intensity LEDs	12 ultra-high intensity LEDs
Available colors	Red, Green, White, Yellow, Amber, Blue, Sectored Combinations	Red, Green, White, Yellow, Amber, Blue, Sectored Combinations
Peak Intensity (cd) †	Steady-on: Blue - 2.8 Red - 6.8 Green - 9.0 White - 7.0 Yellow - 6.5 Flashing: Blue - 5.5 Red - 18.2 Green - 21.9 White - 19.1 Yellow - 15.1	Steady-on: Blue - 4.5 Red - 12.1 Green - 16.9 White - 14.2 Yellow - 11.6 Flashing: Not available
Horizontal Output (degrees)	360	360
Vertical Divergence (degrees)	0 to +7	0 to +7
Reflector Type	Omnidirectional 360° LED Reflector (US Pat. No. 6,667,582, AU Pat. No. 778,918)	Omnidirectional 360° LED Reflector (US Pat. No. 6,667,582, AU Pat. No. 778,918)
Available Flash Characteristics	>250 including steady-on (user-adjustable)	Not available
Intensity Adjustments	Adjustable in 25% increments	Adjustable in 25% increments
LED Life Expectancy (hours)	>100,000	>100,000
Electrical Characteristics		
Operating Voltage (V)	3.6	3.6
Temperature Range	-40 to 80°C	-40 to 80°C
Solar Characteristics		
Solar Module Type	Multicrystalline	Multicrystalline
Output (watts)	2.5 (2 x 1.25watt)	2.5 (2 x 1.25watt)
Solar Module Efficiency (%)	14	14
Charging Regulation	Microprocessor controlled	Microprocessor controlled
Power Supply		
Battery Type	High grade NiMH - Environmentally friendly	High grade NiMH - Environmentally friendly
Battery Capacity (Ah)	8	16
Nominal Voltage (V)	3.6	3.6
Autonomy (nights)	Steady-on: >14 Flashing: >38 (14 hour darkness, 12.5% duty cycle)	Steady-on: >19 Flashing: Not available
Radio Controlled (optional)		
Frequency	2.4GHz ISM Band	2.4GHz ISM Band
Range	Up to 1.4km relayed	Up to 1.4km relayed
Expandability	AvMesh®	AvMesh®
Compliance	FCC / CE	FCC / CE
Physical Characteristics		
Body Material	LEXAN® Polycarbonate - UV stabilized	LEXAN® Polycarbonate - UV stabilized
Lens Material	LEXAN® Polycarbonate - UV stabilized	LEXAN® Polycarbonate - UV stabilized
Lens Diameter (mm/inches)	140 / 5½	140 / 5½
Lens Design	External optics with interior flute design	External optics with interior flute design
Mounting	6 x 17mm holes on 200mm PCD	6 x 17mm holes on 200mm PCD
Height (mm/inches)	240 / 9½	240 / 9½
Width (mm/inches)	231 / 9¼	231 / 9¼
Mass (kg/lbs)	1.1 / 2½	1.41 / 3¼
Product Life Expectancy	Up to 12 years	Up to 12 years
Environmental Factors		
Humidity	0 to 100%, MIL-STD-810F	0 to 100%, MIL-STD-810F
Icing	22kg per square inch	22kg per square inch
Wind Speed	Up to 160kph	Up to 160kph
Shock	MIL-STD-202G, Test Condition G, Method 213B	MIL-STD-202G, Test Condition G, Method 213B
Vibration	MIL-STD202G, Test Condition B, Method 204	MIL-STD202G, Test Condition B, Method 204
Certifications		
CE	EN61000-6-3:1997, EN61000-6-1:1997	EN61000-6-3:1997, EN61000-6-1:1997
Quality Assurance	ISO9001:2008	ISO9001:2008
Waterproof	IP68	IP68
Intellectual Property		
Patents	US Pat. No. 6,667,582, AU Pat. No. 778,918	US Pat. No. 6,667,582, AU Pat. No. 778,918
Trademarks	AVLITE® is a registered trademark of Avlite Systems	AVLITE® is a registered trademark of Avlite Systems
Warranty *	3 year warranty	3 year warranty
Options Available	<ul style="list-style-type: none"> Radio Controlled - FCC compliant Avlite Pilot Activated Lighting Control IR LEDs External ON/OFF Switch External Battery Charging Port Manual Operation Solar Booster™ 	<ul style="list-style-type: none"> Radio Controlled - FCC compliant Avlite Pilot Activated Lighting Control IR LEDs External ON/OFF Switch External Battery Charging Port Manual Operation Solar Booster™

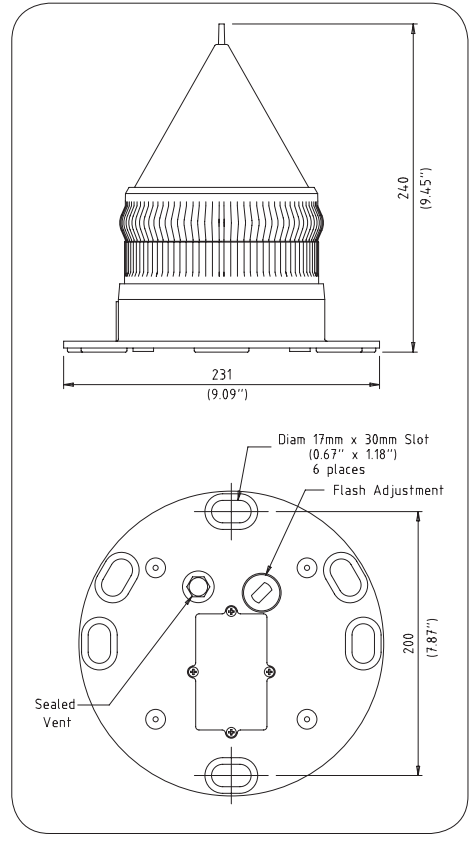
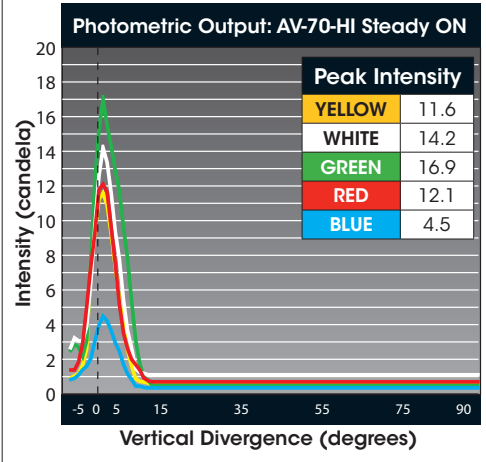
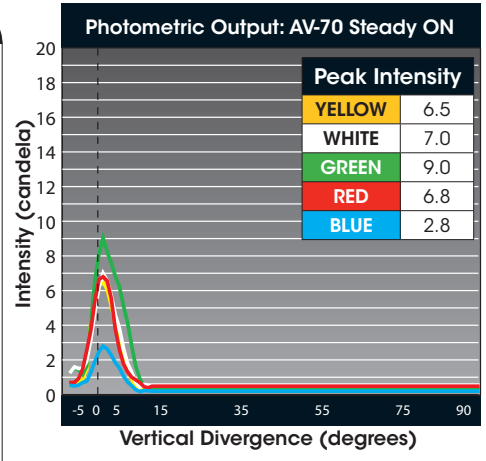

* Specifications subject to change or variation without notice
 † Subject to standard terms and conditions
 ‡ Intensity setting subject to solar availability



Avlite Systems
 AUSTRALIA t: +61 (0)3 5977 6128
 USA t: +1 (603) 737 1310

w: www.avlite.com
 e: info@avlite.com





AV-70 & AV-70-HI
Solar Aviation Light
Installation & Service Manual

AV-70 & AV-70-HI

Solar Aviation Light

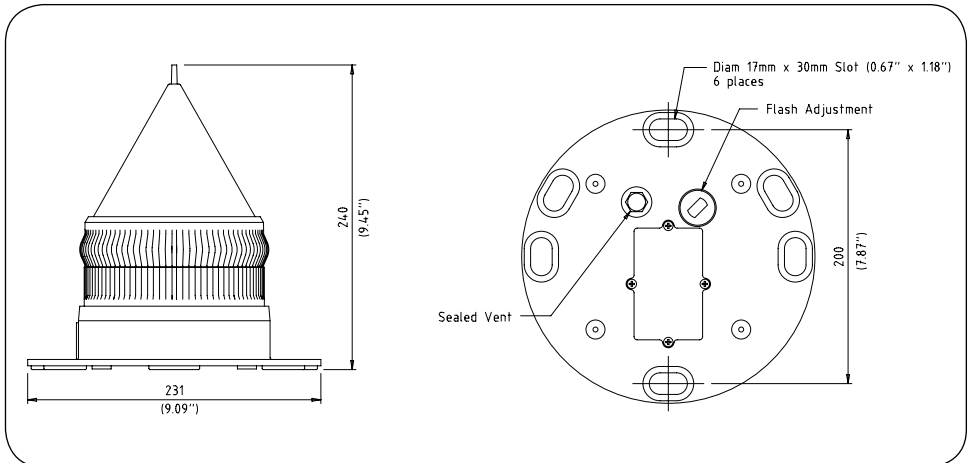
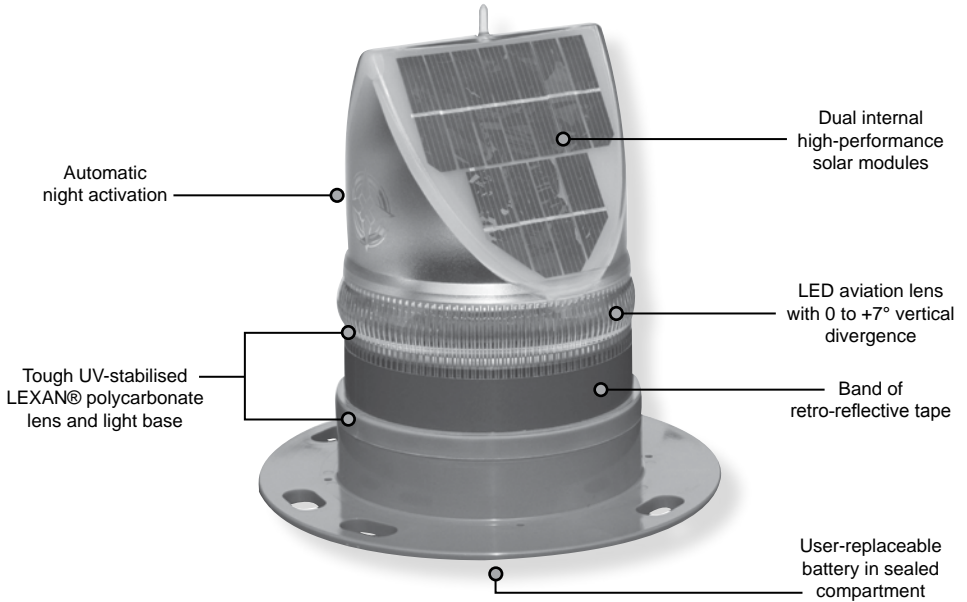

Table of Contents

Introduction	Page 4
Operating Principle	Page 4
Technology	Page 4
AV-70 Model	Page 5
AV-70-HI Model	Page 5
Installation	Page 8
Selecting an Intensity/Power Setting	Page 9
Selecting a Flash Code	Page 9
Flash Codes	Page 10
Installing the Light Assembly: Mounting Options	Page 15
Maintenance and Servicing	Page 19
Troubleshooting	Page 20
Avlite Light Warranty	Page 22

Version No.	Description	Date	Approved
3.2	Update: AV-70-HI added	May 2010	K. Paton
4.0	Update: Quality Logo	May 2011	P. Rainey
4.1	General Update	June 2012	J. Dore
5.0	Update: Spec table & Code	January 2013	J. Dore



Introduction

Congratulations! By choosing to purchase an Avlite light, you have become the owner of one of the most advanced solar LED airfield lights in the world.

Avlite Systems draws on more than 25 years experience in the design and manufacture of navigation aids, and particular care has been taken to ensure your light gives years of trouble free service.

As a commitment to producing the highest quality products for our customers, Avlite has been independently certified as complying with the requirements of ISO 9001:2008 quality management system.

By taking a few moments to browse through this booklet, you will become familiar with the versatility of your light, and be able to maximise its operating function.

Please remember to complete the Avlite warranty registration card accompanying your light.

Operating Principle

The solar module of the light converts sunlight to an electrical current that is used to charge the battery. The battery provides power to operate the light at night.

The flasher unit has very low current requirements. A microprocessor drives an array of ultra bright LED's through a DC/DC converter, which enables the LED's to operate within the manufacturer's specifications. The battery is protected from over-charging within the circuit to ensure maximum battery life.

On darkness, the microprocessor will initiate a program check and after approximately 1 minute will turn on.

Technology

Avlite Systems is a world-class solar lighting systems manufacturer with a proven reputation for rapid, innovative, and agile technology solutions designed specifically for defense, government, civil and humanitarian aid operations in the most remote, toughest environments.

Electronics

Avlite employs leading in-house electronic engineers in the design and development of software and related circuitry. All individual electronic components are sourced directly by Avlite procurement staff ensuring that only the highest quality components are used in our products.

LED Technology

All aviation lights use the latest advancements in LED (Light Emitting Diode) technology as a light source. The major advantage of LED's over traditional light sources is well established in that they typically have an operational life in excess of 100,000 hours, resulting in substantial savings to maintenance and servicing costs.

Precision Construction

Commitment to investing in the design and construction of injection-moulded parts including optic lenses, light bases and a range of other components ensures that all Avlite products are of a consistent and superior quality.

Optical Performance

Avlite manufactures a range of aviation LED lenses moulded from multi-cavity dies. Complex shapes such as the AV-70 and 16-segment multi-focus lenses are a testament to the company's superior in-house lens manufacturing capabilities and outstanding optical performance.

Award-winning, Patented Technology

Several United States and Australian patent registrations are held on Avlite's range of innovative designs, with other regional patents pending in Canada, United Kingdom and Europe.



AV-70 Model

The Avlite AV-70 solar airfield light is exceptional in its unique ability to 'track the sun', operating reliably in low sunlight conditions. Made from tough, durable polycarbonate and using the latest high-intensity LED's, the AV-70 light boasts dual high-performance solar modules incorporated into Avlite's world-first Solar Collection Lens.

AV-70-HI Model

The AV-70-HI is a high intensity version of the popular AV-70 and is ideal for use in high sunlight areas that receive a minimum of 3.5 hours of sun per day.



SPECIFICATIONS*

AV-70

Light Characteristics

Light Source
Available colors
Peak Intensity (cd) †

Horizontal Output (degrees)
Vertical Divergence (degrees)
Reflector Type

Available Flash Characteristics
Intensity Adjustments
LED Life Expectancy (hours)

Electrical Characteristics

Operating Voltage (V)
Temperature Range

Solar Characteristics

Solar Module Type
Output (watts)
Solar Module Efficiency (%)
Charging Regulation

Power Supply

Battery Type
Battery Capacity (Ah)
Nominal Voltage (V)
Autonomy (nights)

Radio Controlled (optional)

Frequency
Range
Expandability
Compliance

Physical Characteristics

Body Material
Lens Material
Lens Diameter (mm/inches)
Lens Design
Mounting
Height (mm/inches)
Width (mm/inches)
Mass (kg/lbs)
Product Life Expectancy

Environmental Factors

Humidity
Icing
Wind Speed
Shock
Vibration

Certifications

CE
Quality Assurance
Waterproof

Intellectual Property

Patents

Trademarks

Warranty *

Options Available

12 ultra-high intensity LEDs
Red, Green, White, Yellow, Amber, Blue, Sectored Combinations
Steady-on: Blue - 2.8 Red - 6.8 Green - 9.0 White - 7.0 Yellow - 6.5
Flashing: Blue - 5.5 Red - 18.2 Green - 21.9 White - 19.1 Yellow - 15.1
360
0 to +7
Omnidirectional 360° LED Reflector (US Pat. No. 6,667,582.
AU Pat. No. 778,918)
>250 including steady-on (user-adjustable)
Adjustable in 25% increments
>100,000

3.6
-40 to 80°C

Multicrystalline
2.5 (2 x 1.25watt)
14
Microprocessor controlled

High grade NiMH - Environmentally friendly
8
3.6
Steady-on: >14
Flashing: >38 (14 hour darkness, 12.5% duty cycle)

2.4GHz ISM Band
Up to 1.4km relayed
AvMesh®
FCC / CE

LEXAN® Polycarbonate - UV stabilized
LEXAN® Polycarbonate - UV stabilized
140 / 5½
External optics with interior flute design
6 x 17mm holes on 200mm PCD
240 / 9½
231 / 9⅓
1.1 / 2⅓
Up to 12 years

0 to 100%, MIL-STD-810F
22kg per square inch
Up to 160kph
MIL-STD-202G, Test Condition G, Method 213B
MIL-STD202G, Test Condition B, Method 204

EN61000-6-3:1997, EN61000-6-1:1997
ISO9001:2008
IP68

US Pat. No. 6,667,582, AU Pat. No. 778,918

AVLITE® is a registered trademark of Avlite Systems

3 year warranty
• Radio Controlled - FCC compliant
• Avlite Pilot Activated Lighting Control
• IR LEDs
• External ON/OFF Switch
• External Battery Charging Port
• Manual Operation

• Specifications subject to change or variation without notice
* Subject to standard terms and conditions
† Intensity setting subject to solar availability

SPECIFICATIONS * *

AV-70-HI

Light Characteristics

Light Source

Available colors

Peak Intensity (cd)†

Horizontal Output (degrees)

Vertical Divergence (degrees)

Reflector Type

Available Flash Characteristics

Intensity Adjustments

LED Life Expectancy (hours)

Electrical Characteristics

Operating Voltage (V)

Temperature Range

Solar Characteristics

Solar Module Type

Output (watts)

Solar Module Efficiency (%)

Charging Regulation

Power Supply

Battery Type

Battery Capacity (Ah)

Nominal Voltage (V)

Autonomy (nights)

Radio Controlled (optional)

Frequency

Range

Expandability

Compliance

Physical Characteristics

Body Material

Lens Material

Lens Diameter (mm/inches)

Lens Design

Mounting

Height (mm/inches)

Width (mm/inches)

Mass (kg/lbs)

Product Life Expectancy

Environmental Factors

Humidity

Icing

Wind Speed

Shock

Vibration

Certifications

CE

Quality Assurance

Waterproof

Intellectual Property

Patents

Trademarks

Warranty *

Options Available

12 ultra-high intensity LEDs

Red, Green, White, Yellow, Amber, Blue, Sectored Combinations

Steady-on: Blue - 4.5 Red - 12.1 Green - 16.9 White - 14.2 Yellow - 11.6
Flashing: Not available

360

0 to +7

Omnidirectional 360° LED Reflector (US Pat. No. 6,667,582. AU Pat. No. 778,918)

Not available

Adjustable in 25% increments

>100,000

3.6

-40 to 80°C

Multicrystalline

2.5 (2 x 1.25watt)

14

Microprocessor controlled

High grade NiMH – Environmentally friendly

16

3.6

Steady-on: >19

Flashing: Not available

2.4GHz ISM Band

Up to 1.4km relayed

AvMesh®

FCC / CE

LEXAN® Polycarbonate – UV stabilized

LEXAN® Polycarbonate – UV stabilized

140 / 5½

External optics with interior flute design

6 x 17mm holes on 200mm PCD

240 / 9½

231 / 9⅞

1.41 / 3⅞

Up to 12 years

0 to 100%, MIL-STD-810F

22kg per square inch

Up to 160kph

MIL-STD-202G, Test Condition G, Method 213B

MIL-STD202G, Test Condition B, Method 204

EN61000-6-3:1997. EN61000-6-1:1997

ISO9001:2008

IP68

US Pat. No. 6,667,582. AU Pat. No. 778,918

AVLITE® is a registered trademark of Avlite Systems

3 year warranty

- Radio Controlled – FCC compliant
- Avlite Pilot Activated Lighting Control
- IR LEDs
- External ON/OFF Switch
- External Battery Charging Port
- Manual Operation

• Specifications subject to change or variation without notice
* Subject to standard terms and conditions
† Intensity setting subject to solar availability



Installation

Charging the Battery

New lights should be left in the sun for 1-2 days to ensure battery is charged before placing in service. Please note, light will re-charge even when toggle switch is turned to 'OFF' position.

Preferred Installation Location

For best light performance, ensure solar modules are not covered and are in clear view of the sky with no shadows.

Light Operation

Light is activated by ON/OFF Switch. Intensity and flash settings need to be set prior to installation.

1. Remove the marked flash adjustment bung from the base of the light and set internal toggle switch to 'ON'.
2. The power and range settings of the light are adjusted by setting the DIP switches inside the light. Your light is normally set to maximum range (see 'Selecting an Intensity/Power Setting' section of this manual).
3. Set rotary switches to the required flash code (see 'Selecting a Flash Code' section of this manual).
4. Replace flash adjustment bung.
5. A sealed vent on the base allows air transfer without moisture intake, and should not be disturbed.
6. To test place dark cover (towel or jacket) on top of light to activate sensor, light will come on within one minute.
7. Ensure that the unit is bolted to an even, flat surface.

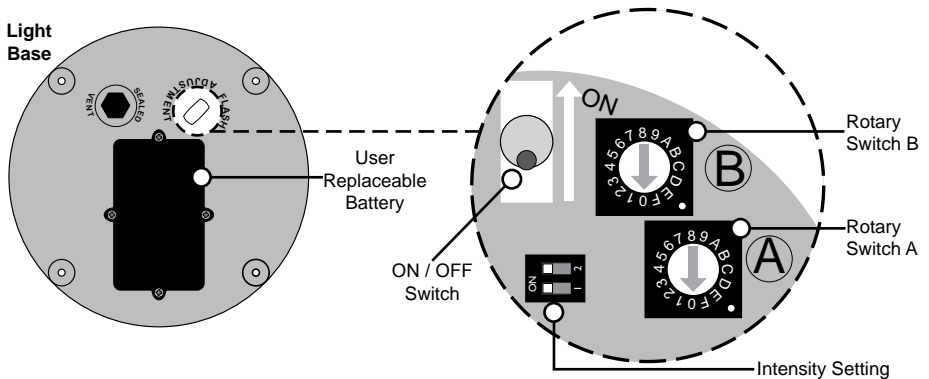

Selecting an Intensity/Power Setting

Intensity/power settings on Avlite lanterns operate via DIP switches, located near the rotary switches on the flasher unit. The intensity/power settings may be used to reduce the power consumption and intensity of the lantern. Setting the lantern to 25% intensity will reduce the power consumption to 25% of the normal 100% setting and the range by 25%. This setting may be used to adjust the current draw of the light to local sunlight conditions.

The following diagrams indicate intensity/power settings:-

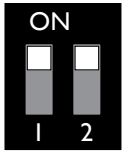

100%

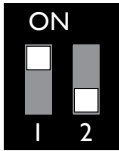

75%

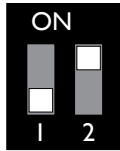

50%

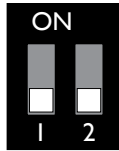

25%

Intensity Setting	Power: mA / hour	
	AV-70	AV-70-HI
100%	34-36	54-56
75%	26-27	40-42
50%	17-18	27-28
25%	8-9	13-14

Power Consumption Calculator

Night Hours (use 13.7 if unknown)		Power mA/hour		Duty Cycle (e.g. 20% = 0.2)		Total power used per night (mA)
	X		X		=	
Total power used per night (mAh)	/	Solar Panel Charge (mA) 279	=	Number of full sunlight hours required to break even (the amount of time it will take for the solar to replace what the light took out overnight)		

If the number of Full Sunlight hours is less than 2.5-3.0 hours, please consider reducing the intensity (Power) or reducing the Duty Cycle.

Selecting a Flash Code - Rotary Switches A & B

All lights have 2 rotary switches marked A and B on the flasher unit. Turning the small arrows to the appropriate number or letter will set the code (see 'Flash Codes' section, of this manual). The unit may take up to one minute to activate a new flash code. A comprehensive list of available flash codes is listed on pages in the 'Flash Codes' section of this manual.

Example:

SWITCH		FLASH CODE	ON	OFF
A	B			
A	0	FL 3 S	0.3	2.7

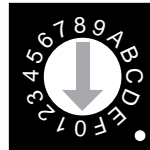



Flash Codes

AVLITE® code reference is listed by number of flashes

**For the latest version of this document visit www.avlite.com,
or email support@avlite.com**

Symbols

FL	Flash followed by number Eg. FL 1 S, one flash every second
F	Fixed
Q	Quick flash
VQ	Very quick flash
OC	Occulting; greater period on than off
ISO	Isophase; equal period on and off
LFL	Long flash long
MO	Morse code () contains letter

For example, VQ (6) + LFL 10 S means 6 very quick flashes followed by a long flash, during a 10-second interval.

The amount of power your light draws through the night depends on the duty cycle, i.e. the amount of time on as a proportion to the timing cycle. For example, 0.5 seconds on and 4.5 seconds off equals a 10% duty cycle.

It is best to operate at the lowest duty cycle appropriate to the actual needs of the application.

Please note, Avlite models will retain full autonomy in normal operating conditions with duty-cycles up to approximately 30%. In applications whereby duty cycles exceed this limit, a reduction in light intensity is recommended. Please contact a Avlite consultant if assistance is required.

SWITCH	FLASH CODE	ON	OFF
A	B		
0	0 F (Steady light)		
D	3 VQ 0.5 S	0.2	0.3
E	3 VQ 0.6 S	0.2	0.4
F	3 VQ 0.6 S	0.3	0.3
7	3 Q 1 S	0.2	0.8
8	3 Q 1 S	0.3	0.7
9	3 Q 1 S	0.4	0.6
A	3 Q 1 S	0.5	0.5
8	4 Q 1 S	0.8	0.2
B	3 Q 1.2 S	0.3	0.9
9	4 Q 1.2 S	0.5	0.7
C	3 Q 1.2 S	0.6	0.6
F	4 FL 1.5 S	0.2	1.3
1	0 FL 1.5 S	0.3	1.2
0	5 FL 1.5 S	0.4	1.1
0	4 FL 1.5 S	0.5	1.0
2	0 FL 2 S	0.2	1.8
3	0 FL 2 S	0.3	1.7
4	0 FL 2 S	0.4	1.6
5	0 FL 2 S	0.5	1.5
6	0 FL 2 S	0.7	1.3
7	0 FL 2 S	0.8	1.2
1	2 ISO 2 S	1.0	1.0
8	0 FL 2.5 S	0.3	2.2
9	0 FL 2.5 S	0.5	2.0
D	6 FL 2.5 S	1.0	1.5
1	5 FL 3 S	0.2	2.8
A	0 FL 3 S	0.3	2.7
2	5 FL 3 S	0.4	2.6
B	0 FL 3 S	0.5	2.5
3	5 FL 3 S	0.6	2.4
C	0 FL 3 S	0.7	2.3
D	0 FL 3 S	1.0	2.0
2	2 ISO 3 S	1.5	1.5
5	4 OC 3 S	2.0	1.0
E	2 OC 3 S	2.5	0.5
4	6 OC 3.5 S	2.5	1.0
4	5 FL 4 S	0.2	3.8
5	5 FL 4 S	0.3	3.7
E	0 FL 4 S	0.4	3.6
F	0 FL 4 S	0.5	3.5
6	5 FL 4 S	0.6	3.4
0	1 FL 4 S	0.8	3.2
1	1 FL 4 S	1.0	3.0
2	1 FL 4 S	1.5	2.5
3	2 ISO 4 S	2.0	2.0
3	6 OC 4 S	2.5	1.5
F	2 OC 4 S	3.0	1.0
3	1 FL 4.3 S	1.3	3.0
8	5 FL 5 S	0.2	4.8
4	1 FL 5 S	0.3	4.7
5	1 FL 5 S	0.5	4.5
9	5 FL 5 S	0.9	4.1
6	1 FL 5 S	1.0	4.0

SWITCH	FLASH CODE	ON	OFF
A	B		
7	1 FL 5 S	1.5	3.5
4	2 ISO 5 S	2.5	2.5
8	2 LFL 5 S	2.0	3.0
0	3 OC 5 S	3.0	2.0
1	3 OC 5 S	4.0	1.0
2	3 OC 5 S	4.5	0.5
C	6 FL 6 S	0.2	5.8
B	5 FL 6 S	0.3	5.7
C	5 FL 6 S	0.4	5.6
8	1 FL 6 S	0.5	5.5
9	1 FL 6 S	0.6	5.4
A	1 FL 6 S	1.0	5.0
7	5 FL 6 S	1.2	4.8
B	1 FL 6 S	1.5	4.5
5	2 ISO 6 S	3.0	3.0
9	2 LFL 6 S	2.0	4.0
6	4 OC 6 S	4.0	2.0
3	3 OC 6 S	4.5	1.5
4	3 OC 6 S	5.0	1.0
A	4 FL 7 S	1.0	6.0
9	6 FL 7 S	2.0	5.0
5	6 OC 7 S	4.5	2.5
D	5 FL 7.5 S	0.5	7.0
C	1 FL 7.5 S	0.8	6.7
E	5 FL 8 S	0.5	7.5
B	4 FL 8 S	1.0	7.0
6	2 ISO 8 S	4.0	4.0
A	2 LFL 8 S	2.0	6.0
6	6 OC 8 S	5.0	3.0
B	2 LFL 8 S	3.0	5.0
F	5 FL 9 S	0.9	8.1
C	4 FL 9 S	1.0	8.0
7	6 OC 9 S	6.0	3.0
0	6 FL 10 S	0.2	9.8
1	6 FL 10 S	0.3	9.7
D	1 FL 10 S	0.5	9.5
2	6 FL 10 S	0.8	9.2
E	1 FL 10 S	1.0	9.0
1	4 FL 10 S	1.5	8.5
C	2 LFL 10 S	2.0	8.0
D	2 LFL 10 S	3.0	7.0
7	2 ISO 10 S	5.0	5.0
2	4 LFL 10 S	4.0	6.0
8	6 OC 10 S	6.0	4.0
5	3 OC 10 S	7.0	3.0
6	3 OC 10 S	7.5	2.5
F	1 FL 12 S	1.2	10.8
D	4 FL 12 S	2.5	9.5
3	4 LFL 12 S	2.0	10.0
0	2 FL 15 S	1.0	14.0
4	4 LFL 15 S	4.0	11.0
7	4 OC 15 S	10	5.0
A	6 LFL 20 S	2.0	18.0
E	4 FL 26 S	1.0	25.0

SWITCH	FLASH CODE	ON	OFF	ON	OFF
A	B				
0	A FL (2) 4 S	0.5	1.0	0.5	2.0
E	B VQ (2) 4 S	0.2	1.0	0.2	2.6
1	A FL (2) 4.5 S	0.3	1.0	0.3	2.9
2	A FL (2) 4.5 S	0.4	1.0	0.4	2.7
3	A FL (2) 4.5 S	0.5	1.0	0.5	2.5
F	9 FL (2) 5 S	0.2	0.8	0.2	3.8
2	C FL (2) 5 S	0.2	1.2	0.2	3.4
4	A FL (2) 5 S	0.4	0.6	0.4	3.6
0	7 FL (2) 5 S	0.5	1.0	0.5	3.0
1	7 FL (2) 5 S	1.0	1.0	1.0	2.0
9	B Q (2) 5 S	0.3	0.7	0.3	3.7
2	9 Q (2) 5 S	0.5	0.5	0.5	3.5
5	A FL (2) 5.5 S	0.4	1.4	0.4	3.3
7	8 FL (2) 6 S	0.3	0.6	1.0	4.1
A	A FL (2) 6 S	0.3	0.9	0.3	4.5
6	A FL (2) 6 S	0.3	1.0	0.3	4.4
7	A FL (2) 6 S	0.4	1.0	0.4	4.2
9	9 FL (2) 6 S	0.5	1.0	0.5	4.0
2	8 FL (2) 6 S	0.8	1.2	0.8	3.2
3	7 FL (2) 6 S	1.0	1.0	1.0	3.0
3	9 Q (2) 6 S	0.3	0.7	0.3	4.7
A	9 FL (2) 7 S	1.0	1.0	1.0	4.0
7	B FL (2) 8 S	0.4	0.6	2.0	5.0
8	A FL (2) 8 S	0.4	1.0	0.4	6.2
4	7 FL (2) 8 S	0.5	1.0	0.5	6.0
8	8 FL (2) 8 S	0.8	1.2	2.4	3.6
5	7 FL (2) 8 S	1.0	1.0	1.0	5.0
4	C OC (2) 8 S	3.0	2.0	1.0	2.0
5	C OC (2) 8 S	5.0	1.0	1.0	1.0
F	B VQ (2) 8 S	0.2	1.0	0.2	6.6
9	A FL (2) 10 S	0.4	1.6	0.4	7.6
6	7 FL (2) 10 S	0.5	1.0	0.5	8.0
7	7 FL (2) 10 S	0.5	1.5	0.5	7.5
6	9 FL (2) 10 S	0.5	2.0	0.5	7.0
8	7 FL (2) 10 S	0.8	1.2	0.8	7.2
B	9 FL (2) 10 S	1.0	1.0	1.0	7.0
9	7 FL (2) 10 S	1.0	1.5	1.0	6.5
4	9 Q (2) 10 S	0.6	0.4	0.6	8.4
B	A FL (2) 12 S	0.4	1.0	0.4	10.2
C	9 FL (2) 12 S	0.5	1.0	0.5	10.0
D	9 FL (2) 12 S	1.5	2.0	1.5	7.0
A	8 FL (2) 15 S	0.5	1.5	2.0	11.0
A	7 FL (2) 15 S	1.0	2.0	1.0	11.0
8	B Q (2) 15 S	0.2	0.8	0.2	13.8
C	A FL (2) 20 S	1.0	3.0	1.0	15.0
D	A FL (2) 25 S	1.0	1.0	1.0	22.0

SWITCH	FLASH CODE	ON	OFF	ON	OFF	ON	OFF
A	B						
7	9 Q (3) 5 S	0.5	0.5	0.5	0.5	0.5	2.5
5	9 VQ (3) 5 S	0.2	0.3	0.2	0.3	0.2	3.8
0	C VQ (3) 5 S	0.3	0.2	0.3	0.2	0.3	3.7
E	9 VQ (3) 5 S	0.3	0.3	0.3	0.3	0.3	3.5
3	C FL (3) 6 S	0.5	1.0	0.5	1.0	0.5	2.5
2	B FL (2+1) 6 S	0.3	0.4	0.3	1.2	0.3	3.5

SWITCH	FLASH CODE	ON	OFF	ON	OFF	ON	OFF	
A	B							
A	B	Q (3) 6 S	0.3	0.7	0.3	0.7	0.3	3.7
F	A	FL (3) 8 S	0.5	1.0	0.5	1.0	0.5	4.5
0	B	FL (3) 9 S	0.3	1.0	0.3	1.0	0.3	6.1
B	7	FL (3) 9 S	0.8	1.2	0.8	1.2	0.8	4.2
B	8	FL (3) 10 S	0.3	0.7	0.3	0.7	0.9	7.1
C	8	FL (3) 10 S	0.4	0.6	0.4	0.6	1.2	6.8
C	B	FL (3) 10 S	0.5	0.5	0.5	0.5	0.5	7.5
C	7	FL (3) 10 S	0.5	1.5	0.5	1.5	0.5	5.5
D	B	FL (3) 10 S	0.6	0.6	0.6	0.6	0.6	7.0
D	7	FL (3) 10 S	1.0	1.0	1.0	1.0	1.0	5.0
3	8	FL (2+1) 10 S	0.5	0.7	0.5	2.1	0.5	5.7
8	9	OC (3) 10 S	5.0	1.0	1.0	1.0	1.0	1.0
B	B	Q (3) 10 S	0.3	0.7	0.3	0.7	0.3	7.7
D	8	FL (2 + 1) 10 S	0.5	0.5	0.5	0.5	1.5	6.5
1	B	FL (3) 12 S	0.5	1.5	0.5	1.5	0.5	7.5
E	A	FL (3) 12 S	0.5	2.0	0.5	2.0	0.5	6.5
E	7	FL (3) 12 S	0.8	1.2	0.8	1.2	0.8	7.2
B	6	FL (3) 12 S	1.0	1.0	1.0	3.0	1.0	5.0
4	8	FL (2+1) 12 S	0.8	1.2	0.8	2.4	0.8	6.0
5	8	FL (2+1) 12 S	1.0	1.0	1.0	4.0	1.0	4.0
1	8	FL (2+1) 13.5 S	1.0	1.0	1.0	4.0	1.0	5.5
F	7	FL (3) 15 S	0.3	1.7	0.3	1.7	0.3	10.7
9	D	FL (3) 15 S	0.4	1.0	0.4	1.0	0.4	11.8
0	8	FL (3) 15 S	0.5	1.5	0.5	1.5	0.5	10.5
F	8	FL (2+1) 15 S	0.6	0.3	0.6	0.3	1.4	11.8
0	9	FL (2+1) 15 S	0.7	0.5	0.7	0.5	1.9	10.7
1	9	FL (2+1) 15 S	0.7	0.7	0.7	0.7	2.1	10.1
6	8	FL (2+1) 15 S	1.0	2.0	1.0	5.0	1.0	5.0
1	C	VQ (3) 15 S	0.1	0.5	0.1	0.5	0.1	13.7
4	B	FL (3) 20 S	0.5	3.0	0.5	3.0	0.5	12.5
3	B	FL (3) 20 S	0.5	1.5	0.5	1.5	0.5	15.5
5	B	FL (3) 20 S	0.8	1.2	0.8	1.2	0.8	15.2
6	B	FL (3) 20 S	1.0	1.0	1.0	1.0	1.0	15.0

SWITCH	FLASH CODE	ON	OFF	ON	OFF	ON	OFF	ON	OFF
A	B								
B	F	VQ (4) 4 S	0.3	0.3	0.3	0.3	0.3	0.3	2.3
B	D	Q (4) 6 S	0.3	0.7	0.3	0.7	0.3	0.7	2.7
8	D	Q (4) 6 S	0.4	0.6	0.4	0.6	0.4	0.6	2.6
1	D	FL (4) 10 S	0.5	1.0	0.5	1.0	0.5	1.0	5.0
2	D	FL (4) 10 S	0.8	1.2	0.8	1.2	0.8	1.2	3.2
F	E	Q (4) 10 S	0.3	0.7	0.3	0.7	0.3	0.7	6.7
B	E	FL (4) 12 S	0.3	1.7	0.3	1.7	0.3	1.7	5.7
4	F	FL (4) 12 S	0.5	0.5	0.5	0.5	0.5	0.5	8.5
C	E	FL (4) 12 S	0.5	1.5	0.5	1.5	0.5	1.5	5.5
3	D	FL (4) 12 S	0.8	1.2	0.8	1.2	0.8	1.2	5.2
A	D	Q (4) 12 S	0.3	0.7	0.3	0.7	0.3	0.7	8.7
4	D	FL (4) 15 S	0.5	1.5	0.5	1.5	0.5	1.5	8.5
8	E	FL (4) 15 S	1.0	1.0	1.0	1.0	1.0	1.0	8.0
7	D	FL (4) 15 S	1.5	0.5	0.5	0.5	0.5	0.5	10.5
D	E	FL (4) 16 S	0.5	1.5	0.5	1.5	0.5	1.5	9.5
C	D	FL (4) 20 S	0.3	3.0	0.3	3.0	0.3	3.0	9.8
5	D	FL (4) 20 S	0.5	1.5	0.5	1.5	0.5	1.5	13.5
0	D	FL (4) 20 S	0.5	1.5	0.5	1.5	0.5	4.5	10.5
3	F	FL (4) 20 S	1.5	1.5	1.5	1.5	1.5	1.5	9.5
0	F	Q (4) 20 S	0.5	0.5	0.5	0.5	0.5	0.5	16.5
E	E	Q (4) 28 S	0.5	0.5	0.5	0.5	0.5	0.5	24.5
6	F	FL (4) 30 S	0.5	0.5	0.5	0.5	0.5	0.5	26.5

SWITCH	FLASH CODE	ON	OFF	ON	OFF	ON	OFF	ON	OFF	ON	OFF	
A	B											
D	D	Q (5) 7 S	0.3	0.7	0.3	0.7	0.3	0.7	0.3	0.7	0.3	2.7
E	D	Q (5) 10 S	0.3	0.7	0.3	0.7	0.3	0.7	0.3	0.7	0.3	5.7
E	8	FL (5) 12 S	0.5	1.5	0.5	1.5	0.5	1.5	0.5	1.5	0.5	3.5
5	F	FL (5) 20 S	0.5	0.5	0.5	0.5	0.5	0.5	0.5	0.5	0.5	15.5
9	F	FL (5) 20 S	0.8	1.2	0.8	1.2	0.8	1.2	0.8	1.2	0.8	11.2
9	E	FL (5) 20 S	1.0	1.0	1.0	1.0	1.0	1.0	1.0	1.0	1.0	11.0

SWITCH	FLASH CODE	ON	OFF	ON	OFF	ON	OFF	ON	OFF	ON	OFF	ON	OFF
A	B												
F	D	Q (6) 10 S	0.3	0.7	0.3	0.7	0.3	0.7	0.3	0.7	0.3	0.7	4.7
A	F	FL (6) 15 S	0.3	0.7	0.3	0.7	0.3	0.7	0.3	0.7	0.3	0.7	9.7
7	F	FL (6) 15 S	0.5	1.0	0.5	1.0	0.5	1.0	0.5	1.0	0.5	1.0	7.0

SWITCH	FLASH CODE	ON	OFF	ON	OFF	ON	OFF	ON	OFF	ON	OFF	ON	OFF	ON	OFF	
A	B															
6	E	VQ (6) + LFL 10 S	0.2	0.3	0.2	0.3	0.2	0.3	0.2	0.3	0.2	0.3	0.2	0.3	2.0	5.0
7	E	VQ (6) + LFL 10 S	0.3	0.3	0.3	0.3	0.3	0.3	0.3	0.3	0.3	0.3	0.3	0.3	2.0	4.4
2	F	Q (6) + LFL 15 S	0.2	0.8	0.2	0.8	0.2	0.8	0.2	0.8	0.2	0.8	0.2	0.8	2.0	7.0
2	E	Q (6) + LFL 15 S	0.3	0.7	0.3	0.7	0.3	0.7	0.3	0.7	0.3	0.7	0.3	0.7	2.0	7.0
3	E	Q (6) + LFL 15 S	0.6	0.6	0.6	0.6	0.6	0.6	0.6	0.6	0.6	0.6	0.6	0.6	2.0	5.8
8	F	VQ (6) + LFL 15 S	0.3	0.3	0.3	0.3	0.3	0.3	0.3	0.3	0.3	0.3	0.3	0.3	2.0	9.4

SWITCH	FLASH CODE	ON	OFF	ON	OFF	ON	OFF	ON	OFF	ON	OFF	ON	OFF	ON	OFF	ON	OFF	
A	B																	
4	E	VQ (9) 10 S	0.2	0.3	0.2	0.3	0.2	0.3	0.2	0.3	0.2	0.3	0.2	0.3	0.2	0.3	0.2	5.8
5	E	VQ (9) 10 S	0.3	0.3	0.3	0.3	0.3	0.3	0.3	0.3	0.3	0.3	0.3	0.3	0.3	0.3	0.3	4.9
1	F	Q (9) 15 S	0.2	0.8	0.2	0.8	0.2	0.8	0.2	0.8	0.2	0.8	0.2	0.8	0.2	0.8	0.2	6.8
0	E	Q (9) 15 S	0.3	0.7	0.3	0.7	0.3	0.7	0.3	0.7	0.3	0.7	0.3	0.7	0.3	0.7	0.3	6.7
1	E	Q (9) 15 S	0.6	0.6	0.6	0.6	0.6	0.6	0.6	0.6	0.6	0.6	0.6	0.6	0.6	0.6	0.6	4.8

SWITCH	FLASH CODE	ON	OFF	ON	OFF	ON	OFF	ON	OFF
A	B								
MORSE CODE () INDICATES LETTER									
7	8	MO (A) 6 S	0.3	0.6	1.0	4.1			
7	B	MO (A) 8 S	0.4	0.6	2.0	5.0			
8	8	MO (A) 8 S	0.8	1.2	2.4	3.6			
B	8	MO (U) 10 S	0.3	0.7	0.3	0.7	0.9	7.1	
C	8	MO (U) 10 S	0.4	0.6	0.4	0.6	1.2	6.8	
D	8	MO (U) 10 S	0.5	0.5	0.5	0.5	1.5	6.5	
9	8	MO (A) 10 S	0.5	0.5	1.5	7.5			
8	9	MO (D) 10 S	5.0	1.0	1.0	1.0	1.0	1.0	
A	8	MO (A) 15 S	0.5	1.5	2.0	11.0			
F	8	MO (U) 15 S	0.6	0.3	0.6	0.3	1.4	11.8	
0	9	MO (U) 15 S	0.7	0.5	0.7	0.5	1.9	10.7	
1	9	MO (U) 15 S	0.7	0.7	0.7	0.7	2.1	10.1	
7	D	MO (B) 15 S	1.5	0.5	0.5	0.5	0.5	0.5	10.5



Installing the Light Assembly: Mounting Options

Installing the Light Assembly to the Rubber Tile

The completed AV-70 rubber tile assembly is to be mounted on a surface capable of supporting 6kg minimum. Securing the rubber tile to the mounting surface is optional, however, Avlite recommend that the tile be secured at a minimum of two points.

- a. Insert bolts through the three-centremost holes in the tile, entering from the bottom face (within the triangular recess). It may be necessary to use a rubber mallet to insert the bolts.
- b. Fit the AV-70 light over the bolts on the top face of the tile. (It is possible to align the lens ridge with the sides of the tile, but this is not a requirement).
- c. Install a penny washer and a Nylock nut on each bolt and tighten.
- d. Place the completed light assembly in the desired location.
- e. During Installation every effort should be made to ensure that the light is level when installation is complete. When installing the tile ensure that it is level using a spirit level.
- f. Using a hammer, drive steel pegs through the holes in the corners of the rubber tile being careful not to damage the AV-70 light.

Note: *Other means of securing the tile may be used where the mounting surface is not suited to the use of steel pegs.*

Figure 2 Rubber Tile Installation

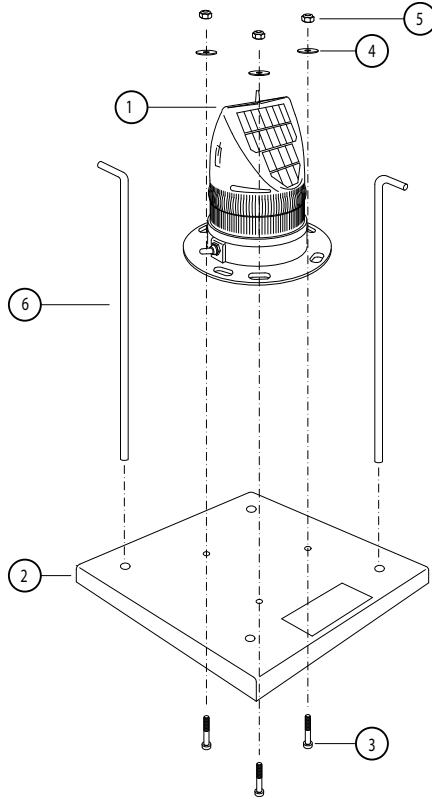

Item	Description	Qty
1	AV-70 Solar Airfiled Light	1
2	Rubber Tile	1
3	Bolt, 8mm x 50	3
4	Penny Washer, 8mm	3
5	Nylock Nut, 8mm	3
6	Steel Peg, Ø12mm	Optional (2)

Installing the Light Assembly to the Frangible Stake Mount

The completed AV-70 mount plate assembly is to be mounted on the Stake (Fig 3) in firm soil (not loose sand, screenings or other unbound material).

- a. Fit the AV-70 light on the top of the mounting plate. Insert bolts through the four holes in the mount, entering from the bottom. Install a penny washer and a Nylock nut on each bolt and tighten.
- b. Fit the boss of the mount plate into the shorter barrel of the frangible sleeve. Using a 6mm Allen key, tighten the socket head cap screw against the stake mount boss.
- c. Use a sledge hammer to drive the stake into the soil at the chosen location. Drive the stake down until the bottom of the stake sleeve is at ground level.
During Installation every effort should be made to ensure that the light is level when installation is complete. When installing a stake mount into the ground ensure that the stake is installed straight into the ground and not on an angle. Ensure that the mounting plate is level using a spirit level.
- d. Fit the AV-70 mount plate assembly on top of the stake. The longer barrel of the Frangible Sleeve should completely cover the stake sleeve. Using a 6mm Allen key, tighten the bottom socket head cap screw against the stake sleeve.

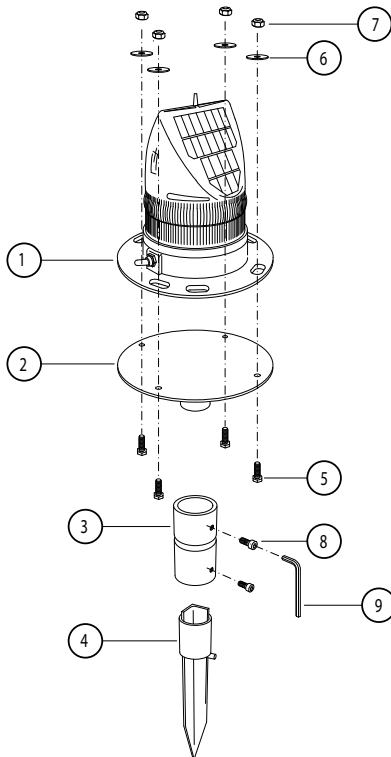

Item	Description	Qty
1	AV-70 Solar Airfiled Light	1
2	Mount Plate	1
3	Frangible Sleeve	1
4	Stake (355mm)	1
5	Bolt, 8mm x 30	4
6	Penny Washer, 8mm	4
7	Nylock Nut, 8mm	4
8	Socket Head Cap Screw, 8mm x 16	2
9	Allen Key, 6mm	1

Figure 3 Frangible Stake Mount Installation

Installing the Light Assembly to the Frangible Concrete Mount

- a. Mount the base plate to the concrete using 4 x M8 concrete bolts.
- b. Fit the frangible mounting plate onto the concrete base plate and secure using the M8 x 16 SHCS
- c. During Installation every effort should be made to ensure that the light is level when installation is complete.

The following guide lines will help to ensure that the lights will be installed correctly.

- When installing a concrete mount plate ensure that the concrete pad is level using a spirit level.

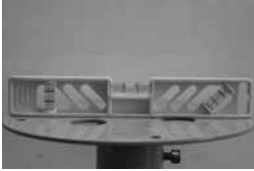

Check the mounting plate with a spirit level in all directions

- Fit the frangible coupling and top mounting plate and using a spirit level check that the light mounting plate is level using a spirit level.
- d. Fit the AV-70 to the light mounting plate using M8 SHCS, large flat washers and Nylock nuts.

Note: After adjustments, ensure all nuts and bolts are tightened securely and all tools, spares and packaging are removed from the runway.

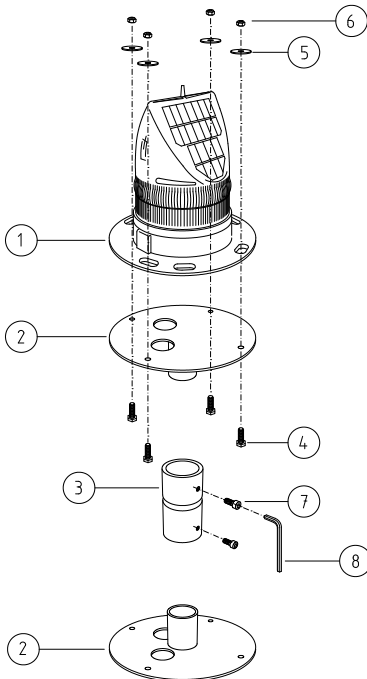

Item	Description	Qty
1	AV-70 Solar Airfiled Light	1
2	Mount Plate	2
3	Frangible Sleeve	1
4	Bolt, 8mm x 25	4
5	Penny Washer, 8mm	4
6	Nylock Nut, 8mm	4
7	Socket Head Cap Screw, 8mm x 16	2
8	Allen Key, 6mm	1

Figure 4 Frangible Concrete Mount Installation



Maintenance and Servicing

Designed to be maintenance free, the AV-70 / AV-70-HI requires minimal attention, though the following maintenance and servicing information is provided to help ensure the life of your Avlite product.

1. Cleaning Solar Panels - occasional cleaning of the solar panels may be required. Using a cloth and warm soapy water, wipe off any foreign matter before rinsing the panels with fresh water.
2. Battery Check - inspection of batteries should be performed every three years (minimum) to ensure that the charger, battery and ancillary electronics are functioning correctly. Using a voltage meter, check that the battery voltage is at least 3.6 volts under 100mA load, and ensure all terminals are clear of foreign matter.

Replacing the battery- Don't throw the unit out!!

The AV-70 / AV-70-HI lights are the only compact aviation light with a double sealed battery compartment. This provides the user with the ability to change the battery after years of operation.

1. Remove the marked flash adjustment bung from the base of the light and set internal toggle switch to 'OFF'.
2. Unscrew small screws to remove battery plate.
3. Remove battery from AV-70 / AV-70-HI case and unscrew positive and negative leads.
4. Discard old battery in a safe manner.
5. Reattach positive and negative leads to new battery and then place back into case.
6. Reattach battery plate and switch light 'ON' via internal switch. Close the bung.
7. To test place dark cover (towel or jacket) on top of light to activate sensor, light will come on.

Care must be taken to observe the polarity of the battery before the leads are re-connected, and ensure the replacement battery is correctly fitted. Always discard old batteries in a safe manner.

Long Term Storage Instructions

If the AV-70 / AV-70-HI is to be placed in storage for an extended period, being more than 5 months, please follow the below steps.

1. The 3.6V NiMH Battery must be stored in a fully charged condition.
2. Remove the Flash Adjustment plug and turn the ON/OFF switch to the OFF position.
3. Remove the battery cover and disconnect the Positive (+) Terminal.
4. Fold the Terminal away from the Negative Battery Terminal.
5. Replace the Battery Cover
6. Replace the Flash Adjustment Plug.

All batteries will discharge over time and the rate of discharge is dependent on temperature. If the light is being stored in temperatures greater than 40°C the battery will discharge faster.

Please check battery every 3-6 months and recharge if necessary.

Recharging the Battery

1. Remove the Battery Cover and connect the Positive Terminal.
2. Remove the Flash Adjustment Plug and turn the ON/OFF switch to the ON position.
3. Reconnect the Light Head and place unit in the sun for 2-4 days

Or

Reconnect Light Head and place in front of a halogen lamp for 2-3 days. (Do not place the halogen light too close to the solar panel or the panel may be overheated)

Check the battery voltage regularly to make sure the unit is charging correctly.

After the battery has been recharged, switch the light OFF.

Trouble Shooting

Problem	Remedy
Light will not activate.	<ul style="list-style-type: none"> • Ensure internal toggle switch is set to the 'ON position. • Ensure light is in darkness. • Wait at least 60 seconds for the program to initialise in darkness. • Ensure switch setting is on a valid code (See '<i>Flash Codes</i>' section of this manual). • Ensure battery terminals are properly connected. • Ensure battery voltage is above 3.6volts.
Timing codes will not change.	<ul style="list-style-type: none"> • Turn rotary switches several times to ensure contacts are clear.
Light will not operate for the entire night.	<ul style="list-style-type: none"> • Expose light to direct sunlight and monitor operation for several days. Avlite products typically require 1.5 hours of direct sunlight per day to retain full autonomy. From a discharged state, the light may require several days of operational conditions to 'cycle' up to full autonomy. • Reducing the light output intensity or duty cycle (flash code) will reduce current draw on the battery. • Ensure solar module is clean and not covered by shading during the day.
Lights are constantly on during the day.	<ul style="list-style-type: none"> • Ensure the flash code is not set to F F. This flash code is for testing purposes only and will be steady on for 24 hours a day.

Radio controlled models of the AV-70 / AV-70-HI are fitted with a red Status LED. This is found near the Flash Code Switches. It helps determine a fault with the unit depending on the flash rate of the Status LED.

Flash Rate		Mode	Status	Condition
On (sec.)	OFF			
Steady Off		Off	Normal	Normal running condition in daylight.
1/10	1	On	Normal	Lantern is not synchronised to other lanterns.
1	1	On	Normal	Lantern is synchronised to surrounding lanterns.
Steady On		Off	Flat Battery	Battery is flat.
1/10	1/10	On	Low Battery	Battery is low.
1	2/10	On	Factory Set.	Unit is in factory setup mode (FF). Change flash code.



Notes



Avlite Light Warranty V1.1

Activating the Warranty

Upon purchase, the Avlite Systems warranty must be activated for recognition of future claims. To do this you have two (2) options:

1. **Postal Registration**

Please complete the Avlite Systems Warranty Registration Card and return to Avlite within 30 days of your purchase.

2. **Online Registration**

Please complete the Online Registration Form at; www.avlite.com

Avlite Systems will repair or replace your lantern in the event of electronic failure for a period of up to three years from the date of purchase.

The unit must be returned to Avlite freight prepaid.

Warranty Terms

1. Avlite Systems warrants that any Avlite aviation products fitted with telemetry equipment including but not limited to AIS, GSM, GPS or RF ("Telemetry Products") will be free from defective materials and workmanship under normal and intended use, subject to the conditions hereinafter set forth, for a period of twelve (12) months from the date of purchase by the original purchaser.
2. Avlite Systems warrants that any rotationally-moulded products ("Roto-Moulded Products") and accessory products ("Accessory Products") will be free from defective materials and workmanship under normal and intended use, subject to the conditions hereinafter set forth, for a period of twelve (12) months from the date of purchase by the original purchaser.
3. Avlite Systems warrants that any Avlite aviation products other than the Telemetry Products, Roto-Moulded Products and Accessory Products ("Avlite Products") will be free from defective materials and workmanship under normal and intended use, subject to the conditions hereinafter set forth, for a period of three (3) years from the date of purchase by the original purchaser.
4. Avlite Systems will repair or replace, at Avlite's sole discretion, any Telemetry Products, Roto-Moulded Products, Accessory Products or Avlite Products found to be defective in material and workmanship in the relevant warranty period so long as the Warranty Conditions (set out below) are satisfied.
5. If any Telemetry Products or Avlite Products are fitted with a rechargeable battery, Avlite Systems warrants the battery will be free from defect for a period of one (1) year when used within original manufacturer's specifications and instructions.

Warranty Conditions

This Warranty is subject to the following conditions and limitations;

1. The warranty is applicable to lanterns manufactured from 1/1/2009.
2. The warranty is void and inapplicable if:
 - a. the product has been used or handled other than in accordance with the instructions in the owner's manual and any other information or instructions provided to the customer by Avlite;
 - b. the product has been deliberately abused, or misused, damaged by accident or neglect or in being transported; or
 - c. the defect is due to the product being repaired or tampered with by anyone other than Avlite or authorised Avlite repair personnel.
3. The customer must give Avlite Systems notice of any defect with the product within 30 days of the customer becoming aware of the defect.
4. Rechargeable batteries have a limited number of charge cycles and may eventually need to be replaced. Typical battery replacement period is 3-4 years. Long term exposure to high temperatures will shorten the battery life. Batteries used or stored in a manner inconsistent with the manufacturer's specifications and instructions shall not be covered by this warranty.



5. No modifications to the original specifications determined by Avlite shall be made without written approval of Avlite Systems.
6. Avlite lights can be fitted with 3rd party power supplies and accessories but are covered by the 3rd party warranty terms and conditions.
7. The product must be packed and returned to Avlite Systems by the customer at his or her sole expense. Avlite Systems will pay return freight of its choice. A returned product must be accompanied by a written description of the defect and a photocopy of the original purchase receipt. This receipt must clearly list model and serial number, the date of purchase, the name and address of the purchaser and authorised dealer and the price paid by the purchaser. On receipt of the product, Avlite Systems will assess the product and advise the customer as to whether the claimed defect is covered by this warranty.
8. Avlite Systems reserves the right to modify the design of any product without obligation to purchasers of previously manufactured products and to change the prices or specifications of any product without notice or obligation to any person.
9. Input voltage shall not exceed those recommended for the product.
10. Warranty does not cover damage caused by the incorrect replacement of battery in solar lantern models.
11. This warranty does not cover any damage or defect caused to any product as a result of water flooding or any other acts of nature.
12. There are no representations or warranties of any kind by Avlite or any other person who is an agent, employee, or other representative or affiliate of Avlite, express or implied, with respect to condition of performance of any product, their merchantability, or fitness for a particular purpose, or with respect to any other matter relating to any products.

Limitation of Liability

To the extent permitted by section 68A of the Trade Practices Act 1974 (Cth), the liability of Avlite Systems under this Warranty will be, at the option of Avlite Systems, limited to either the replacement or repair of any defective product covered by this Warranty. Avlite Systems will not be liable to Buyer for consequential damages resulting from any defect or deficiencies in accepted items.

Limited to Original Purchaser

This Warranty is for the sole benefit of the original purchaser of the covered product and shall not extend to any subsequent purchaser of the product.

Miscellaneous

Apart from the specific warranties provided under this warranty, all other express or implied warranties relating to the above product is hereby excluded to the fullest extent allowable under law. The warranty does not extend to any lost profits, loss of good will or any indirect, incidental or consequential costs or damages or losses incurred by the purchaser as a result of any defect with the covered product.

Warrantor

Avlite Systems has authorised distribution in many countries of the world. In each country, the authorised importing distributor has accepted the responsibility for warranty of products sold by distributor. Warranty service should normally be obtained from the importing distributor from whom you purchased your product. In the event of service required beyond the capability of the importer, Avlite Systems will fulfil the conditions of the warranty. Such product must be returned at the owner's expense to the Avlite Systems factory, together with a photocopy of the bill of sale for that product, a detailed description of the problem, and any information necessary for return shipment.

Other Avlite Products Available



Solar Aviation Lighting



**Radio Controlled &
PALC Systems (FCC Compliant)**



**Obstruction Lighting
(LIOL A & LIOL B)**



**Airfield Markers
& Accessories**

Typical Applications

- Temporary & permanent airfield lighting
- Remote, emergency & defence airfield lighting
 - Barricade, hazard & perimeter lighting
 - Helipad lighting
- Obstruction lighting

For a complete list of product compliances including ICAO & FAA, please contact Avlite today

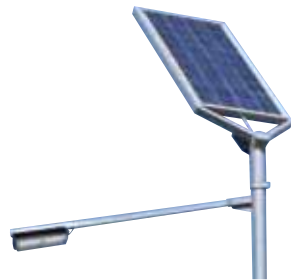

Area & Sign Lighting



Head Office

Avlite Systems
11 Industrial Drive
Somerville, Vic 3912
Australia

Tel: +61 (0)3 5977 6128
Fax: +61 (0)3 5977 6124

Email: info@avlite.com
Internet: www.avlite.com

A subsidiary of Sealite Pty Ltd www.sealite.com