

Avlite[®]
www.avlite.com



AV-60
Solar Aviation Light
Installation & Service Manual

Version 2.0

AV-60

Solar Aviation Light

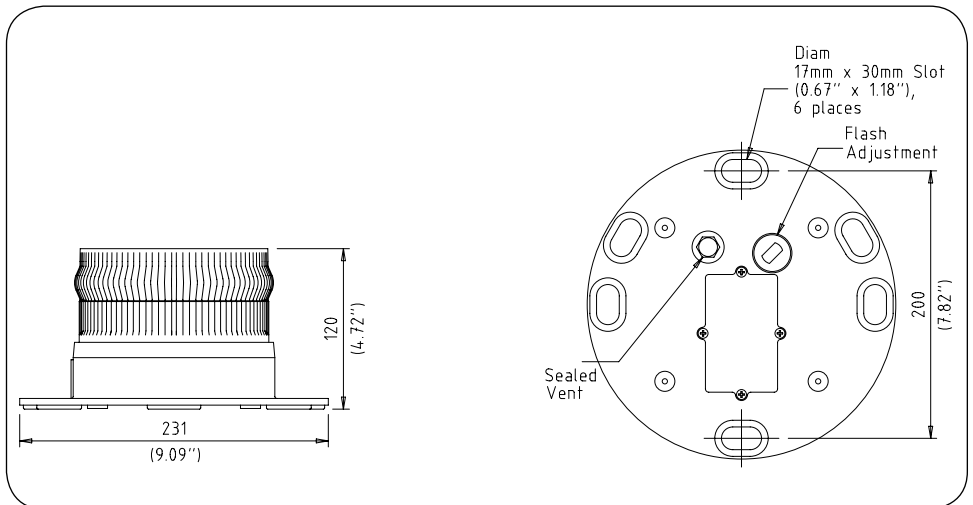
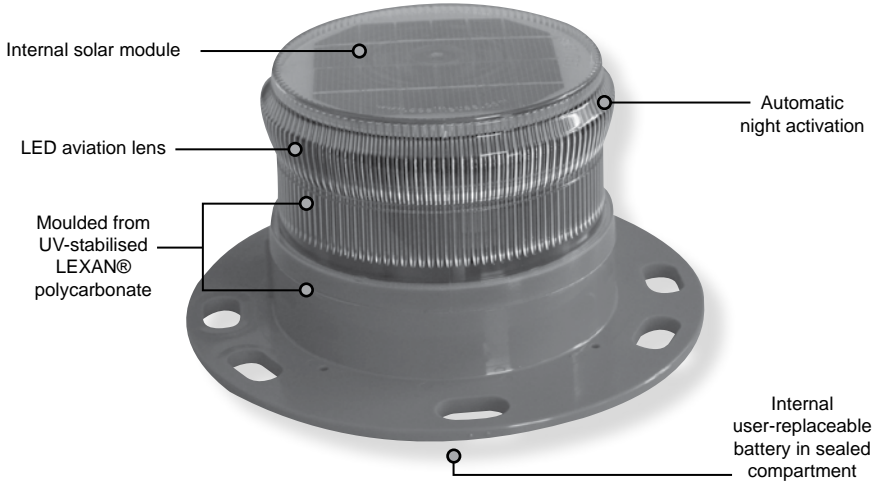

Table of Contents

Introduction	Page 4
Operating Principle	Page 4
Technology	Page 4
AV-60 Model	Page 5
Installation	Page 7
Selecting an Intensity/Power Setting	Page 8
Selecting a Flash Code	Page 8
Flash Codes	Page 9
Maintenance and Servicing	Page 14
Troubleshooting	Page 15
Avlite Light Warranty	Page 18

Version No.	Description	Date	Approved
1.2	Manual Update	May 2010	K. Paton
1.3	General update	June 2012	J. Dore
2.0	Update: Product Code	January 2013	J. Dore



Introduction

Congratulations! By choosing to purchase an Avlite light, you have become the owner of one of the most advanced solar LED airfield lights in the world.

Avlite Systems draws on more than 25 years experience in the design and manufacture of navigation aids, and particular care has been taken to ensure your light gives years of trouble free service.

As a commitment to producing the highest quality products for our customers, Avlite has been independently certified as complying with the requirements of ISO 9001:2008 quality management system.

By taking a few moments to browse through this booklet, you will become familiar with the versatility of your light, and be able to maximise its operating function.

Please remember to complete the Avlite warranty registration card accompanying your light.

Operating Principle

The solar module of the light converts sunlight to an electrical current that is used to charge the battery. The battery provides power to operate the light at night.

The flasher unit has very low current requirements. A microprocessor drives an array of ultra bright LED's through a DC/DC converter, which enables the LED's to operate within the manufacturer's specifications. The battery is protected from over-charging within the circuit to ensure maximum battery life.

On darkness, the microprocessor will initiate a program check and after approximately 1 minute will turn on.

Technology

Avlite Systems is a world-class solar lighting systems manufacturer with a proven reputation for rapid, innovative, and agile technology solutions designed specifically for defense, government, civil and humanitarian aid operations in the most remote, toughest environments.

Electronics

Avlite employs leading in-house electronic engineers in the design and development of software and related circuitry. All individual electronic components are sourced directly by Avlite procurement staff ensuring that only the highest quality components are used in our products.

LED Technology

All aviation lights use the latest advancements in LED (Light Emitting Diode) technology as a light source. The major advantage of LED's over traditional light sources is well established in that they typically have an operational life in excess of 100,000 hours, resulting in substantial savings to maintenance and servicing costs.

Precision Construction

Commitment to investing in the design and construction of injection-moulded parts including optic lenses, light bases and a range of other components ensures that all Avlite products are of a consistent and superior quality.

Optical Performance

Avlite manufactures a range of aviation LED lenses moulded from multi-cavity dies. Complex shapes such as the AV70 and 16-segment multi-focus lenses are a testament to the company's superior in-house lens manufacturing capabilities and outstanding optical performance.

Award-winning, Patented Technology

Several United States and Australian patent registrations are held on Avlite's range of innovative designs, with other regional patents pending in Canada, United Kingdom and Europe.



AV-60 Model

The AV-60 solar LED light provides up to 5.7km visible range (flashing), and is suitable for a variety of applications including taxiway, general hazard, barricade and low-intensity obstruction lighting.

Designed to be maintenance-free and have a service life of up to 12 years, the popular AV-60 model boasts user-adjustable intensity settings and can be set onsite to either steady-on or flashing operation. The light is simply switched 'ON', and the unit is ready for immediate operation. Once installed, the AV-60 requires no operator intervention.



AV-60

Light Characteristics

Light Source

Available colors

Peak Intensity (cd)†

Horizontal Output (degrees)

Vertical Divergence (degrees)

Reflector Type

Available Flash Characteristics

Intensity Adjustments

LED Life Expectancy (hours)

Electrical Characteristics

Operating Voltage (V)

Temperature Range

Solar Characteristics

Solar Module Type

Output (watts)

Solar Module Efficiency (%)

Charging Regulation

Power Supply

Battery Type

Battery Capacity (Ah)

Nominal Voltage (V)

Autonomy (nights)

Physical Characteristics

Body Material

Lens Material

Lens Diameter (mm/inches)

Lens Design

Mounting

Height (mm/inches)

Width (mm/inches)

Mass (kg/lbs)

Product Life Expectancy

Environmental Factors

Humidity

Icing

Wind Speed

Shock

Vibration

Certifications

CE

Quality Assurance

Waterproof

Intellectual Property

Patents

Trademarks

Warranty *

Options Available

6 ultra-high intensity LEDs

Red, Green, White, Yellow, Amber, Blue, Sectored Combinations

Steady-on: Blue - 1.0 Red - 3.3 Green - 5.0 White - 4.4 Yellow - 3.0

Flashing: Blue - 3.3 Red - 7.3 Green - 16.1 White - 14.3 Yellow - 6.9

360

15

Omnidirectional 360° LED Reflector

(US Pat. No. 6,667,582, AU Pat. No. 778,918)

>250 including steady-on (user-adjustable)

Adjustable in 25% increments

>100,000

3.6

-40 to 80°C

Multicrystalline

1.4

14

Microprocessor controlled

High grade NiMH - Environmentally friendly

8

3.6

Steady-on: >20

Flashing: >40 (14 hour darkness, 12.5% duty cycle)

LEXAN® Polycarbonate - UV stabilized

LEXAN® Polycarbonate - UV stabilized

140 / 5½

External optics with interior flute design

6 x 17mm holes on 200mm PCD

120 / 4¾

231 / 9⅛

1.1 / 2⅜

Up to 12 years

0 to 100%, MIL-STD-810F

22kg per square inch

Up to 160kph

MIL-STD-202G, Test Condition G, Method 213B

MIL-STD202G, Test Condition B, Method 204

EN61000-6-3:1997, EN61000-6-1:1997

ISO9001:2008

IP68

US Pat. No. 6,667,582, AU Pat. No. 778,918

AVLITE® is a registered trademark of Avlite Systems

3 year warranty

- IR LEDs
- External ON/OFF Switch

• Specifications subject to change or variation without notice

* Subject to standard terms and conditions

† Intensity setting subject to solar availability



Installation

Charging the Battery

New lights should be left in the sun for 1-2 days to ensure battery is charged before placing in service. Please note, light will re-charge even when toggle switch is turned to 'OFF' position.

Preferred Installation Location

For best light performance, ensure solar modules are not covered and are in clear view of the sky with no shadows.

Light Operation

Light is activated by ON/OFF Switch. Intensity and flash settings need to be set prior to activation.

1. Remove the marked flash adjustment bung from the base of the light and set internal toggle switch to 'ON'.
2. The power and range settings of the light are adjusted by setting the DIP switches inside the light. Your light is normally set to maximum range (see 'Selecting an Intensity/Power Setting' section of this manual).
3. Set rotary switches to the required flash code (see 'Selecting a Flash Code' section of this manual).
4. Replace flash adjustment bung.
5. A sealed vent on the base allows air transfer without moisture intake, and should not be disturbed.
6. To test place dark cover (towel or jacket) on top of light to activate sensor, light will come on within one minute.
7. Ensure that the unit is bolted to an even, flat surface.

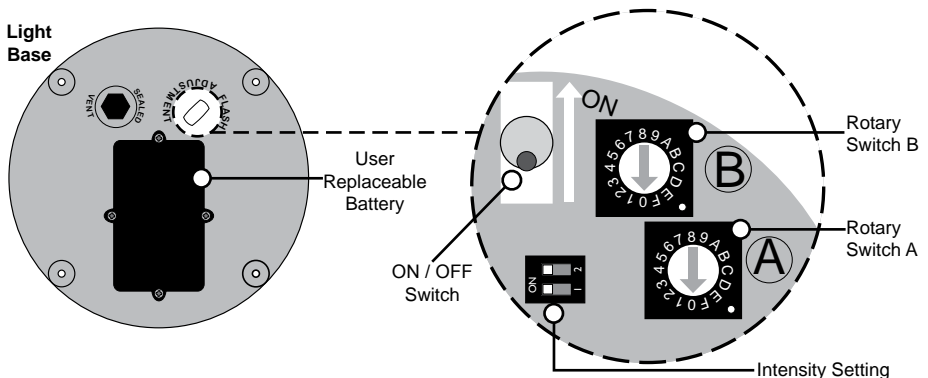

Selecting an Intensity/Power Setting

Intensity/power settings on Avlite lanterns operate via DIP switches, located near the rotary switches on the flasher unit. The intensity/power settings may be used to reduce the power consumption and intensity of the lantern. Setting the lantern to 25% intensity will reduce the power consumption to 25% of the normal 100% setting and the range by 25%. This setting may be used to adjust the current draw of the light to local sunlight conditions.

The following diagrams indicate intensity/power settings:-

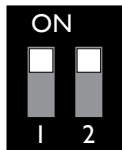

100%

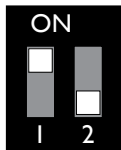

75%

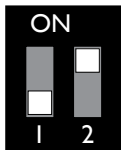

50%

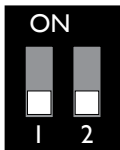

25%

Intensity Setting	Power mA / hour
100%	84-86
75%	63-65
50%	42-44
25%	21.-23

Power Consumption Calculator

Night Hours
(use 13.7 if unknown)

Power
mA/hour

Duty Cycle
(e.g. 20% = 0.2)

Total power used per night
(mA)

	X		X		=	
--	---	--	---	--	---	--

Total power used per night
(mAh)

Solar Panel Charge (mA)

Number of full sunlight hours required to break even
(the amount of time it will take for the solar to replace what the light took out overnight)

	/	176	=		
--	---	-----	---	--	--

If the number of Full Sunlight hours is less than 2.5-3.0 hours, please consider reducing the intensity (Power) or reducing the Duty Cycle.

Selecting a Flash Code - Rotary Switches A & B

All lights have 2 rotary switches marked A and B on the flasher unit. Turning the small arrows to the appropriate number or letter will set the code (see 'Flash Codes' section, of this manual). The unit may take up to one minute to activate a new flash code. A comprehensive list of available flash codes is listed on pages in the 'Flash Codes' section of this manual.

Example:

SWITCH		FLASH CODE	ON	OFF
A	B			
A	0	FL 3 S	0.3	2.7





Flash Codes

AVLITE® code reference is listed by number of flashes

**For the latest version of this document visit www.avlite.com,
or email support@avlite.com**

Symbols

FL	Flash followed by number Eg. FL 1 S, one flash every second
F	Fixed
Q	Quick flash
VQ	Very quick flash
OC	Occulting; greater period on than off
ISO	Isophase; equal period on and off
LFL	Long flash long
MO	Morse code () contains letter

For example, VQ (6) + LFL 10 S means 6 very quick flashes followed by a long flash, during a 10-second interval.

The amount of power your light draws through the night depends on the duty cycle, i.e. the amount of time on as a proportion to the timing cycle. For example, 0.5 seconds on and 4.5 seconds off equals a 10% duty cycle.

It is best to operate at the lowest duty cycle appropriate to the actual needs of the application.

Please note, Avlite models will retain full autonomy in normal operating conditions with duty-cycles up to approximately 30%. In applications whereby duty cycles exceed this limit, a reduction in light intensity is recommended. Please contact a Avlite consultant if assistance is required.

SWITCH	FLASH CODE	ON	OFF
A	B		
0	0 F (Steady light)		
D	3 VQ 0.5 S	0.2	0.3
E	3 VQ 0.6 S	0.2	0.4
F	3 VQ 0.6 S	0.3	0.3
7	3 Q 1 S	0.2	0.8
8	3 Q 1 S	0.3	0.7
9	3 Q 1 S	0.4	0.6
A	3 Q 1 S	0.5	0.5
8	4 Q 1 S	0.8	0.2
B	3 Q 1.2 S	0.3	0.9
9	4 Q 1.2 S	0.5	0.7
C	3 Q 1.2 S	0.6	0.6
F	4 FL 1.5 S	0.2	1.3
1	0 FL 1.5 S	0.3	1.2
0	5 FL 1.5 S	0.4	1.1
0	4 FL 1.5 S	0.5	1.0
2	0 FL 2 S	0.2	1.8
3	0 FL 2 S	0.3	1.7
4	0 FL 2 S	0.4	1.6
5	0 FL 2 S	0.5	1.5
6	0 FL 2 S	0.7	1.3
7	0 FL 2 S	0.8	1.2
1	2 ISO 2 S	1.0	1.0
8	0 FL 2.5 S	0.3	2.2
9	0 FL 2.5 S	0.5	2.0
D	6 FL 2.5 S	1.0	1.5
1	5 FL 3 S	0.2	2.8
A	0 FL 3 S	0.3	2.7
2	5 FL 3 S	0.4	2.6
B	0 FL 3 S	0.5	2.5
3	5 FL 3 S	0.6	2.4
C	0 FL 3 S	0.7	2.3
D	0 FL 3 S	1.0	2.0
2	2 ISO 3 S	1.5	1.5
5	4 OC 3 S	2.0	1.0
E	2 OC 3 S	2.5	0.5
4	6 OC 3.5 S	2.5	1.0
4	5 FL 4 S	0.2	3.8
5	5 FL 4 S	0.3	3.7
E	0 FL 4 S	0.4	3.6
F	0 FL 4 S	0.5	3.5
6	5 FL 4 S	0.6	3.4
0	1 FL 4 S	0.8	3.2
1	1 FL 4 S	1.0	3.0
2	1 FL 4 S	1.5	2.5
3	2 ISO 4 S	2.0	2.0
3	6 OC 4 S	2.5	1.5
F	2 OC 4 S	3.0	1.0
3	1 FL 4.3 S	1.3	3.0
8	5 FL 5 S	0.2	4.8
4	1 FL 5 S	0.3	4.7
5	1 FL 5 S	0.5	4.5
9	5 FL 5 S	0.9	4.1
6	1 FL 5 S	1.0	4.0

SWITCH	FLASH CODE	ON	OFF
A	B		
7	1 FL 5 S	1.5	3.5
4	2 ISO 5 S	2.5	2.5
8	2 LFL 5 S	2.0	3.0
0	3 OC 5 S	3.0	2.0
1	3 OC 5 S	4.0	1.0
2	3 OC 5 S	4.5	0.5
C	6 FL 6 S	0.2	5.8
B	5 FL 6 S	0.3	5.7
C	5 FL 6 S	0.4	5.6
8	1 FL 6 S	0.5	5.5
9	1 FL 6 S	0.6	5.4
A	1 FL 6 S	1.0	5.0
7	5 FL 6 S	1.2	4.8
B	1 FL 6 S	1.5	4.5
5	2 ISO 6 S	3.0	3.0
9	2 LFL 6 S	2.0	4.0
6	4 OC 6 S	4.0	2.0
3	3 OC 6 S	4.5	1.5
4	3 OC 6 S	5.0	1.0
A	4 FL 7 S	1.0	6.0
9	6 FL 7 S	2.0	5.0
5	6 OC 7 S	4.5	2.5
D	5 FL 7.5 S	0.5	7.0
C	1 FL 7.5 S	0.8	6.7
E	5 FL 8 S	0.5	7.5
B	4 FL 8 S	1.0	7.0
6	2 ISO 8 S	4.0	4.0
A	2 LFL 8 S	2.0	6.0
6	6 OC 8 S	5.0	3.0
B	2 LFL 8 S	3.0	5.0
F	5 FL 9 S	0.9	8.1
C	4 FL 9 S	1.0	8.0
7	6 OC 9 S	6.0	3.0
0	6 FL 10 S	0.2	9.8
1	6 FL 10 S	0.3	9.7
D	1 FL 10 S	0.5	9.5
2	6 FL 10 S	0.8	9.2
E	1 FL 10 S	1.0	9.0
1	4 FL 10 S	1.5	8.5
C	2 LFL 10 S	2.0	8.0
D	2 LFL 10 S	3.0	7.0
7	2 ISO 10 S	5.0	5.0
2	4 LFL 10 S	4.0	6.0
8	6 OC 10 S	6.0	4.0
5	3 OC 10 S	7.0	3.0
6	3 OC 10 S	7.5	2.5
F	1 FL 12 S	1.2	10.8
D	4 FL 12 S	2.5	9.5
3	4 LFL 12 S	2.0	10.0
0	2 FL 15 S	1.0	14.0
4	4 LFL 15 S	4.0	11.0
7	4 OC 15 S	10	5.0
A	6 LFL 20 S	2.0	18.0
E	4 FL 26 S	1.0	25.0

SWITCH	FLASH CODE	ON	OFF	ON	OFF
A	B				
0	A FL (2) 4 S	0.5	1.0	0.5	2.0
E	B VQ (2) 4 S	0.2	1.0	0.2	2.6
1	A FL (2) 4.5 S	0.3	1.0	0.3	2.9
2	A FL (2) 4.5 S	0.4	1.0	0.4	2.7
3	A FL (2) 4.5 S	0.5	1.0	0.5	2.5
F	9 FL (2) 5 S	0.2	0.8	0.2	3.8
2	C FL (2) 5 S	0.2	1.2	0.2	3.4
4	A FL (2) 5 S	0.4	0.6	0.4	3.6
0	7 FL (2) 5 S	0.5	1.0	0.5	3.0
1	7 FL (2) 5 S	1.0	1.0	1.0	2.0
9	B Q (2) 5 S	0.3	0.7	0.3	3.7
2	9 Q (2) 5 S	0.5	0.5	0.5	3.5
5	A FL (2) 5.5 S	0.4	1.4	0.4	3.3
7	8 FL (2) 6 S	0.3	0.6	1.0	4.1
A	A FL (2) 6 S	0.3	0.9	0.3	4.5
6	A FL (2) 6 S	0.3	1.0	0.3	4.4
7	A FL (2) 6 S	0.4	1.0	0.4	4.2
9	9 FL (2) 6 S	0.5	1.0	0.5	4.0
2	8 FL (2) 6 S	0.8	1.2	0.8	3.2
3	7 FL (2) 6 S	1.0	1.0	1.0	3.0
3	9 Q (2) 6 S	0.3	0.7	0.3	4.7
A	9 FL (2) 7 S	1.0	1.0	1.0	4.0
7	B FL (2) 8 S	0.4	0.6	2.0	5.0
8	A FL (2) 8 S	0.4	1.0	0.4	6.2
4	7 FL (2) 8 S	0.5	1.0	0.5	6.0
8	8 FL (2) 8 S	0.8	1.2	2.4	3.6
5	7 FL (2) 8 S	1.0	1.0	1.0	5.0
4	C OC (2) 8 S	3.0	2.0	1.0	2.0
5	C OC (2) 8 S	5.0	1.0	1.0	1.0
F	B VQ (2) 8 S	0.2	1.0	0.2	6.6
9	A FL (2) 10 S	0.4	1.6	0.4	7.6
9	8 FL (2) 10 S	0.5	0.5	1.5	7.5
6	7 FL (2) 10 S	0.5	1.0	0.5	8.0
7	7 FL (2) 10 S	0.5	1.5	0.5	7.5
6	9 FL (2) 10 S	0.5	2.0	0.5	7.0
8	7 FL (2) 10 S	0.8	1.2	0.8	7.2
B	9 FL (2) 10 S	1.0	1.0	1.0	7.0
9	7 FL (2) 10 S	1.0	1.5	1.0	6.5
4	9 Q (2) 10 S	0.6	0.4	0.6	8.4
B	A FL (2) 12 S	0.4	1.0	0.4	10.2
C	9 FL (2) 12 S	0.5	1.0	0.5	10.0
D	9 FL (2) 12 S	1.5	2.0	1.5	7.0
A	8 FL (2) 15 S	0.5	1.5	2.0	11.0
A	7 FL (2) 15 S	1.0	2.0	1.0	11.0
8	B Q (2) 15 S	0.2	0.8	0.2	13.8
C	A FL (2) 20 S	1.0	3.0	1.0	15.0
D	A FL (2) 25 S	1.0	1.0	1.0	22.0

SWITCH	FLASH CODE	ON	OFF	ON	OFF	ON	OFF
A	B						
7	9 Q (3) 5 S	0.5	0.5	0.5	0.5	0.5	2.5
5	9 VQ (3) 5 S	0.2	0.3	0.2	0.3	0.2	3.8
0	C VQ (3) 5 S	0.3	0.2	0.3	0.2	0.3	3.7
E	9 VQ (3) 5 S	0.3	0.3	0.3	0.3	0.3	3.5
3	C FL (3) 6 S	0.5	1.0	0.5	1.0	0.5	2.5
2	B FL (2+1) 6 S	0.3	0.4	0.3	1.2	0.3	3.5

SWITCH	FLASH CODE	ON	OFF	ON	OFF	ON	OFF	
A	B							
A	B	Q (3) 6 S	0.3	0.7	0.3	0.7	0.3	3.7
F	A	FL (3) 8 S	0.5	1.0	0.5	1.0	0.5	4.5
0	B	FL (3) 9 S	0.3	1.0	0.3	1.0	0.3	6.1
B	7	FL (3) 9 S	0.8	1.2	0.8	1.2	0.8	4.2
B	8	FL (3) 10 S	0.3	0.7	0.3	0.7	0.9	7.1
C	8	FL (3) 10 S	0.4	0.6	0.4	0.6	1.2	6.8
C	B	FL (3) 10 S	0.5	0.5	0.5	0.5	0.5	7.5
C	7	FL (3) 10 S	0.5	1.5	0.5	1.5	0.5	5.5
D	B	FL (3) 10 S	0.6	0.6	0.6	0.6	0.6	7.0
D	7	FL (3) 10 S	1.0	1.0	1.0	1.0	1.0	5.0
3	8	FL (2+1) 10 S	0.5	0.7	0.5	2.1	0.5	5.7
8	9	OC (3) 10 S	5.0	1.0	1.0	1.0	1.0	1.0
B	B	Q (3) 10 S	0.3	0.7	0.3	0.7	0.3	7.7
D	8	FL (2 + 1) 10 S	0.5	0.5	0.5	0.5	1.5	6.5
1	B	FL (3) 12 S	0.5	1.5	0.5	1.5	0.5	7.5
E	A	FL (3) 12 S	0.5	2.0	0.5	2.0	0.5	6.5
E	7	FL (3) 12 S	0.8	1.2	0.8	1.2	0.8	7.2
B	6	FL (3) 12 S	1.0	1.0	1.0	3.0	1.0	5.0
4	8	FL (2+1) 12 S	0.8	1.2	0.8	2.4	0.8	6.0
5	8	FL (2+1) 12 S	1.0	1.0	1.0	4.0	1.0	4.0
1	8	FL (2+1) 13.5 S	1.0	1.0	1.0	4.0	1.0	5.5
F	7	FL (3) 15 S	0.3	1.7	0.3	1.7	0.3	10.7
9	D	FL (3) 15 S	0.4	1.0	0.4	1.0	0.4	11.8
0	8	FL (3) 15 S	0.5	1.5	0.5	1.5	0.5	10.5
F	8	FL (2+1) 15 S	0.6	0.3	0.6	0.3	1.4	11.8
0	9	FL (2+1) 15 S	0.7	0.5	0.7	0.5	1.9	10.7
1	9	FL (2+1) 15 S	0.7	0.7	0.7	0.7	2.1	10.1
6	8	FL (2+1) 15 S	1.0	2.0	1.0	5.0	1.0	5.0
1	C	VQ (3) 15 S	0.1	0.5	0.1	0.5	0.1	13.7
4	B	FL (3) 20 S	0.5	3.0	0.5	3.0	0.5	12.5
3	B	FL (3) 20 S	0.5	1.5	0.5	1.5	0.5	15.5
5	B	FL (3) 20 S	0.8	1.2	0.8	1.2	0.8	15.2
6	B	FL (3) 20 S	1.0	1.0	1.0	1.0	1.0	15.0

SWITCH	FLASH CODE	ON	OFF	ON	OFF	ON	OFF	ON	OFF
A	B								
B	F	VQ (4) 4 S	0.3	0.3	0.3	0.3	0.3	0.3	2.3
B	D	Q (4) 6 S	0.3	0.7	0.3	0.7	0.3	0.7	2.7
8	D	Q (4) 6 S	0.4	0.6	0.4	0.6	0.4	0.6	2.6
1	D	FL (4) 10 S	0.5	1.0	0.5	1.0	0.5	1.0	5.0
2	D	FL (4) 10 S	0.8	1.2	0.8	1.2	0.8	1.2	3.2
F	E	Q (4) 10 S	0.3	0.7	0.3	0.7	0.3	0.7	6.7
B	E	FL (4) 12 S	0.3	1.7	0.3	1.7	0.3	1.7	5.7
4	F	FL (4) 12 S	0.5	0.5	0.5	0.5	0.5	0.5	8.5
C	E	FL (4) 12 S	0.5	1.5	0.5	1.5	0.5	1.5	5.5
3	D	FL (4) 12 S	0.8	1.2	0.8	1.2	0.8	1.2	5.2
A	D	Q (4) 12 S	0.3	0.7	0.3	0.7	0.3	0.7	8.7
4	D	FL (4) 15 S	0.5	1.5	0.5	1.5	0.5	1.5	8.5
8	E	FL (4) 15 S	1.0	1.0	1.0	1.0	1.0	1.0	8.0
7	D	FL (4) 15 S	1.5	0.5	0.5	0.5	0.5	0.5	10.5
D	E	FL (4) 16 S	0.5	1.5	0.5	1.5	0.5	1.5	9.5
C	D	FL (4) 20 S	0.3	3.0	0.3	3.0	0.3	3.0	9.8
5	D	FL (4) 20 S	0.5	1.5	0.5	1.5	0.5	1.5	13.5
0	D	FL (4) 20 S	0.5	1.5	0.5	1.5	0.5	4.5	10.5
3	F	FL (4) 20 S	1.5	1.5	1.5	1.5	1.5	1.5	9.5
0	F	Q (4) 20 S	0.5	0.5	0.5	0.5	0.5	0.5	16.5
E	E	Q (4) 28 S	0.5	0.5	0.5	0.5	0.5	0.5	24.5
6	F	FL (4) 30 S	0.5	0.5	0.5	0.5	0.5	0.5	26.5

SWITCH	FLASH CODE	ON	OFF	ON	OFF	ON	OFF	ON	OFF	ON	OFF	
A	B											
D	D	Q (5) 7 S	0.3	0.7	0.3	0.7	0.3	0.7	0.3	0.7	0.3	2.7
E	D	Q (5) 10 S	0.3	0.7	0.3	0.7	0.3	0.7	0.3	0.7	0.3	5.7
E	8	FL (5) 12 S	0.5	1.5	0.5	1.5	0.5	1.5	0.5	1.5	0.5	3.5
5	F	FL (5) 20 S	0.5	0.5	0.5	0.5	0.5	0.5	0.5	0.5	0.5	15.5
9	F	FL (5) 20 S	0.8	1.2	0.8	1.2	0.8	1.2	0.8	1.2	0.8	11.2
9	E	FL (5) 20 S	1.0	1.0	1.0	1.0	1.0	1.0	1.0	1.0	1.0	11.0

SWITCH	FLASH CODE	ON	OFF	ON	OFF	ON	OFF	ON	OFF	ON	OFF	ON	OFF
A	B												
F	D	Q (6) 10 S	0.3	0.7	0.3	0.7	0.3	0.7	0.3	0.7	0.3	0.7	4.7
A	F	FL (6) 15 S	0.3	0.7	0.3	0.7	0.3	0.7	0.3	0.7	0.3	0.7	9.7
7	F	FL (6) 15 S	0.5	1.0	0.5	1.0	0.5	1.0	0.5	1.0	0.5	1.0	7.0

SWITCH	FLASH CODE	ON	OFF	ON	OFF	ON	OFF	ON	OFF	ON	OFF	ON	OFF	ON	OFF	
A	B															
6	E	VQ (6) + LFL 10 S	0.2	0.3	0.2	0.3	0.2	0.3	0.2	0.3	0.2	0.3	0.2	0.3	2.0	5.0
7	E	VQ (6) + LFL 10 S	0.3	0.3	0.3	0.3	0.3	0.3	0.3	0.3	0.3	0.3	0.3	0.3	2.0	4.4
2	F	Q (6) + LFL 15 S	0.2	0.8	0.2	0.8	0.2	0.8	0.2	0.8	0.2	0.8	0.2	0.8	2.0	7.0
2	E	Q (6) + LFL 15 S	0.3	0.7	0.3	0.7	0.3	0.7	0.3	0.7	0.3	0.7	0.3	0.7	2.0	7.0
3	E	Q (6) + LFL 15 S	0.6	0.6	0.6	0.6	0.6	0.6	0.6	0.6	0.6	0.6	0.6	0.6	2.0	5.8
8	F	VQ (6) + LFL 15 S	0.3	0.3	0.3	0.3	0.3	0.3	0.3	0.3	0.3	0.3	0.3	0.3	2.0	9.4

SWITCH	FLASH CODE	ON	OFF	ON	OFF	ON	OFF	ON	OFF	ON	OFF	ON	OFF	ON	OFF	ON	OFF	
A	B																	
4	E	VQ (9) 10 S	0.2	0.3	0.2	0.3	0.2	0.3	0.2	0.3	0.2	0.3	0.2	0.3	0.2	0.3	0.2	5.8
5	E	VQ (9) 10 S	0.3	0.3	0.3	0.3	0.3	0.3	0.3	0.3	0.3	0.3	0.3	0.3	0.3	0.3	0.3	4.9
1	F	Q (9) 15 S	0.2	0.8	0.2	0.8	0.2	0.8	0.2	0.8	0.2	0.8	0.2	0.8	0.2	0.8	0.2	6.8
0	E	Q (9) 15 S	0.3	0.7	0.3	0.7	0.3	0.7	0.3	0.7	0.3	0.7	0.3	0.7	0.3	0.7	0.3	6.7
1	E	Q (9) 15 S	0.6	0.6	0.6	0.6	0.6	0.6	0.6	0.6	0.6	0.6	0.6	0.6	0.6	0.6	0.6	4.8

SWITCH	FLASH CODE	ON	OFF	ON	OFF	ON	OFF	ON	OFF
A	B								
MORSE CODE () INDICATES LETTER									
7	8	MO (A) 6 S	0.3	0.6	1.0	4.1			
7	B	MO (A) 8 S	0.4	0.6	2.0	5.0			
8	8	MO (A) 8 S	0.8	1.2	2.4	3.6			
B	8	MO (U) 10 S	0.3	0.7	0.3	0.7	0.9	7.1	
C	8	MO (U) 10 S	0.4	0.6	0.4	0.6	1.2	6.8	
D	8	MO (U) 10 S	0.5	0.5	0.5	0.5	1.5	6.5	
9	8	MO (A) 10 S	0.5	0.5	1.5	7.5			
8	9	MO (D) 10 S	5.0	1.0	1.0	1.0	1.0	1.0	
A	8	MO (A) 15 S	0.5	1.5	2.0	11.0			
F	8	MO (U) 15 S	0.6	0.3	0.6	0.3	1.4	11.8	
0	9	MO (U) 15 S	0.7	0.5	0.7	0.5	1.9	10.7	
1	9	MO (U) 15 S	0.7	0.7	0.7	0.7	2.1	10.1	
7	D	MO (B) 15 S	1.5	0.5	0.5	0.5	0.5	0.5	10.5

Maintenance and Servicing

Designed to be maintenance free, the AV-60 requires minimal attention, though the following maintenance and servicing information is provided to help ensure the life of your Avlite product.

1. **Cleaning Solar Panels** - occasional cleaning of the solar panels may be required. Using a cloth and warm soapy water, wipe off any foreign matter before rinsing the panels with fresh water.
2. **Battery Check** - inspection of batteries should be performed every three years (minimum) to ensure that the charger, battery and ancillary electronics are functioning correctly. Using a voltage meter, check that the battery voltage is at least 3.6 volts under 100mA load, and ensure all terminals are clear of foreign matter.

Replacing the battery- Don't throw the unit out!!

The AV-60 lights are the only compact aviation light with a double sealed battery compartment. This provides the user with the ability to change the battery after years of operation.

1. Remove the marked flash adjustment bung from the base of the light and set internal toggle switch to 'OFF'.
2. Unscrew small screws to remove battery plate.
3. Remove battery from AV-60 case and unscrew positive and negative leads.
4. Discard old battery in a safe manner.
5. Reattach positive and negative leads to new battery and then place back into case.
6. Reattach battery plate and switch light 'ON' via internal switch. Close the bung.
7. To test place dark cover (towel or jacket) on top of light to activate sensor, light will come on within one minute.

Care must be taken to observe the polarity of the battery before the leads are re-connected, and ensure the replacement battery is correctly fitted. Always discard old batteries in a safe manner.

Long Term Storage Instructions

If the AV-60 is to be placed in storage for an extended period, being more than 5 months, please follow the below steps.

1. The 3.6V NiMH Battery must be stored in a fully charged condition.
2. Remove the Flash Adjustment plug and turn the ON/OFF switch to the OFF position.
3. Remove the battery cover and disconnect the Positive (+) Terminal.
4. Fold the Terminal away from the Negative Battery Terminal.
5. Replace the Battery Cover
6. Replace the Flash Adjustment Plug.

All batteries will discharge over time and the rate of discharge is dependent on temperature. If the light is being stored in temperatures greater than 40°C the battery will discharge faster.

Please check battery every 3-6 months and recharge if necessary.

Recharging the Battery

1. Remove the Battery Cover and connect the Positive Terminal.
2. Remove the Flash Adjustment Plug and turn the ON/OFF switch to the ON position.
3. Reconnect the battery and place unit in the sun for 2-4 days

Or

Reconnect battery and place in front of a halogen lamp for 2-3 days. (Do not place the halogen light too close to the solar panel or the panel may be overheated)

Check the battery voltage regularly to make sure the unit is charging correctly.

After the battery has been recharged, switch the light OFF.

Trouble Shooting

Problem	Remedy
Light will not activate.	<ul style="list-style-type: none"> • Ensure internal toggle switch is set to the 'ON position. • Ensure light is in darkness. • Wait at least 60 seconds for the program to initialise in darkness. • Ensure switch setting is on a valid code (See <i>Flash Codes</i> section of this manual). • Ensure battery terminals are properly connected. • Ensure battery voltage is above 3.6volts.
Timing codes will not change.	<ul style="list-style-type: none"> • Turn rotary switches several times to ensure contacts are clear.
Light will not operate for the entire night.	<ul style="list-style-type: none"> • Expose light to direct sunlight and monitor operation for several days. Avlite products typically require 1.5 hours of direct sunlight per day to retain full autonomy. From a discharged state, the light may require several days of operational conditions to 'cycle' up to full autonomy. • Reducing the light output intensity or duty cycle (flash code) will reduce current draw on the battery. • Ensure solar module is clean and not covered by shading during the day.
Light is constantly on during the day.	<ul style="list-style-type: none"> • Ensure the flash code is not set to F F. This flash code is for testing purposes only and will be steady on for 24 hours a day.



Notes



Notes



Avlite Light Warranty V1.1

Activating the Warranty

Upon purchase, the Avlite Systems warranty must be activated for recognition of future claims. To do this you have two (2) options:

1. **Postal Registration**

Please complete the Avlite Systems Warranty Registration Card and return to Avlite within 30 days of your purchase.

2. **Online Registration**

Please complete the Online Registration Form at; www.avlite.com

Avlite Systems will repair or replace your lantern in the event of electronic failure for a period of up to three years from the date of purchase.

The unit must be returned to Avlite freight prepaid.

Warranty Terms

1. Avlite Systems warrants that any Avlite aviation products fitted with telemetry equipment including but not limited to AIS, GSM, GPS or RF ("Telemetry Products") will be free from defective materials and workmanship under normal and intended use, subject to the conditions hereinafter set forth, for a period of twelve (12) months from the date of purchase by the original purchaser.
2. Avlite Systems warrants that any rotationally-moulded products ("Roto-Moulded Products") and accessory products ("Accessory Products") will be free from defective materials and workmanship under normal and intended use, subject to the conditions hereinafter set forth, for a period of twelve (12) months from the date of purchase by the original purchaser.
3. Avlite Systems warrants that any Avlite aviation products other than the Telemetry Products, Roto-Moulded Products and Accessory Products ("Avlite Products") will be free from defective materials and workmanship under normal and intended use, subject to the conditions hereinafter set forth, for a period of three (3) years from the date of purchase by the original purchaser.
4. Avlite Systems will repair or replace, at Avlite's sole discretion, any Telemetry Products, Roto-Moulded Products, Accessory Products or Avlite Products found to be defective in material and workmanship in the relevant warranty period so long as the Warranty Conditions (set out below) are satisfied.
5. If any Telemetry Products or Avlite Products are fitted with a rechargeable battery, Avlite Systems warrants the battery will be free from defect for a period of one (1) year when used within original manufacturer's specifications and instructions.

Warranty Conditions

This Warranty is subject to the following conditions and limitations;

1. The warranty is applicable to lanterns manufactured from 1/1/2009.
2. The warranty is void and inapplicable if:
 - a. the product has been used or handled other than in accordance with the instructions in the owner's manual and any other information or instructions provided to the customer by Avlite;
 - b. the product has been deliberately abused, or misused, damaged by accident or neglect or in being transported; or
 - c. the defect is due to the product being repaired or tampered with by anyone other than Avlite or authorised Avlite repair personnel.
3. The customer must give Avlite Systems notice of any defect with the product within 30 days of the customer becoming aware of the defect.
4. Rechargeable batteries have a limited number of charge cycles and may eventually need to be replaced. Typical battery replacement period is 3-4 years. Long term exposure to high temperatures will shorten the battery life. Batteries used or stored in a manner inconsistent with the manufacturer's specifications and instructions shall not be covered by this warranty.



5. No modifications to the original specifications determined by Avlite shall be made without written approval of Avlite Systems.
6. Avlite lights can be fitted with 3rd party power supplies and accessories but are covered by the 3rd party warranty terms and conditions.
7. The product must be packed and returned to Avlite Systems by the customer at his or her sole expense. Avlite Systems will pay return freight of its choice. A returned product must be accompanied by a written description of the defect and a photocopy of the original purchase receipt. This receipt must clearly list model and serial number, the date of purchase, the name and address of the purchaser and authorised dealer and the price paid by the purchaser. On receipt of the product, Avlite Systems will assess the product and advise the customer as to whether the claimed defect is covered by this warranty.
8. Avlite Systems reserves the right to modify the design of any product without obligation to purchasers of previously manufactured products and to change the prices or specifications of any product without notice or obligation to any person.
9. Input voltage shall not exceed those recommended for the product.
10. Warranty does not cover damage caused by the incorrect replacement of battery in solar lantern models.
11. This warranty does not cover any damage or defect caused to any product as a result of water flooding or any other acts of nature.
12. There are no representations or warranties of any kind by Avlite or any other person who is an agent, employee, or other representative or affiliate of Avlite, express or implied, with respect to condition of performance of any product, their merchantability, or fitness for a particular purpose, or with respect to any other matter relating to any products.

Limitation of Liability

To the extent permitted by section 68A of the Trade Practices Act 1974 (Cth), the liability of Avlite Systems under this Warranty will be, at the option of Avlite Systems, limited to either the replacement or repair of any defective product covered by this Warranty. Avlite Systems will not be liable to Buyer for consequential damages resulting from any defect or deficiencies in accepted items.

Limited to Original Purchaser

This Warranty is for the sole benefit of the original purchaser of the covered product and shall not extend to any subsequent purchaser of the product.

Miscellaneous

Apart from the specific warranties provided under this warranty, all other express or implied warranties relating to the above product is hereby excluded to the fullest extent allowable under law. The warranty does not extend to any lost profits, loss of good will or any indirect, incidental or consequential costs or damages or losses incurred by the purchaser as a result of any defect with the covered product.

Warrantor

Avlite Systems has authorised distribution in many countries of the world. In each country, the authorised importing distributor has accepted the responsibility for warranty of products sold by distributor. Warranty service should normally be obtained from the importing distributor from whom you purchased your product. In the event of service required beyond the capability of the importer, Avlite Systems will fulfil the conditions of the warranty. Such product must be returned at the owner's expense to the Avlite Systems factory, together with a photocopy of the bill of sale for that product, a detailed description of the problem, and any information necessary for return shipment.

Other Avlite Products Available



Solar Aviation Lighting



**Radio Controlled &
PALC Systems (FCC Compliant)**



**Obstruction Lighting
(LIOL A & LIOL B)**



**Airfield Markers
& Accessories**

Typical Applications

- Temporary & permanent airfield lighting
- Remote, emergency & defence airfield lighting
 - Barricade, hazard & perimeter lighting
 - Helipad lighting
- Obstruction lighting

For a complete list of product compliances including ICAO & FAA, please contact Avlite today



Area & Sign Lighting



Head Office

Avlite Systems
11 Industrial Drive
Somerville, Vic 3912
Australia

Tel: +61 (0)3 5977 6128
Fax: +61 (0)3 5977 6124

Email: info@avlite.com
Internet: www.avlite.com

A subsidiary of Sealite Pty Ltd www.sealite.com

Solar Aviation Light

AV-60

Features

- Up to 5.7km visible range (flashing), up to 3.7km visible range (steady-on) - color dependant
- Integrated solar/battery system
- IP68 waterproof rating
- User-replaceable battery
- Ultra-high intensity LEDs (no changing globes ever)

Typical Applications

- Solar Barricade Light
- Solar Caution Light
- Solar Hazard Light
- Solar Taxiway Light (ICAO)
- Solar Obstruction Light

Compliance

- FAA AC150/5370-2F for construction and barricade installations
- ICAO Annex 14 Volume 1, 'Aerodrome Design and Operations', paragraph 5.3.17.7.

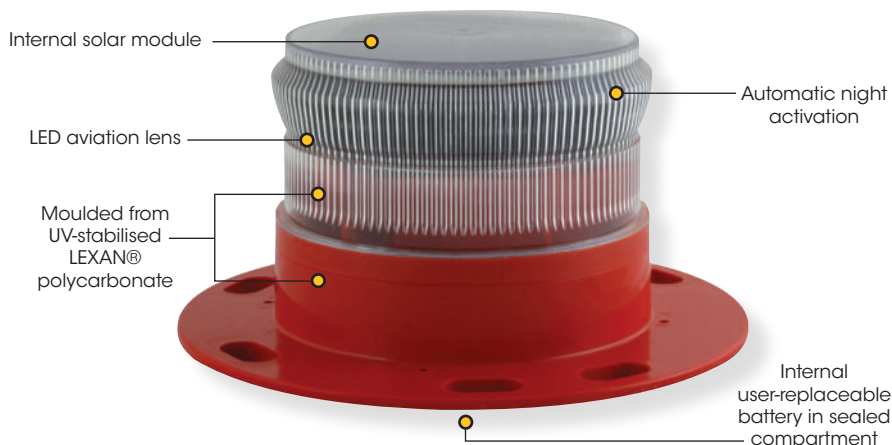

The AV-60 solar LED light provides up to 5.7km visible range (flashing). The positive divergence, wide angle lens makes it suitable for a variety of applications including taxiway, general hazard, barricade and low-intensity obstruction lighting.

Designed to be maintenance-free and have a service life of up to 12 years, the popular AV-60 model boasts user-adjustable intensity settings and can be set onsite to either steady-on or flashing operation. The light is simply switched 'ON', and the unit is ready for immediate operation. Once installed, the AV-60 requires no operator intervention.

The internal solar module charges the battery during daylight hours, and at dusk the light will automatically begin operation once the ambient light threshold drops sufficiently. The battery is housed in a sealed compartment allowing it to be changed after years of service.

Coupled with the latest LED technology, and a highly efficient DC/DC converter, the light may provide over 40 days of continuous operation without sunlight. The AV-60 comes with a large 200mm bolt pattern.

Several thousand AV-60 units are installed throughout Asia, Africa and the Middle East to mark telecommunications towers and other aerial obstructions.

Optional ON/OFF Switch

The AV-60 is also available with an optional external ON/OFF switch; this means, when in position, the light can be turned on with the flick of a switch.



Royal Flying
Doctor Service

Avlite donates AU\$20 to the Royal Flying Doctor Service from the sale of each AV-60 & AV-70 light within Australia



Solar Aviation Light

AV-60

SPECIFICATIONS* *

AV-60

Light Characteristics

Light Source 6 ultra-high intensity LEDs
 Available colors Red, Green, White, Yellow, Amber, Blue, Sectored Combinations
 Peak Intensity (cd)† Steady-on: Blue - 1.0 Red - 3.3 Green - 5.0 White - 4.4 Yellow - 3.0
 Flashing: Blue - 3.3 Red - 7.3 Green - 16.1 White - 14.3 Yellow - 6.9
 Horizontal Output (degrees) 360
 Vertical Divergence (degrees) 15
 Reflector Type Omnidirectional 360° LED Reflector (US Pat. No. 6,667,582, AU Pat. No. 778,918)
 Available Flash Characteristics >250 including steady-on (user-adjustable)
 Intensity Adjustments Adjustable in 25% increments
 LED Life Expectancy (hours) >100,000

Electrical Characteristics

Operating Voltage (V) 3.6
 Temperature Range -40 to 80°C

Solar Characteristics

Solar Module Type Multicrystalline
 Output (watts) 1.4
 Solar Module Efficiency (%) 14
 Charging Regulation Microprocessor controlled

Power Supply

Battery Type High grade NiMH - Environmentally friendly
 Battery Capacity (Ah) 8
 Nominal Voltage (V) 3.6
 Autonomy (nights) Steady-on: >20
 Flashing: >40 (14 hour darkness, 12.5% duty cycle)

Physical Characteristics

Body Material LEXAN® Polycarbonate - UV stabilized
 Lens Material LEXAN® Polycarbonate - UV stabilized
 Lens Diameter (mm/inches) 140 / 5½
 Lens Design External optics with interior flute design
 Mounting 6 x 17mm holes on 200mm PCD
 Height (mm/inches) 120 / 4¾
 Width (mm/inches) 231 / 9⅞
 Mass (kg/lbs) 1.1 / 2⅜
 Product Life Expectancy Up to 12 years

Environmental Factors

Humidity 0 to 100%, MIL-STD-810F
 Icing 22kg per square inch
 Wind Speed Up to 160kph
 Shock MIL-STD-202G, Test Condition G, Method 213B
 Vibration MIL-STD202G, Test Condition B, Method 204

Certifications

CE EN61000-6-3:1997, EN61000-6-1:1997
 Quality Assurance ISO9001:2008
 Waterproof IP68

Intellectual Property

Patents US Pat. No. 6,667,582, AU Pat. No. 778,918
 Trademarks AVLITE® is a registered trademark of Avlite Systems
 3 year warranty

Warranty *

Options Available

• Specifications subject to change or variation without notice
 * Subject to standard terms and conditions
 † Intensity setting subject to solar availability

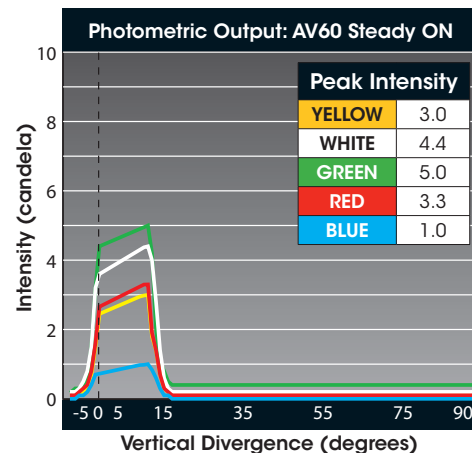

Steady ON, low intensity, wide angle lens

