

MECHANICAL

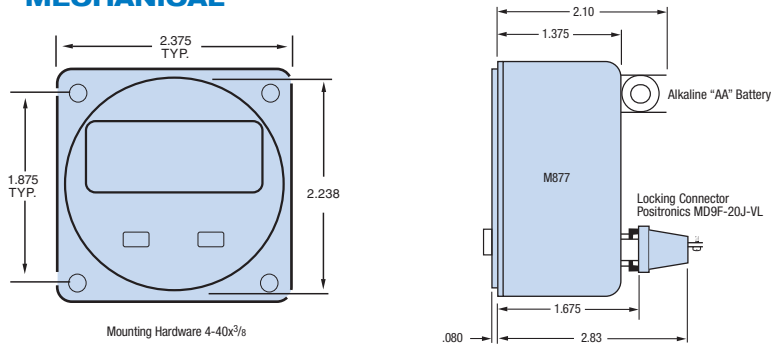

ELECTRICAL

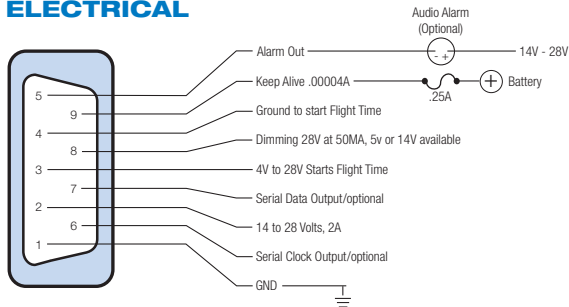

NOTE: Keep Alive (Pin 9) is only required if alkaline AA size battery is removed. Flight Time starts with either Pin 3 or Pin 4 – use only one pin.

SPECIFICATIONS

- **Greenwich Mean Time:** 24 hour format.
- **Local Time:** 12 hour or 24 hour format.
- **Flight Time:** Records in 99:59 standard, 99.99 hour option.
- **Flight Time Alarm:** Full set range flight time.
- **Elapsed Time Count Up:** Starts in minutes, seconds, then hours, minutes up to 99:59 hrs.
- **Elapsed Time Count Down:** Settable from one second to 59 minutes, 59 seconds.
- **Elapsed Time Alarm:** Activates at zero when counting down.
- **Incandescent Displays** Readable in sunlight.
- **Automatic Dimming**
- **Battery Type:** AA size alkaline.
- **Polarizing Filter**
- **Keep Alive Current:** .00004 Amps.
- **Input Current:** .2 Amps.
- **Input Voltage:** 14V - 28V
Backlight available 5V, 14V or 28V lighting. (Specify when ordering)
- **Crystal Reference:** -40C to + 60C .001%.
- **Weight:** 5 ounces.
- **Warranty:** 1 year.

DIGITAL CLOCK

GREENWICH MEAN TIME
LOCAL TIME
FLIGHT TIME - Flight Time Alarm
ELAPSED TIME - Count Up, Count Down, Alarm



M877

Incandescent Display

FEATURES

- Two button control system is natural and error free. Setting operations are identical for both alarm and time setting. Patent Pending.
- Bright sunlight readable incandescent displays.
- Illuminated buttons and annunciators for night viewing.
- Flight Time recorded in hours and minutes or in hours, tenths, and hundredths.
- Serial time data output for remote use.
- Flight time alarm with external output.
- Elapsed time count down timer with alarm.
- Temperature - Compensated crystal oscillator to maintain precision time reference.



427 HILLCREST WAY
REDWOOD CITY (Emerald Hills) CA 94062
(650) 369-1188
www.davtron.com



M877 LSI Aircraft Time Management System

CLOCK OPERATION

Normal Operation

The SEL button selects what is to be displayed in the four digit window and the CTL button controls what is being displayed. Pressing select sequentially selects GMT, Local Time, Flight Time, Elapsed Time and back to GMT. The CTL button starts and resets Elapsed Time when momentarily pushed. Normal operation of the 877 cannot accidentally reset time.

Setting GMT

Select GMT for display in the four digit window with the SEL button. Simultaneously press both the select and control buttons to enter the set mode. The tens of hours digit will start flashing. The control button has full control of the flashing digit and each button push increments the digit. Once the tens of hour is set, the select button selects the next digit to be set. After the last digit has been selected and set with the control button, a final push of the select button exits the mode. The lighted annunciator will resume its normal flashing, indicating the GMT clock is running.

Setting LT

Select Local Time, LT, using the SEL button. Simultaneously push the SEL and CTL buttons to enter set mode. The tens of hours digit will start flashing. The set operation is the same as for GMT, except that minutes are already synchronized with the GMT clock. In enhanced mode, minutes can be changed in 15 minute increments for special time zones.

Control/Select Disable

When there is no aircraft power applied in the clock CTL and SEL buttons are disabled.

Setting Flight Time Alarm

When Flight Time, FT, is displayed enter the set mode by pressing both buttons simultaneously. The alarm time is entered identically to GMT setting. When the Flight Time equals the alarm the display will flash and the alarm output activated. If FT was not being displayed at the time the alarm becomes active, the clock automatically selects FT for display. Pressing either the SEL or CTL button turns off the alarm. Flight Time is unchanged and continues counting.

Flight Time Reset

FT must be displayed when resetting. Hold CTL down for 3 seconds, or until 99:59 Or 99:99 appears on the display. The digits that appear depends on how the clock is programmed. In hour and minutes, or in hours, tenths and hundredths. Flight Time will be zeroed upon release of the CTL button.

Elapsed Time Count Up

Select ET for display. Pressing the CTL button will start ET counting. Elapsed Time counts up to 59 minutes, 59 seconds, and then switches to hours and minutes. It continues counting up to 99 hours and 59 minutes. Pressing the CTL button again resets ET to zero. Enhanced mode allows press on CTL button to stop counting. Second press resets to zero

Elapsed Time Count Down

Select ET for display and enter set mode by pressing both buttons. The countdown timer can now be set. Entering the time is identical to GMT time setting. When the time is entered and the last digit is no longer flashing the clock is ready to start the countdown. Momentarily pressing the CTL button starts the countdown. When count reaches zero the displays flash and the external alarm is activated. Pressing either SEL or CTL will deactivate the alarm. ET continues counting up. Enhanced mode allows press on CTL button to stop counting. Second press resets to zero.

Test Mode

Hold the SEL button down for three seconds and the display will indicate 88:88 and activate all four annunciators.

FIELD OPTION CHANGES

When changes are made the connector of the clock must be grounded to the soldering iron or warranty may be void.

Serial Time Data: To change from GMT to LT, remove case and jumper LT.

Local Time: To change from 12 hour to 24 hour format remove case and jumper Opt-24. Enhanced mode hold SEL in LT mode for 5 seconds till 12 HR or 24 HR flashes, then push CTL for desired format. Push SEL to exit set mode.

Flight Time: To change from recording in hours, minutes to recording in hours, tenths and hundredths, remove case and jumper 99.

Battery Removal: The battery and battery holder may be removed permanently if the aircraft battery is connected to the Keep Alive input (Pin 9). No changes in the clock are required. Recommend to remove AA battery if pin 9 used.

Remote Time Display: Additional time displays can be driven by the M877 clock. Only two wires carry the time information to the remote display. The remote displays have independent automatic dimming. Either GMT or LT may be displayed. Remote display units are available from Davtron, Inc.

Enhanced Mode: Remove case and jumper Opt-1.



Greenwich Mean Time



Local Time



Flight Time



Elapsed Time

STANDARD AND OPTIONAL FEATURES

Local Time 12 or 24 hour format.

Flight Time in standard format of hours, minutes, (99:59) or optional format of hours, tenths and hundredths up to 99:99.

Flight Time Settable Alarm when FT reaches programmed alarm time the display flashes and the external alarm output is activated.

Elapsed Time Count Up counts in minutes and seconds up to 59 minutes and 59 seconds and then changes to hours and minutes up to 99 hours and 59 minutes.

Elapsed Time Count Down may be set to count down anywhere from one second to 59 minutes and 59 seconds.

Elapsed Time Alarm when the count down time entered reaches zero the display flashes and the external alarm output is activated. (Optional)

Serial Time output standard is GMT. (Local Time Optional)

Voltage Input is 28 Volts to 14 Volt. **Battery** is a longlife AA alkaline cell. The recommended change interval is every two years. Keep Alive (Pin 9) must then be connected to aircraft battery. Remove AA battery if pin 9 is used.

Note Battery can be easily removed and replaced without removing clock from aircraft. Battery holder is polarity marked with red end positive (+).