

VOLT / AMP / METER

MODEL 475VA

Features *Low current drain .001 amp *Plus or minus 150.0 amp range
*Plus 100.0 volt D.C. range *2¼" standard mount *1.3" case depth
*14 or 28 volt back lighting *Sunlight readable *One tenth amp resolution
*One tenth volt resolution.

The M475VA and the M475VAA were designed for low current drain and are also used in standby and emergency battery packs.

Note - Shunts can be removed (special order). Extreme care must be taken to fuse wire when using remote shunts. A Model M485VA is made primarily for remote shunts.

M475VA MECHANICAL

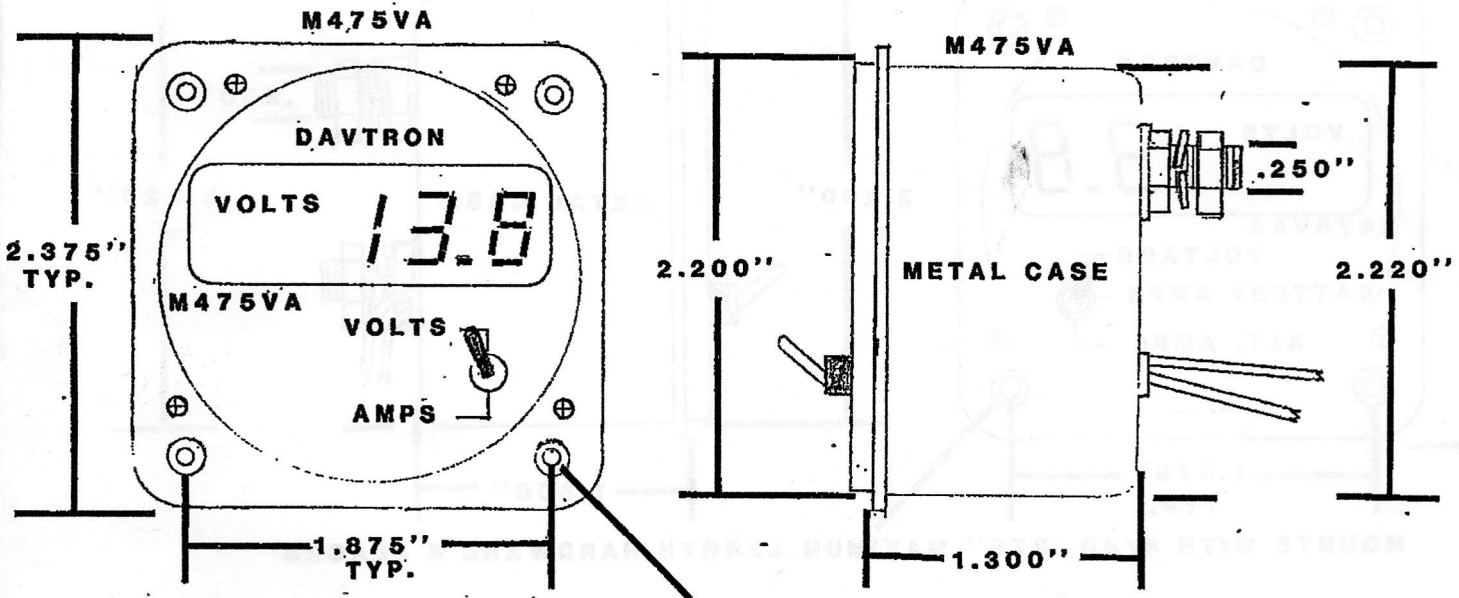

MOUNTS WITH 4/40 BY .375" MAXIMUM LENGTH HARDWARE 4 PLACES

M475VA ELECTRICAL

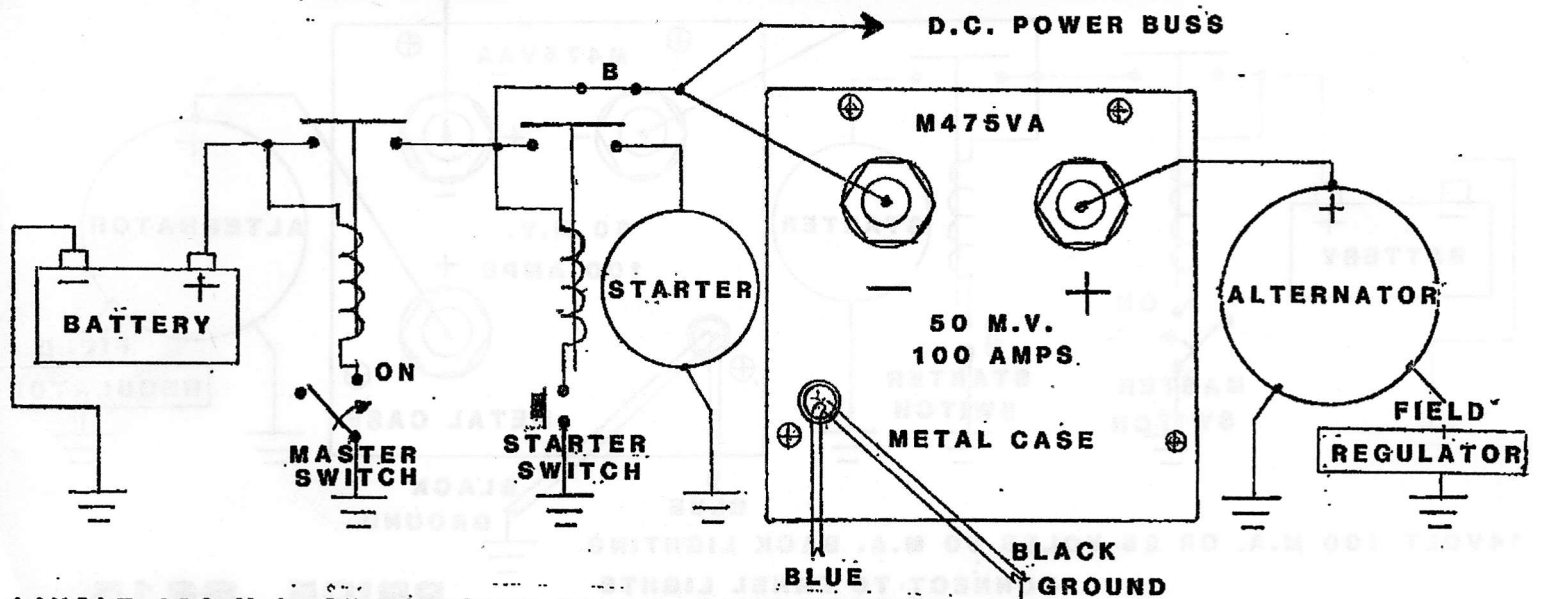

14VOLT 100 M.A. OR 28 VOLTS 50 M.A. BACK LIGHTING

CONNECT TO PANEL LIGHTS

PRICE \$185