

RC-9000

MULTIBAND P25 AIRBORNE TRANSCEIVER REMOTE CONTROL



Installation Instructions

TiL Document No. 13RE480
Rev. n/c
Issue 1

OCT 2013

Technisonic Industries Limited

240 Traders Boulevard, Mississauga, Ontario L4Z 1W7
Tel: (905) 890-2113 Fax: (905) 890-5338
www.til.ca

REVISION HISTORY
[13RE480]

REV	SECTION - PAGE -	DESCRIPTION	DATE	Edited by
N/C		Original document release	MAY 2013	
Issue1	Summary of DO-160G Env.Testing	Update Temp & Alt category in DO-160G chart, fix typo in STC Approval Note from "DO-160F" to "DO-160G".	OCT 2013	H.Duff

INFORMATION NOTES

ESD CAUTION



This unit contains static sensitive devices. Wear a grounded wrist strap and/or conductive gloves when handling printed circuit boards.

FCC COMPLIANCE INFORMATION

This device complies with Part 15 of the FCC Rules. Operation is subject to the following two conditions: (1) this device may not cause harmful interference and (2) this device must accept any interference received, including interference that may cause undesired operation.

WARNING AND DISCLAIMER

Changes or modifications not expressly approved by Technisonic Industries could void the user's authority to operate the equipment.

This manual is designed to provide information about the RC-9000. Every effort has been made to make this manual as complete and accurate as possible.

WARRANTY INFORMATION

The Model RC-9000 Remote Control Head is under warranty for one year from date of purchase. Failed units caused by defective parts, or workmanship should be returned to:

Technisonic Industries Limited
240 Traders Boulevard
Mississauga, Ontario L4Z 1W7

Tel: (905) 890-2113
Fax: (905) 890-5338

SUMMARY OF DO-160G ENVIRONMENTAL TESTING

Summary of DO-160G Environmental Testing for Technisonic Model RC-9000 Remote Control:

Conditions	Category
Temperature and Altitude	A2, B1, C4, D1
Temperature Variation	B
Humidity	A
Operational shock and Crash Safety	A
Vibration	S, U
Magnetic Effect	Z
Power Input	B
Voltage Spike	B
Audio Frequency Susceptibility	B
Induced Signal Susceptibility	AC
Radio Frequency Susceptibility	T
Radio Frequency Emission	M
Electrostatic Discharge	A

STC APPROVAL NOTE

Presently, no TSO standard exists for airborne FM transceivers or their remote controllers. To make it easier for installation agencies to provide their customers with an approved installation supported by an effective Airworthiness Approval, Technisonic has secured Supplemental Type Certificate (STC) Approvals (both US and Canadian) on its Airborne FM products for many helicopters currently being delivered in the US and Canada as well as a number of single engine fixed wing aircraft. The above referenced DO-160G test data is also on file and available from Technisonic to support approval requirements in airframes for which Technisonic does not possess an STC.

Approved aircraft types are listed in the attachments to the formal STC documents. These STCs are the exclusive property of Technisonic and require the written authority of Technisonic for their use. To assist Factory Authorized Technisonic Dealers in the certification process, we have placed copies of our Canadian and US STCs on our web site along with a letter of authorization for their use. These documents may be downloaded and used as support for the technical submission to FAA or Transport Canada. Only authorized factory dealers/installers are permitted to download and make use of these documents on behalf of their customers (end users) in support of regulatory agency approval. Please refer to the Technisonic web site www.til.ca for the latest issue of available STCs and letter of authorization for use.

**TABLE OF
CONTENTS**

SECTION	TITLE	PAGE
SECTION 1 GENERAL DESCRIPTION		
1.1	INTRODUCTION	1-1
1.2	DESCRIPTION	1-1
1.3	TECHNICAL CHARACTERISTICS	1-1
SECTION 2 INSTALLATION INSTRUCTIONS		
2.1	GENERAL	2-1
2.2	EQUIPMENT PACKING LOG	2-1
2.3	RC-9000 INSTALLATION	2-1
2.4	INSTALLATION KIT - CONTENTS	2-1
2.5	PIN LOCATIONS AND CONNECTIONS	2-2
2.6	WIRING INSTRUCTIONS	2-2
2.7	POST INSTALLATION EMI TEST	2-5

LIST OF FIGURES

FIGURE	TITLE	PAGE
2.1	Outline Drawing	2-1
2.2	Wiring Connections and Notes	2-3

LIST OF TABLES

TABLE	TITLE	PAGE
2.1	9-Pin D-Connections (J1)	2-2

SECTION 1 - GENERAL DESCRIPTION

1.1 INTRODUCTION

This publication provides installation information on the RC-9000 remote control.

1.2 DESCRIPTION

The RC-9000 is designed to be a remote control head for the TDFM-9000 series of airborne transceivers. It is a secondary (slave) control point and is not intended to replace the function of the front panel of the radio.

1.3 TECHNICAL CHARACTERISTICS

<u>Specification</u>	<u>Characteristic</u>
Model Designation:	RC-9000
Physical Dimensions:	Approx. 5.75"x 4.5" x 1.3"
Weight:	16oz (455g)
Operating Temperature Range:	45°C to +60° C
Power Requirement:	
Voltage:	28.0 Vdc, ± 15%
Current:	60mA minimum 100mA maximum
Communication Protocol:	RS-232 115200,N,8,1
Panel Back Lighting:	28 VDC or 5VAC (software configurable)

This page left intentionally blank

SECTION 2 – INSTALLATION INSTRUCTIONS

2.1 GENERAL

This section contains information and instructions for the correct installation of the RC-9000 remote control.

2.2 EQUIPMENT PACKING LOG

Unpack the equipment and check for any damage that may have occurred during transit. Save the original shipping container for returns due to damage or warranty claims. Check that each item on the packing slip has been shipped in the container.

2.3 INSTALLATION

The RC-9000 Remote Control is designed to be Dzus mounted and should be installed in conjunction with an IN-RC7 installation kit. See figure 2-1 for an outline drawing of the unit with dimensions to facilitate the installation.

2.4 INSTALLATION KIT - CONTENTS

The IN-RC7 installation kit (P/N 059616-1) consists of:

1. One 9-pin Cannon D mating connector (female) complete with crimp pins and hood.

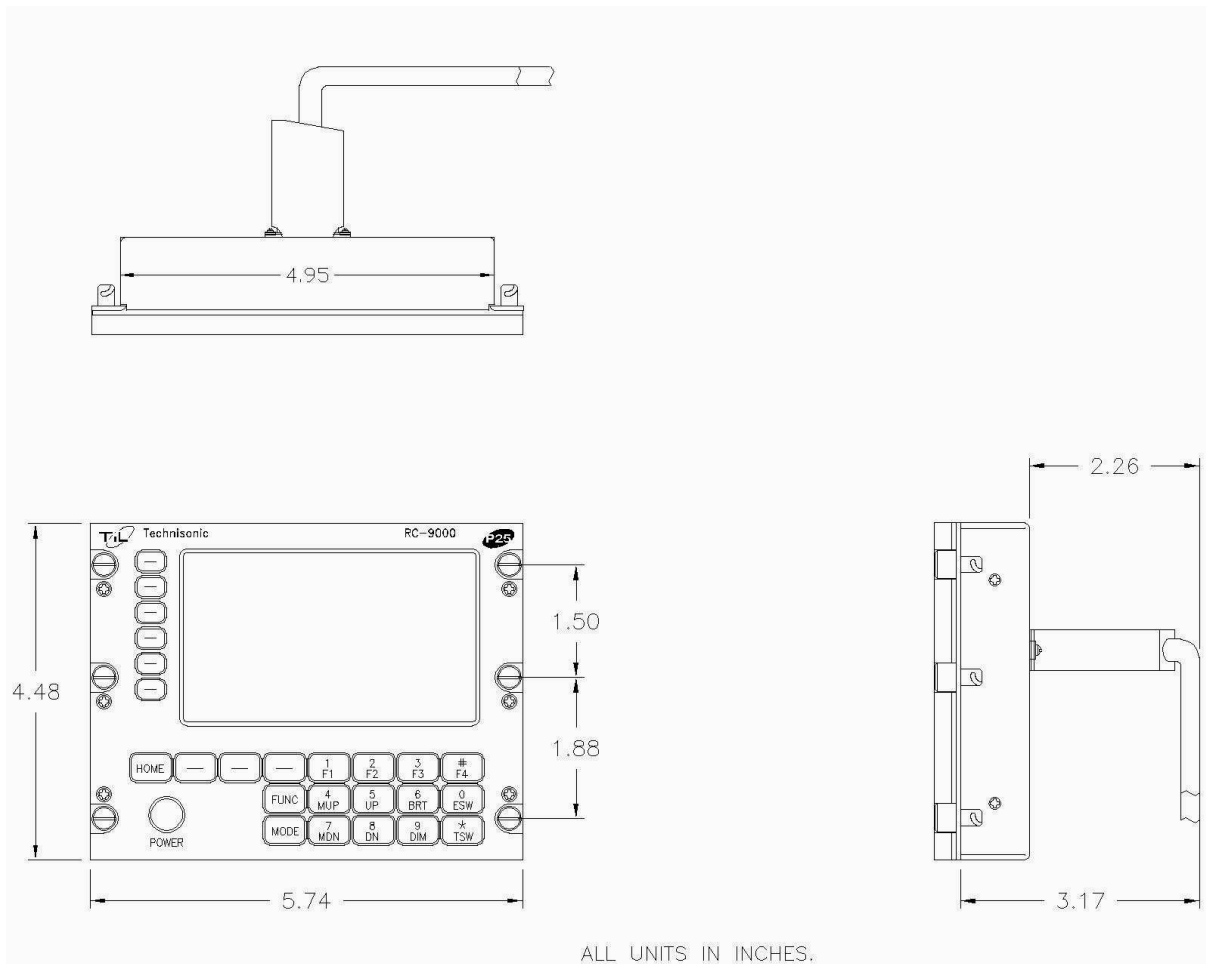

FIGURE 2.1 Outline Drawing for Model RC-9000

2.5 INSTALLATION - PIN LOCATIONS AND CONNECTIONS

J1 (9-Pin D-Connections) - Use FEMALE Connector	
Pin #	Description
1	Ground
2	n/c
3	n/c
4	+28 Volts DC
5	n/c
6	Backlight
7	RX Data
8	TX Data
9	n/c

TABLE 2.1 Wire connections

2.6 INSTALLATION - WIRING INSTRUCTIONS

Figure 2.2 shows all required connections and recommended wire sizes for the RC-9000 Remote Control.

2.6.1 MAIN GROUND – PIN 1, J1

Pin 1 should be connected to ground. The pin is internally connected to the chassis.

2.6.2 N/C - PIN 2, J1

No connect.

2.6.3 N/C - PIN 3, J1

No connect.

2.6.4 +28 VOLTS DC - PIN 4, J1

Connect to the 28 volt DC avionics bus through a 1 amp breaker.

2.6.5 N/C - PIN 5, J1

No connect.

2.6.6 BACKLIGHT - PIN 6, J1

Connect to the aircraft dimmer bus. Backlighting is 28 volts DC or 5 volts AC.

2.6.7 TX AND RX DATA - PINS 7 AND 8, J1

These pins are to be connected to the RS-232 pins on the TDFM-9000. TX data connects to RX data on the radio and RX data from the remote goes to TX data on the radio.

2.6.8 N/C - PIN 9, J1

No connect.

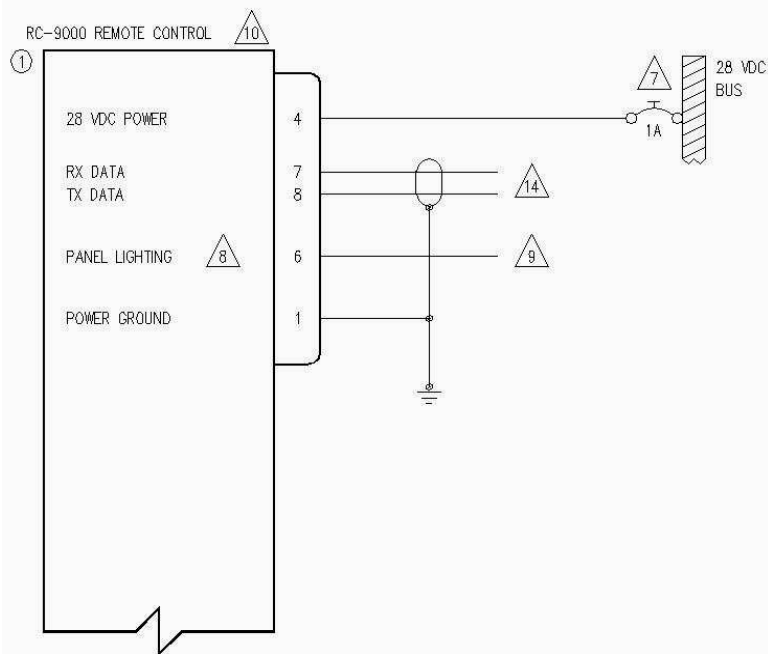

QTY	ITEM	PART NUMBER	DESCRIPTION	SPEC	MATERIAL
1	1	RC-9000	REMOTE CONTROL HEAD	TECHNISONIC INDUSTRIES LIMITED	
1	2	7274-11-1	CIRCUIT BREAKER, 1 AMP	KLIXON	

NOTES:

- 1) ALL WIRE IAW MIL-W-22759 UNLESS OTHERWISE SPECIFIED.
- 2) ALL CABLE IAW MIL-C-27500 UNLESS OTHERWISE SPECIFIED.
- 3) COAXIAL CABLE IAW MIL-C-17 UNLESS OTHERWISE SPECIFIED. DO NOT USE COAX WITH PVC INSULATION.
- 4) FABRICATION & INSTALLATION OF WIRING HARNESS IAW AC 43.13-1B CHAPTER 11.
- 5) GROUNDING AND BONDING IAW AC 43.13-1B CHAPTER 11, SECTION 15.
- 6) ALL WIRE TO BE #22 AWG MINIMUM, UNLESS OTHERWISE SPECIFIED.



AN EQUIVALENT CIRCUIT BREAKER OR FUSE MAY BE USED.



THE RC-9000 BACK LIGHTING CIRCUIT CAN OPERATE FROM 5VAC OR 24VDC. MAKE SURE THE PROPER VOLTAGE IS SELECTED IN THE CONFIGURATION MENU.



CONNECT TO THE APPROPRIATE AIRCRAFT DIMMING BUSS.



INSTALLATION OF TRANSCEIVER IAW AC 43.13-1B CHAPTER 4, SECTION 4 AND AC 43.13-2A, CHAPTER 2. PR3 1/2 DZUS RAIL OR EQUIVALENT MAY BE USED.

- 11) TEST THE SYSTEM IN ACCORDANCE WITH THE POST-INSTALLATION TEST PROCEDURE IN THE INSTALLATION AND OPERATING INSTRUCTIONS MANUAL.
- 12) REFER TO THE AIRCRAFT STRUCTURAL REPAIR MANUAL AND THE MAINTENANCE MANUAL FOR INSTRUCTIONS AND INFORMATION PERTINENT TO THIS INSTALLATION.
- 13) THE USE OF RED DISPLAYS SHOULD BE MINIMIZED OR AVOIDED SO AS NOT TO DETRACT FROM THE ATTENTION GETTING CHARACTERISTICS NEEDED IN WARNING AND CAUTION ANNUNCIATORS. RED SHOULD BE USED TO ANNUNCIATE EMERGENCY CONDITIONS REQUIRING IMMEDIATE RESPONSE BY THE FLIGHT CREW. UNITS WITH RED DISPLAYS SHOULD NOT BE LOCATED IN CLOSE PROXIMITY TO WARNING AND CAUTION ANNUNCIATORS. THE INSTALLATION OF UNITS WITH RED DISPLAYS MUST BE EVALUATED ON A CASE BY CASE BASIS TO ENSURE THAT THE EFFECTIVENESS OF THE WARNING AND CAUTION ANNUNCIATORS IS NOT ADVERSELY AFFECTED.



TO BE CONNECTED TO THE RS-232 PORT ON THE TDFM-9000 TRANSCEIVER.

FIGURE 2.2 Wiring connections and notes for the RC-9000.

APPENDIX TO INSTALLATION INSTRUCTIONS

2.7 APPENDIX TO INSTALLATION INSTRUCTIONS POST INSTALLATION EMI TEST

2.7.1 PURPOSE

The purpose of this test is to identify any interference that the RC-9000 remote control head may cause with existing aircraft systems.

2.7.2 TEST CONDITIONS

The RC-9000 should be installed and function tested. The TDFM-9000 transceiver should be on throughout this test.

2.7.3 METHODOLOGY

Most of the EMI tests can be accomplished on the ground.

The GPS should be operational and navigating with at least the minimum compliment of satellites. The VHF comm should have the squelch open. VOR/DME receivers should be selected for display. If possible, set up a DME/Transponder ramp test set and adjust the output until the flags are out of view. The transponder and encoder should be monitored with ramp test equipment. Set the output of the transponder test set to 3db above the output necessary to achieve 90% reply. If possible set the ADF to a nearby navigation station.

Switch the RC-9000 on and off as often as required.

Observe the GPS for any degradation in satellite status or availability or flags. Listen for any noise or detected audio signals on the VHF comm(s). Listen for any noise or detected audio signals on the VOR/LOC receiver audio; look for any moment of flags or needles on the VOR/LOC/GS navigation display(s).

List the power plant, fuel and other electric instruments not already in the chart provided and note any anomalies that occur due to operation of the RC-9000. Assess the results.

If the aircraft is equipped with an autopilot or a stability augmentation system, then test fly the aircraft and verify that operation of the RC-9000 does not have adverse effects on these systems. After checking for gross effects at a safe altitude, fly a coupled ILS approach and look for any anomalies.

2.7.4 RESULTS

If the installed system passes all of the applicable EMI tests, then no further action is required. If interference is observed then the interference must be assessed against the appropriate standards of airworthiness for the system in question. A complete discussion of all the standards of airworthiness to be applied in assessing EMI effects is beyond the scope of this document.

2.7.5 PROCEDURE

List the power plant, fuel and other electric instruments not already included in the chart below and note any anomalies that occur due to operation of the RC-9000. Assess the results.

STEP	SYSTEM	PASS	FAIL	NOTES
1	Com 1&2			
2	Transponder & Encoder			
3	ADF 1 & 2			
4	VG			
5	Glideslope 1&2			
6	VOR/LOC 1&2			
7	Compass			
8	Directional Gyro			
9	Fuel Pressure			
10	Oil Temp			
11	Amps			
12	Bus Voltage			

13	Fuel %			
14	Ng			
15	TOT			
16	Torque %			
17	Enunciators			
18	Digital Clock			
19	Oil Pressure			
20	DME 1&2			
21	GPS			
22	Autopilot			
23	Stability Augmentation Systems			
24	Coupled ILS Approach			

NOTES:

Technisonic Industries Limited

240 Traders Blvd., Mississauga, ON Canada L4Z 1W7

Tel: (905) 890-2113 Fax: (905) 890-5338

**IMPORTANT
WARRANTY**

All communication equipment manufactured by Technisonic Industries Limited is warranted to be free of defects in Material or Workmanship under normal use for a period of one year from Date of Purchase by the end user.

Warranty will only apply to equipment installed by a factory approved and/or authorized facility in accordance with Technisonic published installation instructions. Equipment falling under the following is not covered by warranty:

- equipment that has been repaired or altered in any way as to affect performance,
- equipment that has been subject to improper installation,
- equipment that has been used for purposes other than intended,
- equipment that has been involved in any accident, fire, flood, immersion or subject to any other abuse.

Expressly excluded from this warranty are changes or charges relating to the removal and re-installation of equipment from the aircraft. Technisonic will repair or replace (at Technisonic's discretion) any defective transceiver (or part thereof) found to be faulty during the Warranty Period.

Faulty equipment must be returned to Technisonic (or its authorized Warranty Depot) with transportation charges prepaid. Repaired (or replacement) equipment will be returned to the customer with collect freight charges. If the failure of a transceiver occurs within the first 30 days of service, Technisonic will return the repaired or replacement equipment prepaid.

Technisonic reserves the right to make changes in design, or additions to, or improvements in its products without obligation to install such additions and improvements in equipment previously manufactured. This Warranty is in lieu of any and all other warranties express or implied, including any warranty of merchantability or fitness, and of all other obligations or liabilities on the part of Technisonic.

This Warranty shall not be transferable or assignable to any other persons, firms or corporations.

**For warranty registration please complete the on-line
Warranty Registration Form found at www.til.ca.**



RC-9000

MULTIBAND P25 AIRBORNE TRANSCEIVER REMOTE CONTROL



Operating Instructions

TiL Document No. 13RE481
Rev. B

JANUARY 2014

Technisonic Industries Limited

240 Traders Boulevard, Mississauga, Ontario L4Z 1W7
Tel: (905) 890-2113 Fax: (905) 890-5338
www.til.ca

Copyright by Technisonic Industries Limited. All rights reserved.

REVISION HISTORY
[13RE481]

REV	SECTION - PAGE -	DESCRIPTION	DATE	EDITED BY
N/C		Original Document Release.	MAY 2013	
A	ii	Updated Summary of DO-160G Env. Testing Temperature & Altitude category. Fixed typo in STC Approval Note from "DO-160F" to "DO-160G."	OCT 2013	H.Duff
B	2-1 2-3 All	Updated Figure 2.1: Corrected Arrows and Yellow & Blue Bands (which were reversed). 2.6: Corrected Yellow & Blue Bands. Corrected Spelling & Grammar throughout document.	JAN. 14, 2014	A.L.

INFORMATION NOTES

ESD CAUTION



This unit contains static sensitive devices. Wear a grounded wrist strap and/or conductive gloves when handling printed circuit boards.

FCC COMPLIANCE INFORMATION

This device complies with Part 15 of the FCC Rules. Operation is subject to the following two conditions: (1) this device may not cause harmful interference and (2) this device must accept any interference received, including interference that may cause undesired operation.

WARNING AND DISCLAIMER

Changes or modifications not expressly approved by Technisonic Industries could void the user's authority to operate the equipment.

This manual is designed to provide information about the RC-9000. Every effort has been made to make this manual as complete and accurate as possible.

WARRANTY INFORMATION

The Model RC-9000 Remote Control Head is under warranty for one year from date of purchase. Failed units caused by defective parts or workmanship should be returned to:

Technisonic Industries Limited
240 Traders Boulevard
Mississauga, Ontario L4Z 1W7

Tel: (905) 890-2113
Fax: (905) 890-5338

SUMMARY OF DO-160G ENVIRONMENTAL TESTING

Summary of DO-160G Environmental Testing for Technisonic Model RC-9000 Remote Control:

Conditions	Category
Temperature and Altitude	A2, B1, C4, D1
Temperature Variation	B
Humidity	A
Operational shock and Crash Safety	A
Vibration	S, U
Magnetic Effect	Z
Power Input	B
Voltage Spike	B
Audio Frequency Susceptibility	B
Induced Signal Susceptibility	AC
Radio Frequency Susceptibility	T
Radio Frequency Emission	M
Electrostatic Discharge	A

STC APPROVAL NOTE

Presently, no TSO standard exists for airborne FM transceivers or their remote controllers. To make it easier for installation agencies to provide their customers with an approved installation supported by an effective Airworthiness Approval, Technisonic has secured Supplemental Type Certificate (STC) Approvals (both US and Canadian) on its Airborne FM products for many helicopters currently being delivered in the US and Canada as well as a number of single engine fixed wing aircraft. The above referenced DO-160G test data is also on file and available from Technisonic to support approval requirements in airframes for which Technisonic does not possess an STC.

Approved aircraft types are listed in the attachments to the formal STC documents. These STCs are the exclusive property of Technisonic and require the written authority of Technisonic for their use. To assist Factory Authorized Technisonic Dealers in the certification process, we have placed copies of our Canadian and US STCs on our website along with a letter of authorization for their use. These documents may be downloaded and used as support for the technical submission to FAA or Transport Canada. Only authorized factory dealers/installers are permitted to download and make use of these documents on behalf of their customers (end users) in support of regulatory agency approval. Please refer to the Technisonic website www.til.ca for the latest issue of available STCs and letter of authorization for use.

TABLE OF CONTENTS

SECTION	TITLE	PAGE
SECTION 1 GENERAL DESCRIPTION		
1.1	INTRODUCTION	1-1
1.2	DESCRIPTION	1-1
1.3	TECHNICAL CHARACTERISTICS	1-1
SECTION 2 OPERATING INSTRUCTIONS		
2.1	GENERAL	2-1
2.2	FRONT PANEL	2-1
2.3	POWER	2-1
2.4	KNOB	2-2
2.5	SOFT KEYS AND HOME	2-2
2.6	BAND KEYS	2-3
2.7	FUNC KEY	2-3
2.8	F1 to F4 KEYS	2-3
2.9	MUP(4) AND MDN(7) KEYS (Memory Up and Down Keys)	2-3
2.10	UP(5) AND DOWN(8) KEYS	2-3
2.11	BRT(6) AND DIM(9) KEYS	2-3
2.12	ESW(0) KEY (Ergo Switch Key)	2-4
2.13	TSW(*) KEY (Toggle Switch Key)	2-4
2.14	DISPLAY	2-4
2.15	GENERAL OPERATION	2-4

LIST OF FIGURES

FIGURE	TITLE	PAGE
2.1	Front Panel Controls – RC-9000 Remote Control.....	2-1

SECTION 1 - GENERAL DESCRIPTION

1.1 INTRODUCTION

This publication provides operating and installation information on the RC-9000 remote control.

1.2 DESCRIPTION

The RC-9000 is designed to be a remote control head for the TDFM-9000 series of airborne transceivers. It is a secondary (slave) control point and is not intended to replace the function of the front panel of the radio.

1.3 TECHNICAL CHARACTERISTICS

<u>Specification</u>	<u>Characteristic</u>
Model Designation:	RC-9000
Physical Dimensions:	Approx. 5.75"x 4.5" x 1.3"
Weight:	16oz (455g)
Operating Temperature Range:	45° C to +60° C
Power Requirement:	
Voltage:	28.0 VDC, ± 15%
Current:	60 mA minimum 100 mA maximum
Communication Protocol:	RS-232 115200,N,8,1
Panel Back Lighting:	28 VDC or 5VAC (Software configurable)

This page left intentionally blank

SECTION 2 – OPERATING INSTRUCTIONS

2.1 GENERAL

The RC-9000 is designed to be a secondary control point for the TDFM-9000 airborne transceiver. These instructions assume a working knowledge of the TDFM-9000 transceiver. Operation of the RC-9000 is similar to the TDFM-9000.

2.2 FRONT PANEL

Refer to the diagrams below:

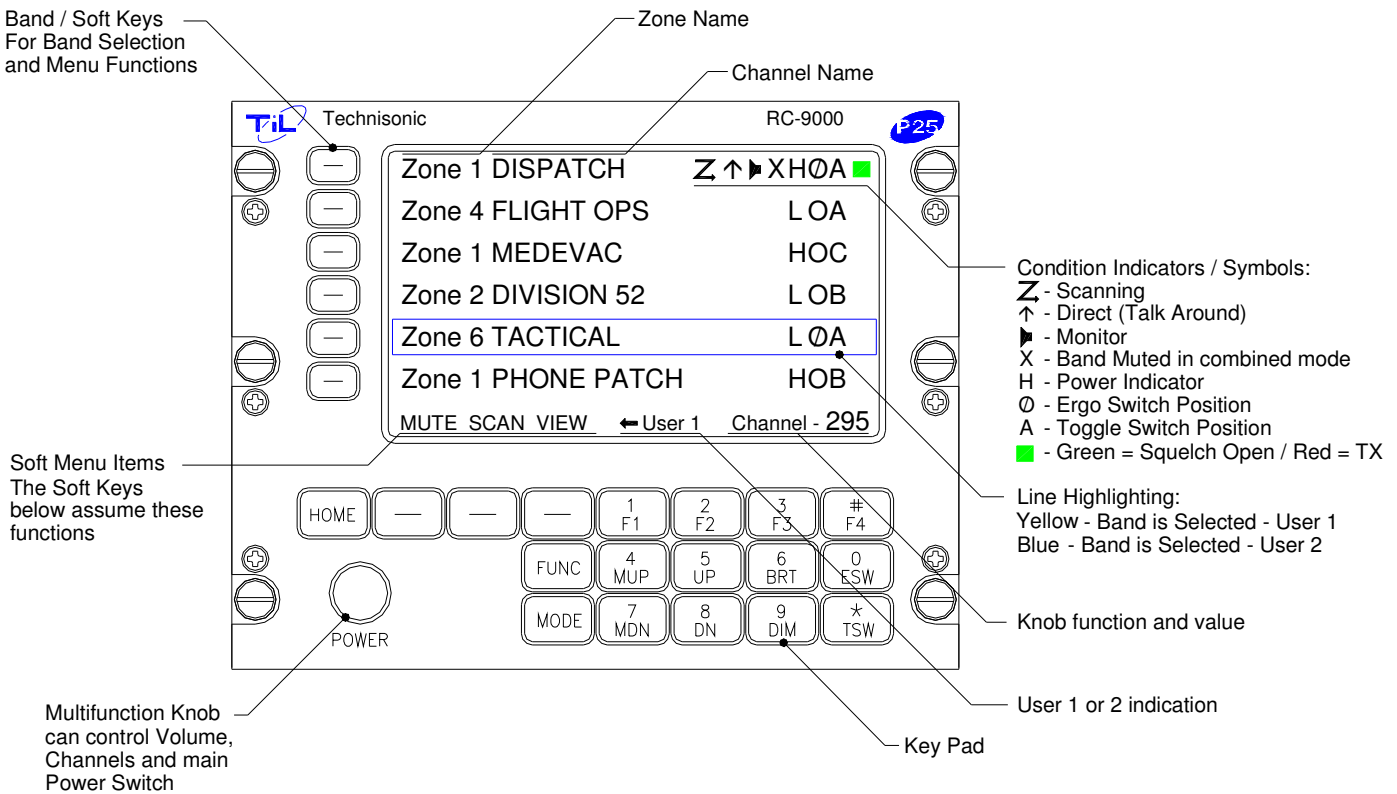

FIGURE 2.1 Front Panel Controls – RC-9000 Remote Control

2.3 POWER

To switch the unit on, momentarily press the knob until the radio powers up. The display will show the “TiL” logo and the software version installed. The model number along with which RF modules are installed will follow this. The display will then show the normal display. To switch off the transceiver at any time, press and hold the knob for 2 seconds until the display shows OFF and then release. If it is desired to have the RC unit power up with the radio master in the aircraft, an ‘always on’ mode can be set by placing a shorting jumper on J2 on the interface board inside the unit.

2.4 KNOB

The knob is a rotary encoder, which turns endlessly. The knob also has a push button incorporated in it so you can press the knob as well as turn it. The knob will default to control the volume. Pressing the knob again will change its function to act as the channel selector. Another knob press will bring you to the recall mode. In the recall mode, typing in the channel number will bring you quickly to that channel without scrolling through many channels. Pressing the knob again brings it back to the volume control mode. The current function of the knob is shown at the bottom right of the display.

2.5 SOFT KEYS AND HOME

The RC unit has nine soft keys. The 3 soft keys below the display assume the function shown on the menu above them. The functions displayed depend on how the module was programmed with the customer programming software (APX CPS)[™]. These menu items can be different on a channel by channel basis. Typical menu items may include:

- ZONE** - Pressing this function will prompt you for a new zone number which can be entered directly (if the keypad is in NUM LOCK mode) or scrolled using the UP(5) and DN(8) keys.
- MUTE** - Selecting this function will prompt you for an on or off entry using the soft keys to mute the tones. Tones refer to the beeps heard when pressing buttons.
- PWR** - Selecting PWR will allow the power output of the radio to be set to high or low.
- PROG** - Selecting PROG brings you to user programmable features of the radio such as telephone numbers or scan lists. The ability for the user to program phone numbers, scan lists, etc. can be enabled or disabled by the CPS[™].
- VIEW** - The view function is used to view lists. Lists can include scan lists, phone numbers, call lists, and/or paging.
- FPP** - Front Panel Programming mode allows you to program at the front panel without the customer programming software. This option is available on all standard modules.

At any time while in one of these functions, you can escape back to the normal mode by pressing the HOME key. When programming the modules with the CPS[™], it is suggested not to double up functions. For example, programming a soft key to CHAN would be redundant since there is already a channel function using the knob.

The six soft keys to the left of the display are used to select the active band for which the knob and keyboard will control. If the radio is connected using the one or both of the combined inputs, the selected band will also be selected for transmit. If you press a key on a band that is already selected, the receive audio will be toggled off and on. This can be useful to temporarily mute distracting traffic.

2.6 MODE KEY

This button selects USER 1 or USER 2 mode when the unit is installed with both combined input/outputs connected. USER 1 or 2 will be indicated at the bottom of the display, and the selected band box will show yellow for USER 1 and blue for USER 2.

2.7 FUNC KEY

Pressing the FUNC key will bring up the first functions menu. Consult the TDFM-9000 Operating Instructions for further details.

2.8 F1 to F4 KEYS

Four function keys at the top of the keypad (when not programmed for quick channels as mentioned above) provide the same actions as the three side buttons and the top button found on the APX-7000 portable. They are as follows:

- F1 – Top-side-button (purple button) on the portable.
- F2 – Centre-side-button (with one dot) on the portable.
- F3 – Bottom-side button (with two dots) on the portable.
- F4 – Top button (orange button) on the portable.

Consult the TDFM-9000 Operating Instructions for further details.

2.9 MUP(4) AND MDN(7) KEYS (Memory Up and Down Keys)

These keys provide the same function as the rotary knob does when it is set to CHAN. These keys can be used to scroll through the channels. A single press will step the channel by one, but a push and hold will scroll to a desired channel number. The function of the rotary knob is automatically set to CHAN when either of these keys is pressed.

2.10 UP(5) AND DN(8) KEYS

The keys provide the same function as the left and right arrow keys on the portable. The UP key equates to the right arrow key and the DN is the left. These keys are used for a variety of functions but in the normal operating mode, they are used to scroll through the soft key menus.

2.11 BRT(6) AND DIM(9) KEYS

Use these keys to dim or brighten the display. The radio powers up at full brightness for normal use but can be dimmed for night operations.

2.12 ESW(0) KEY (Ergo Switch Key)

The ESW key provides the function of the concentric or 'ergo' switch on the portable. The switch has two conditions which are represented by 'O' and 'Ø'. Pressing the ESW key toggles the condition back and forth. The condition is displayed at the right hand side of the display line (second character from the right). The ergo switch condition is saved when the unit is turned off. There are separate conditions for each band installed. The ESW key can be programmed with the CPS™ to a variety of functions such as low power, scan and secure, or encrypted mode.

2.13 TSW(*) KEY (Toggle Switch Key)

The TSW key provides the function of the toggle switch on the portable. The switch has three conditions which are represented by 'A', 'B', and 'C'. Pressing the TSW key toggles the condition A,B,C,A,B, etc. The condition is displayed at the far right hand side of the display line (last character on the right). The toggle switch condition is saved when the unit is turned off. There are separate conditions for each band installed. The TSW key can be programmed with the APX CPS™ to a variety of functions such as low power, scan, zone select, or pl disabled mode.

2.14 DISPLAY

The transceiver has full colour LCD display. The zone name, channel name, condition symbols (scan, direct, call, secure, monitor, etc.), and switch settings will be displayed for each module. The active band as selected by the soft keys will be highlighted. The bottom line displays the menu items associated with the module selected and the mode of the knob.

2.15 GENERAL OPERATION

Switch on the RC unit by momentarily pressing the knob. Select the desired band by pressing one of the band select keys on the left of the display. Press the knob again to show CHAN on the bottom right of the display. Rotate the knob until the desired channel or talk group is selected. Press the knob until VOL is again shown on the display. You can adjust the volume by waiting until a signal is received or by pressing F1 (factory programmed for monitor function) and adjusting the rotary knob. The radio is ready to use. If the radio is installed in separate mode, remember that the band selected by the soft keys is what menu is displayed on the screen but the band selected by the audio panel is the band that you are transmitting and receiving on. To use the DTMF keypad while transmitting, the band you are using must be selected on the display. If the radio is installed using both of the combined input/outputs, then pressing the MODE key will alternate the display between the two users.

Technisonic Industries Limited

240 Traders Blvd., Mississauga, ON Canada L4Z 1W7
Tel: (905) 890-2113 Fax: (905) 890-5338

**IMPORTANT
WARRANTY**

All communication equipment manufactured by Technisonic Industries Limited is warranted to be free of defects in Material or Workmanship under normal use for a period of one year from Date of Purchase by the end user.

Warranty will only apply to equipment installed by a factory approved and/or authorized facility in accordance with Technisonic published installation instructions. Equipment falling under the following is not covered by warranty:

- Equipment that has been repaired or altered in any way as to affect performance,
- Equipment that has been subject to improper installation,
- Equipment that has been used for purposes other than intended,
- Equipment that has been involved in any accident, fire, flood, immersion, or subject to any other abuse.

Expressly excluded from this warranty are changes or charges relating to the removal and re-installation of equipment from the aircraft. Technisonic will repair or replace (at Technisonic's discretion) any defective transceiver (or part thereof) found to be faulty during the Warranty Period.

Faulty equipment must be returned to Technisonic (or its authorized Warranty Depot) with transportation charges prepaid. Repaired (or replacement) equipment will be returned to the customer with collect freight charges. If the failure of a transceiver occurs within the first 30 days of service, Technisonic will return the repaired or replacement equipment prepaid.

Technisonic reserves the right to make changes in design, or additions to, or improvements in its products without obligation to install such additions and improvements in equipment previously manufactured. This Warranty is in lieu of any and all other warranties express or implied, including any warranty of merchantability or fitness, and of all other obligations or liabilities on the part of Technisonic.

This Warranty shall not be transferable or assignable to any other persons, firms, or corporations.

**For warranty registration, please complete the on-line
Warranty Registration Form found at www.til.ca.**