



TFM-566

VHF/VHF LO FM AIRBORNE TRANSCEIVER

(P/Ns 031217-1,3)



Installation and Operating Instructions

TiL Document No. 03RE318
Revision B Issue 1

SEPTEMBER 2003

Technisonic Industries Limited

240 Traders Boulevard, Mississauga, Ontario L4Z 1W7
Tel: (905) 890-2113 Fax: (905) 890-5338
www.til.ca

REVISION HISTORY

[03RE318]

REV	SECTION - PAGE -	DESCRIPTION	DATE	EDITED BY
n/c REV A REV B		Original Document	MAR 2003 JUL 2003 SEP 2003	
Rev B issue 1	Global 3-4,3-5	New document template, Title page changed, Added Headers/Footers, Rev page, Warranty pg Split Fig 3.2 to make it bigger, easier to read.	APR 2012	FM

CAUTION ! STATIC SENSITIVE !



This unit contains static sensitive devices. Wear a grounded wrist strap and/or conductive gloves when handling printed circuit boards.

FCC COMPLIANCE INFORMATION

This equipment has been tested and found to comply with the limits for a Class A digital device, pursuant to Part 15 of the FCC Rules. These limits are designed to provide reasonable protection against harmful interference when the equipment is operated in a commercial environment. This equipment generates, uses, and can radiate radio frequency energy and, if not installed and used in accordance with the instruction manual, may cause harmful interference to radio communications. Operation of this equipment in a residential area is likely to cause harmful interference in which case the user will be required to correct the interference at his own expense.

WARNING

Changes or modifications not expressly approved by Technisonic Industries could void the user's authority to operate the equipment.

WARRANTY INFORMATION

The Model TFM-566, Transceiver is under warranty for one year from date of purchase. Failed units caused by defective parts, or workmanship should be returned to:

Technisonic Industries Limited
240 Traders Boulevard
Mississauga, Ontario L4Z 1W7

Tel: (905) 890-2113
Fax: (905) 890-5338

Summary of DO-160C Environmental Testing

Summary of DO-160C Environmental Testing for Technisonic Model TFM-566, VHF and VHF Low Transceiver:

Conditions	Section	Description of Conducted Tests
Temperature and Altitude	4.0	Equipment tested to categories B2 and D1.
Vibration	8.0	Equipment is tested without shock mounts to categories B, M and N.
Magnetic Effect	15.0	Equipment is class A.
Power Input	16.0	Equipment tested to category B.
Voltage Spike	17.0	Equipment tested to category B.
RF Emission	21.0	Equipment tested to category Z.

Installation Approval Note

Presently no TSO standard exists for airborne FM transceivers. To make it easier for installation agencies to provide their customers with an approved installation supported by an effective Airworthiness Approval, Technisonic has secured Supplemental Type Certificate (STC) Approvals (both US and Canadian) on its Airborne FM products for many helicopters currently being delivered in the US and Canada as well as a number of single engine fixed wing aircraft. The above referenced DO-160C test data is also on file and available from Technisonic to support approval requirements in airframes for which Technisonic does not possess an STC.

Approved aircraft types are listed in the attachments to the formal STC documents. These STCs are the exclusive property of Technisonic and require the written authority of Technisonic for their use. To assist Factory Authorized Technisonic Dealers in the certification process, we have placed copies of our Canadian and US STCs on our web site along with a letter of authorization for their use. These documents may be downloaded and used as support for the technical submission to FAA or Transport Canada. Only factory authorized dealers/installers are permitted to download and make use of these documents on behalf of their customers (end users) in support of regulatory agency approval. Please refer to the Technisonic web site www.til.ca for the latest issue of available STCs and letter of authorization for use.

TABLE OF CONTENTS

SECTION	TITLE	PAGE
SECTION 1 GENERAL DESCRIPTION		
1.1	INTRODUCTION	1-1
1.2	DESCRIPTION	1-1
1.3	PURPOSE OF EQUIPMENT	1-1
1.4	MODEL VARIATION	1-1
1.5	TECHNICAL CHARACTERISTICS	1-2
SECTION 2 OPERATING INSTRUCTIONS		
2.1	FEATURES.....	2-1
2.2	OPERATING INSTRUCTIONS	2-3
2.3	PROGRAMMING INSTRUCTIONS	2-4
2.4	PRIORITY AND SELECTIVE MEMORY CHANNEL SCANNING	2-5
2.5	SCANNING FUNCTION	2-5
2.6	DIRECT FREQUENCY ENTRY MODE	2-6
2.7	RECEIVE FREQUENCY SIMPLEX FUNCTION	2-6
2.8	KEYBOARD LOCKOUT FUNCTION	2-6
2.9	VARIABLE FREQUENCY MODE FUNCTION	2-6
2.10	LED DISPLAY VARIABLE DIMMING MODE	2-6
2.11	90 SECOND TRANSMITTER TIMEOUT FEATURE	2-7
2.12	QUICK GUARD PROGRAMMING FEATURE	2-7
2.13	PROGRAMMING CTCSS TONES	2-7
2.14	PC MEMORY/PROGRAMMING DOWNLOAD CAPABILITY	2-9
SECTION 3 INSTALLATION INSTRUCTIONS		
3.1	GENERAL	3-1
3.2	EQUIPMENT PACKING LOG	3-1
3.3	TRANSCEIVER INSTALLATION	3-1
3.4	INSTALLATION KIT - CONTENTS	3-1
3.5	ANTENNA INSTALLATION	3-1
3.6	INSTALLATION - PIN LOCATIONS AND CONNECTIONS	3-1
3.7	WIRING INSTRUCTIONS	3-6
3.7.1	Main Power +28VDC	3-6
3.7.2	Main Ground	3-6
3.7.3	PTT (Ground Keying)	3-6
3.7.4	Front Panel Back Lighting	3-6
3.7.5	Audio Outputs (600 and 4 Ohms)	3-6
3.7.6	Audio Output Ground	3-6
3.7.7	Mic Signal Input	3-6
3.7.8	Memory Up/Memory Down	3-6
3.7.9	Data Input	3-6
3.8	INTERNAL PROGRAMMING ENABLE/DISABLE JUMPER	3-7
3.9	TRANSMITTER POWER ADJUSTMENTS	3-8

TECHNISONIC INDUSTRIES LIMITED

www.til.ca

3.10	TRANSMITTER MICROPHONE LEVEL ADJUSTMENT	3-8
3.11	MAIN AND GUARD SQUELCH ADJUSTMENT	3-10
3.12	TRANSMITTER DEVIATION ADJUSTMENT	3-10
APPENDIX – POST INSTALLATION EMI TEST		A-1
WARRANTY		

LIST OF FIGURES

FIGURE	TITLE	PAGE
2.1	Operator's Switches and Controls	2-2
2.2	PC Up/Download Cable - Wiring Diagram	2-10
3.0	Transceiver mounted view of 15-pin female and 9-pin male connector	3-1
3.1	Outline Drawing for Model TFM-566 Series Transceivers	3-2
3.2	Wiring connections for the TFM-566 Series Transceivers	3-4
3.3	Internal Enable/Disable Jumper Locations	3-7
3.4	External Adjustment Access Holes	3-9
3.5	VHF Deviation Adjustment Potentiometer Location	3-11
3.6	VLO Deviation Adjustment Potentiometer Location	3-12

LIST OF TABLES

TABLE	TITLE	PAGE
3.1	9-pin D and 15-Pin D Connections	3-3

SECTION 1 - GENERAL DESCRIPTION

1.1 INTRODUCTION

This publication provides operating and installation information on the TFM-566 Transceiver manufactured by Technisonic Industries Limited. The unit offers an extended frequency range with selectable channel spacing and is intended for use (in the U.S.) only by government agencies or contractors thereto, who have obtained licensing for operation in the 138-150 MHz portion of the band. If the TFM-566 transceiver is used in CANADA, VHF operation is restricted to the following sub bands: 138-144, 148-148.99, 149.005-150.005 and 150.05-174 MHz.

1.2 DESCRIPTION

The TFM-566, Transceiver is a frequency agile, fully synthesized airborne transceiver capable of operating in the 138 to 174 MHz and 66 to 88 MHz frequency range in 2.5 kHz increments with either 25 kHz or 12.5 kHz channel spacing. The Transceiver can operate without restriction on any split frequency pair in either band and also incorporates a two channel VHF synthesized guard receiver.

The TFM-566 Transceiver provides 200 operator accessible memory positions per band, each of which is capable of storing a transmit frequency, receive frequency, transmit CTCSS tone or DPL code, receive CTCSS tone or DPL code, an alphanumeric identifier for each channel and wideband (25 kHz) or narrowband (12.5 kHz) channel spacing assignment. Operating frequency and other related data are presented on a 96 character, four line LED matrix display. Data entry and function control are performed via a 12 button keypad. Preset channels may also be scrolled and scanned through keypad function activation. Data may also be entered via a Windows 95/98/NT/2000/ME/XP based computer with the provided software and optional PC Up/download cable, P/N 993390-1.

1.3 PURPOSE OF EQUIPMENT

The TFM-566, VHF/VLO FM Transceiver is designed to provide secondary airborne communications to facilitate operations which are typically performed in a low altitude environment. The transmitter sections of this unit have a minimum of 8 watts and do not exceed 10 watts output power, which may be reduced by a front panel switch to 1 watt, in order to reduce interference to land based systems.

1.4 MODEL VARIATION

There are four variations of the Model TFM-566 Transceiver. All units offer identical features and performance except for the following differences:

TFM-566, P/N 031217-1	GREEN display and 28 Volt back lighting.
TFM-566, P/N 031217-1 (5V)	GREEN display and 28 Volt back lighting.
TFM-566, P/N 031217-3	RED display and 28 Volt back lighting.
TFM-566, P/N 031217-3 (5V)	RED display and 5 Volt back lighting.

Both P/Ns 031217-1 and 031217-3 are always provided with 28 Volt back lighting unless a specific request is made for 5 Volt AC operation.

1.5 TECHNICAL CHARACTERISTICS

<u>Specification</u>	<u>Characteristic</u>
GENERAL	
Model Designation:	TFM-566
Frequency Ranges:	138 to 174 and 66 to 88 MHz
Tuning Increments:	2.5 kHz
Operating Modes:	F3E simplex or semi-duplex
Channel Spacing:	25 or 12.5 kHz
Physical Dimensions (including heatsink):	Approx. 8.0" X 3.0" X 5.75"
Weight:	Approx. 5.1 Lbs (2.3 Kg)
Mounting:	Panel Mount via Dzus fasteners
Operating Temperature Range:	-40°C to +60°C
Power Requirement:	
Voltage:	28.0 Vdc, ± 15%
Current:	Receive - 1.0 A Max. 1 Watt Transmit - 2.0 A Max. 8-10 Watt Transmit - 3.2 A Max. 8-10 Watt Dual Transmit - 5 A Max.
Frequency Selection:	200 memories per band programmed with: a) Tx Frequency/Rx Frequency b) Tx/Rx CTCSS tone or DPL code c) 9 character alpha numeric title
Guard Receiver:	2 channels programmed with: a) Tx Frequency/Rx Frequency b) Tx/Rx CTCSS tone or DPL code c) 9 character alpha numeric title
CTCSS squelch/encoder:	All CTCSS tones available
DPL digital squelch/encoder:	All standard DPL codes
DTMF encoder:	All standard DTMF tones
Audio Outputs:	0.5 Watts into 600 ohms
Speaker Output:	2.5 Watts min. into 4 ohms
Back Lighting:	28 Volts (standard) or 5 Volts (specify)
Display Colour:	Green (standard) or Red (specify)

¹ DPL is a trademark of Motorola Corporation

1.5 TECHNICAL CHARACTERISTICS (continued)

VHF RECEIVER

Sensitivity at 12 dB SINAD	Better than 0.35 μ V
Adjacent Channel Selectivity	-75 dB (25 kHz) -70 dB (12.5 kHz)
Spurious Attenuation	-90 dB
Third Order Intermodulation	-70 dB
Image Attenuation	-80 dB
FM Acceptance	\pm 6 kHz
Hum and Noise	Better than 45 dB
Audio Distortion	less than 5%
Antenna Conducted Emission	less than -70 dBm

VLO (Low Band VHF) RECEIVER

Sensitivity at 12 dB SINAD	Better than 0.35 μ V
Adjacent Channel Selectivity	-70 dB (25 kHz) -60 dB (12.5 kHz)
Spurious Attenuation	-80 dB
Third Order Intermodulation	-70 dB
Image Attenuation	-60 dB
FM Acceptance	\pm 6 kHz
Hum and Noise	Better than 40 dB
Audio Distortion	less than 5%
Antenna Conducted Emission	less than -70 dBm

GUARD RECEIVER

All specifications identical to VHF receiver.

TECHNISONIC INDUSTRIES LIMITED

www.til.ca

1.5 TECHNICAL CHARACTERISTICS (continued)

VHF and VLO TRANSMITTER

RF Power Output	1 watt or 10 watts
Output Impedance	50 ohms
Maximum Deviation (In narrowband mode)	± 5 kHz (25 kHz mode) ± 2.5 kHz (12.5kHz mode)
Spurious Attenuation	-70 dB below carrier level
Frequency Stability	± 2.5 ppm
Microphone Circuit	Carbon or equivalent
Sidetone Output	0.5W (max) into 600 ohms
Harmonic Attenuation	-60 dB below carrier level
FM Hum And Noise	-40 dB
Audio Input	50 mV at 2.5 kHz into 200 ohms input circuit for ± 3.5 kHz deviation, adjust.
FM Audio Distortion	Less than 5%

SECTION 2 – OPERATING INSTRUCTIONS

2.1 FEATURES

The equipment has several important operating features which provide maximum flexibility, performance and versatility. These features include:

1. VHF and VLO bands that can be configured to be operated independently or as a single unit.
2. The unit can be set up as a crossband repeater, linking a VHF and VLO frequency in both directions.
3. 200 memory positions per band which can each be programmed with a transmit and receive frequency with 25 or 12.5 kHz channel spacing, Tx/Rx CTCSS tones or DPL codes and a 9-character alphanumeric title.
4. 2 guard channels which can each be programmed with a Rx frequency with 25 or 12.5 kHz channel spacing, CTCSS Tx tone or DPL code and a 9-character alphanumeric title.
5. Scanning of preprogrammed memories with selective memory scanning, in 5 scan lists.
6. Priority scan of memory channel 1, if desired.
7. Direct frequency entry mode.
8. Receive frequency simplex function.
9. Switchable RF output power between 1 watt and 8-10 watts.
10. Lockout of keyboard to prevent inadvertent entries.
11. Variable frequency mode to manually scan up and down in 2.5 kHz steps.
12. LED display variable dimming mode.
13. Selectable 90 second Tx time out feature.
14. Quick download of any of the VHF memory positions to the guard memories.
15. PC Memory Upload or Download capability.
16. **Configuration Menu** - Pressing ENTER, RCL and FUNC together while turning the radio on will put it into configuration mode. The programming features affected are:
 - a) **DPL** - Can be turned on or off with the MUP and MDN (4 and 7) keys. This only removes the DPL entry step from the programming sequence and does not stop memories that already have DPL codes from working. This also applies to the rest of the on/off configurable items.
 - b) **SCAN** - Can be disabled. Selecting FUNC and SCAN will do nothing if Scan is off. The scan list indicator (+) will still display if was previously programmed.
 - c) **Rx CTCSS** - Can be turned on or off from the programming sequence. This affects only the CTCSS tones for receive.
 - d) **FUNC 7** - Can be turned on or off. When off, the main memory channel can not be dumped into one of the guard channels using function 7.
 - e) **LAST MEM** - If set to on, the last memory channel on the display will be what comes up when the radio is turned on. If set to off, the last memory that changes were made to will be what comes up when the unit is switched on.
 - f) **DUALMODE** - If set to on, the VLO and VHF bands are operated independently and simultaneously. The radio is shipped with this feature OFF.

- g) **SIDETONE** - The TX audio circuit becomes active allowing you to adjust the sidetone level with the VHF volume knob. When the desired level is reached, press ENTER and this level will be set for both VHF and VLO bands. The factory setting is 23.

Important: You must set the side tone every time you go through the configuration menu since the position of the knob is taken as the new level regardless of whether or not you made an adjustment.

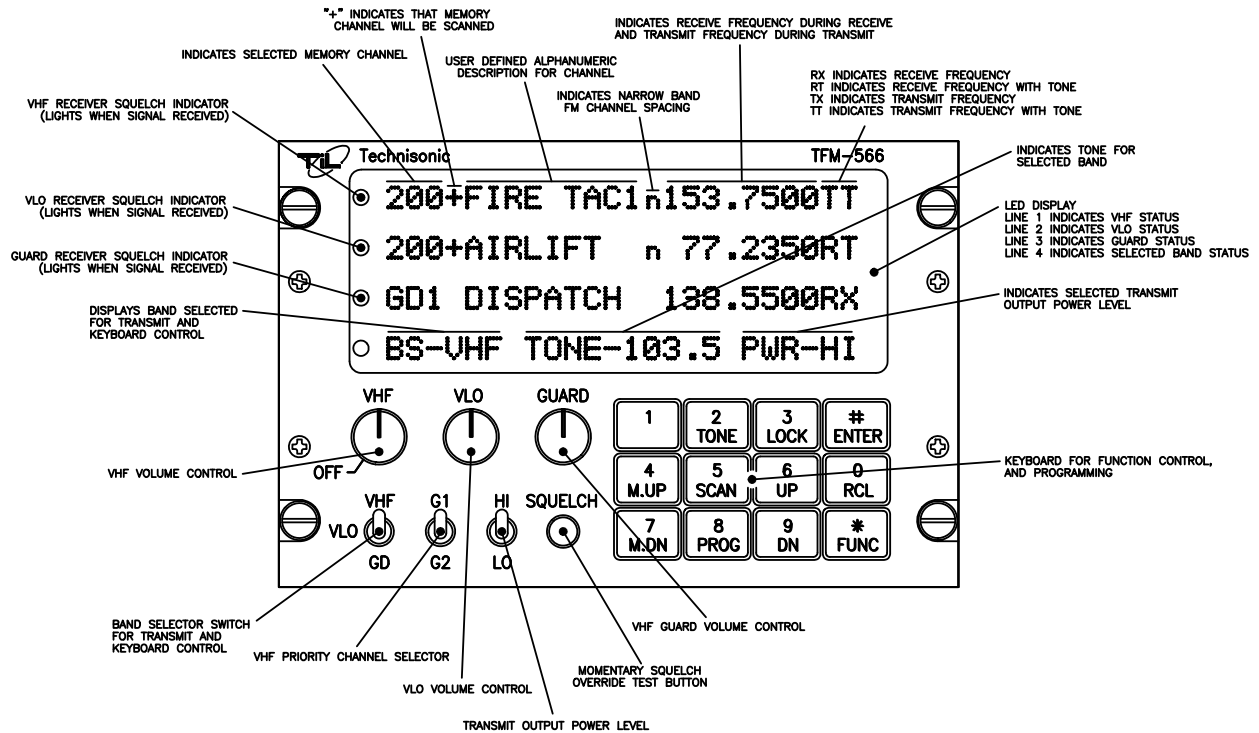

FIGURE 2.1 Operator's Switches and Controls

2.2 OPERATING INSTRUCTIONS (See Figure 2.1)

1. Switch power on by turning the main volume clockwise. Depending how the radio is configured, either the last programmed or last displayed frequencies will appear on the screen. The transceiver is now in normal operating mode.
2. Adjust the audio level by adjusting the VHF, VLO and GUARD volume knobs.
3. Pressing the squelch defeat button will open all receivers to confirm they work.
4. Read the display. The top line will indicate which VHF memory is selected followed by a "+" if the memory position is included in a scan list, an alphanumeric message, and the frequency of the VHF receiver. A small "n" before the frequency indicates 12.5 kHz narrowband channel spacing is in effect on this memory position. In the receive mode, the frequency is followed by an "RT" if a RX CTCSS tone or RX DPL code is programmed, or an "RX" if no Receive tone/code is programmed. Similarly, in the transmit mode either a "TT" or "TX" is shown after the frequency. The second line shows the same information for the VLO band. The third line indicates information about the VHF guard receiver.
5. Only TX CTCSS tones or TX DPL codes may be programmed for the guard receiver. At the beginning of each line, an LED indicates open squelch.
6. Set the VHF/VLO/GD switch to the desired band.
7. Set the G1/G2 switch to the desired guard channel.
8. Set the HI/LO switch to the desired RF output power.
9. Select the desired memory by using the M.UP and M.DN buttons, or the RCL button and a three digit number followed by ENTER.
10. To transmit DTMF tones, use the keyboard keys while holding the PTT button on the microphone. There is a 5 second PTT delay after pressing a key so that you may press several DTMF keys in sequence without having to hold the PTT. The keyboard returns to its normal function when the PTT is released.

The display always shows the status of both receivers and the transmitter. The light at the left of each line indicates which receiver is receiving. The display also indicates the memory channel in use and the guard channel in use. A "TX" (no TX tone/codes programmed) or "TT" (either TX tone or code programmed) on the right side of the display indicates which band is active when transmitting. The transmit frequency is also shown. In the receive mode the display shows "RX" beside the receive frequency if no RX tone or DPL code is programmed and "RT" if a CTCSS tone or DPL code is programmed.

While in any programming mode, all receivers continue to function. When the transceiver is in either of the operating frequency or CTCSS tone/DPL code programming modes and you must respond to a call, click the microphone PTT once (the radio will not transmit during this click). This will cause the transceiver to revert back to the normal operating mode and communications with the caller can proceed in the usual fashion.

2.3 PROGRAMMING INSTRUCTIONS

To program one of the 200 memory channels in one of the bands:

1. Select the desired band on the band select (VHF/VLO/GD) switch. This is required before any of the programming modes or functions.
2. Press the **FUNC** key. The display will show the function prompt.
3. Press the **PROG** key. The display will show the current receive frequency with a flashing cursor on the first or second digit (The first digit is always a one <1> on the VHF band).
4. Type in the desired receive frequency. If you type in a frequency which is not a 2.5 kHz step, the nearest valid frequency will be automatically selected.
5. The cursor will return to the second digit. You can retype the frequency if you have made an error or press **ENTER** to continue.
6. The transmit frequency will be displayed with the cursor on the second digit. Follow the same method as in step 3 and 4.
7. The channel spacing increment of either 25.0 or 12.5 kHz is now displayed. Use the **M.UP** and **M.DN** keys to select the desired channel spacing for the memory position, then press **ENTER**.
8. The alpha-numeric title is now displayed. Use the **M.UP** and **M.DN** keys to scroll through the alphabet, numbers and symbols. When the desired character is displayed, press **ENTER** to advance to the next character. Press "1" to backspace.
9. Keep repeating step six until the last space is set. The display will show SCAN or LOCKOUT to enable this memory position as part of a scan list or lock it out of the scan list. Use the **1,2,3,4,5** and **M.DN** keys to toggle between these functions (for details see paragraph 2.5). Once the desired condition has been selected, press **ENTER**. The TFM-566's display will show a "+" beside the memory channel number if scan is enabled.
10. The display will now show the current memory number. Type in the 3-digit number of the memory you want to save to (if different from displayed one) and press **ENTER**.
11. You now have the option to program the guard frequencies by pressing **FUNC** or press **ENTER** to return to normal operating mode.
12. If you pressed **FUNC** to program the guards, guard"1" transmit frequency will be displayed with the flashing cursor on the second digit. Enter the frequencies for guard"1" receive/transmit and guard"2" receive/transmit as in step 3 and 4.
13. The alphanumeric labels for guard"1" and guard"2" are entered the same as in step 7 and 8. When the last character is entered, the radio returns to normal operating mode.

2.4 PRIORITY SCANNING, SELECTIVE MEMORY CHANNEL SCANNING & SCAN LISTS

Instead of breaking up the 200 channels into blocks for scanning, the TFM-566 has 5 scan lists per band. Any of the 200 channels can be assigned to any one or more of these 5 scan lists. This means the channels do not have to be repeated to be in more than one block and that you are not limited to the number of channels that you can scan at once.

The priority memory channel is always memory position number 1. The priority memory channel is scanned every other step (i.e. 121314151...) to ensure that no incoming messages are missed. The priority channel can be locked out, which will result in the normal scanning of the other memory positions.

Selective memory scanning allows the user to select which of the 200 memory channels are to be scanned or locked out when the scan function is invoked. To use this feature, follow the PROGRAMMING INSTRUCTIONS found in paragraph 2.3. Once the screen displays **SCAN** or **LOCKOUT**, use the **1,2,3,4,5** or **M.DN** keys to toggle to the desired condition. The **MDN** button acts as a clear while pressing one or more of the above numbers adds the memory to the corresponding scan list or lists. Press **ENTER** when you are happy with your selection. In normal operating mode the display will later show a "+" beside the memory channel number if it has been included in any of the 5 scan lists.

NOTE: Scanning can only be performed on one band (either VHF or VLO) at a time. When the transceiver is in the single mode (combined VHF and VLO audio) and the scan feature has been invoked on one band, it will be interrupted when transmitting on the other band. In the Dual mode, you are able to transmit on the second band without affecting the scan function on the first.

2.5 SCANNING FUNCTION (5 second talkback delay)

Select the band you wish to scan with the band switch. (you can not scan the guard) To start scanning of the memory channels, press **FUNC** then **SCAN** and then the number (1,2,3,4,5) of the desired scan list.

The radio will scan through all the preset memory positions in the selected scan list (see above paragraph for priority and selective scan features) and will lock on to the first active channel in the scan sequence. It will remain on the channel until it becomes inactive. Scanning will resume again after five seconds of inactivity. To exit the scan mode, press the **SCAN** key. This will cause the radio to revert back to the normal operating mode.

If while scanning, you hear a call for you:

1. Respond to the call within 5 seconds. When scanning is interrupted by an incoming signal, the channel will remain open for five seconds before resuming scanning.
2. During communications the five second timer is reset from the last Rx or Tx signal encountered.

The radio resumes scanning once the Rx or Tx activity has ceased for more than five seconds. The **SCAN** key must be pressed to exit the scan mode.

2.6 DIRECT FREQUENCY ENTRY MODE

This mode is designed to facilitate quick frequency selection during emergency and other operational conditions requiring direct operating frequency selection. This operating mode is disabled along with the programming mode when the internal disable jumper is set.

1. When the transceiver is in the normal operating mode, press **FUNC** and the desired operating frequency i.e. **153.2750**.
2. On the VLO band press **FUNC** and then **1** and the desired frequency i.e. **73.5500**.
3. You will then be asked for 12.5 or 25.0 kHz channel spacing. Select with **MUP** or **MDN** and press **ENTER**.

Please note in the above operation, after **FUNC** and "**1**" are entered, the LED display will show memory channel "000" and then the remaining digits in the desired frequency are shown as they are entered. No alphanumeric message can be entered in this mode. Operation on the new frequency occurs in both transmit and receive (simplex only) modes. If RX or TX CTCSS tones/DPL codes are required they must be programmed in afterwards.

2.7 RECEIVE FREQUENCY SIMPLEX (TALK AROUND) FUNCTION

The receive frequency simplex function allows you to quickly change the transmit frequency, when operating on a split pair (repeater/semi-duplex mode), to the receive frequency to allow direct communications. i.e. If you are transmitting on 152.000 MHz and receiving 152.555 MHz, select **VHF** on the band select switch and press **FUNC** then **UP** to transmit on 152.555 MHz. To return to the split pair condition, you must recall the memory channel again. This is quickly done by pressing **M.UP** for one step up, then back down one step with the **M.DN** key.

2.8 KEYBOARD LOCKOUT FUNCTION

The keyboard can be locked out so that accidental pressing of keys does not change frequency, etc., unknowingly to the operator. To lock the keyboard, press **FUNC** then **LOCK**. This will disable all keyboard functions (except keyboard unlock) in the receive mode. The DTMF function during transmit will not be affected. To unlock the keyboard, press and hold the **LOCK** key for two seconds until the display indicates "UNLOCK".

2.9 VARIABLE FREQUENCY MODE FUNCTION

To enter variable frequency mode, press **RCL, 0,0,0**, then **ENTER** or enter a frequency in the direct entry mode described above. The memory channel that you were just in will still be valid but now you can manually adjust the frequency with the **M.UP**, **M.DN**, **UP** and **DN** keys. The **UP** and **DN** keys will make the frequency count up or down in steps of 2.5 kHz. The **M.UP** and **M.DN** keys will make the frequency count up or down in steps of 1 MHz. You can not change the label. The frequency in this mode is not stored in memory. To exit this mode, recall one of the 200 memory channels (i.e. **RCL, 0,0,1**). Variable frequency mode is disabled when the internal entry disable jumper is set.

2.10 LED DISPLAY VARIABLE DIMMING MODE

1. With the transceiver in normal operating mode press the UP or DN keys to increase or decrease the intensity of the LED display.
2. Once maximum intensity of the display is achieved, the UP key no longer functions. Conversely, once minimum intensity is reached, the DN key ceases to function.

2.11 90 SECOND TRANSMITTER TIME OUT FEATURE

A selectable 90 second transmitter time out feature is provided to prevent accidental continuous transmission in the event of a faulty PTT switch. With this feature enabled the transceiver will stop transmitting after the PTT is engaged continuously for 90 seconds. The timer is reset by releasing then re-engaging the PTT switch.

Press the FUNC then the M.UP key. Use the M.UP and M.DN keys to select 90 SEC, which enables the feature, or NONE which disables it.

2.12 QUICK GUARD PROGRAMMING FEATURE

A quick download of any of the 200 VHF memory positions into either of the guard memory positions can be accomplished. Select the memory position whose contents you desire to download to a guard memory. Select either GD1 or GD2 memory channel as desired. Press FUNC then 7. The guard memory channel will now contain all the same information as the selected memory position. This feature is disabled when the FUNC 7 mode is turned off in the configuration menu.

2.13 PROGRAMMING CTCSS TONES/DPL CODES

CTCSS tones (PL tones) or Digital DPL codes can be assigned to each memory channel. The guard receiver squelch will operate on noise squelch only, but guard 1 and 2 transmit tones or codes can be programmed. To program a tone/code to a memory channel:

1. Select the desired band on the band select switch.
2. Use the M.UP and M.DN keys to select the memory channel that you want to assign a CTCSS tone or DPL code.
3. Press the FUNC key then the TONE key. The display will show "RX TONE:" and the current tone number, as well as the tone frequency in Hz.
4. Use the M.UP and M.DN keys to select the tone number you require. The following is a list of the available CTCSS tones:

<u>Number</u>	<u>Tone</u>	<u>Number</u>	<u>Tone</u>	<u>Number</u>	<u>Tone</u>
01	67.0	26	162.2	51	177.3*
02	71.9	27	167.9	52	183.5*
03	74.4	28	173.8	53	189.9*
04	77.0	29	179.9	54	196.6*
05	79.7	30	186.2	55	199.5*
06	82.5	31	192.8	56	206.5*
07	85.4	32	203.5	57	210.7*
08	88.5	33	33.0*	58	218.1*
09	91.5	34	35.4*	59	225.7*
10	94.8	35	36.6*	60	229.1*
11	97.4	36	37.9*	61	233.6*
12	100.0	37	39.6*	62	241.8*
13	103.5	38	44.4*	63	250.3*
14	107.2	39	47.5*	64	No Tone
15	110.9	40	49.2*		(carrier squelch only)

TECHNISONIC INDUSTRIES LIMITED

www.til.ca

16	114.8	41	51.2*	(The tones marked with * are nonstandard tones).
17	118.8	42	53.0*	
18	123.0	43	54.9*	
19	127.3	44	56.8*	
20	131.8	45	58.8*	
21	136.5	46	63.0*	
22	141.3	47	69.4*	
23	146.2	48	159.8*	
24	151.4	49	165.5*	
25	156.7	50	171.3*	

5. Press ENTER. "TX TONE" appears on the display. Repeat step 3.
6. Press ENTER. "G1 TONE" appears on the display. Repeat step 3.
7. Press ENTER. "G2 TONE" appears on the display. Repeat step 3 and press ENTER.
8. The display will now show "RX DPL:" and the current 3-digit DPL code. If no DPL code is required "000" should be entered. Please note that if a DPL code is to be programmed a CTCSS tone should not be enabled.
9. Use the keypad to enter the required octal 3-digit DPL (Digital Coded Squelch or DCS) code. A list of all usable and unique octal 3-digit DPL/DCS codes follows:

017*	051	116	156	243	266*	346	431	466	612	721
023	053*	122*	162	244	271	351	432	503	624	731
025	054	125	165	245	274*	356*	445	506	627	732
026	065	131	172	246*	306	364	446*	516	631	734
031	071	132	174	251	311	365	452*	523*	632	743
032	072	134	205	252*	315	371	454*	526*	654	754
036*	073	143	212*	255*	325*	411	455*	532	662	
043	074	145*	223	261	331	412	462*	546	664	
047	114	152	225*	263	332*	413	464	565	703	
050*	115	155	226	265	343	423	465	606	712	

• indicates GE Digital Coded Squelch (DCS) Code

10. Press ENTER. "TX DPL" appears on the display. Repeat step 9.
11. Press ENTER. "G1 DPL" appears on the display. Repeat step 9.
12. Press ENTER. "G2 DPL" appears on the display. Repeat step 9 and press ENTER.

2.14 PC MEMORY PROGRAMMING UP/DOWNLOAD CAPABILITY

The TFM-566 transceiver can be programmed by a Windows based personal computer using Technisonic software supplied on CD with each TFM-566.

Requirements:

1. PC compatible computer with a CD ROM drive, running Windows 95/98 /NT/2000 /ME/XP.
2. Bench power supply of 28 volts DC.
3. PC download cable, P/N 993390-1 which can be supplied or made from the wiring diagram at the back of this section.

Connections:

1. With the PC turned off, plug the 25 pin male 'D' connector into a serial port.
2. Plug the 9 pin 'D' connector into the back of the TFM-566 transceiver.
3. Connect the power supply to the TFM-566.

Installing the MultiTDP Program:

The CD supplied with each radio contains software for all of Technisonic's downloadable transceivers. Place the CD into your drive and use Windows Explorer to open the MultiTDP directory on the CD. Double click the **MultiTDP_Install.exe** file. Follow the onscreen instructions to install the program onto your hard drive. When the program is installed, it can be run by selecting **Programs** from your **Start** menu, then select **Technisonic** from the submenu and finally **MultiTDP**.

Using the MultiTDP Program:

With the program running on your computer, a full MultiTDP instruction manual can be loaded by selecting **Documentation in PDF format** under the Help menu. Otherwise, to get started, pull down the **File** menu and select **TFM-566**. The program defaults to serial port com1 but can be set to **com2, 3 or 4** under the **Com Port** menu. The program is now ready to use. You may want to upload data from the radio and edit channels or start a new data file. The VHF and VLO bands are treated as separate radios and must be up or downloaded and edited separately. Editing is done on a channel by channel basis. Set the channel number you would like to edit and then modify the frequencies, labels, CTCSS tones, DPL codes, wide / narrow band setting and scan lists as desired. Press the **Save Record** button to store the changes you've made to the database below. After you have edited the channel list you can save your changes to disk and/or download to the radio. Only channels selected with a check mark will download.

It is recommended to use the **Select All** command in the **Data Transfer** menu to ensure the data base in the radio matches the one in the PC. When download is selected, a message box will appear on your screen asking you to press **FUNC** and **DN** on the radio. Press these buttons on the radio before you click **OK** in the message box, otherwise the download will fail.

**TFM-566 Upload/Download Programming Cable
P/N 993390-1 Wiring Diagram**

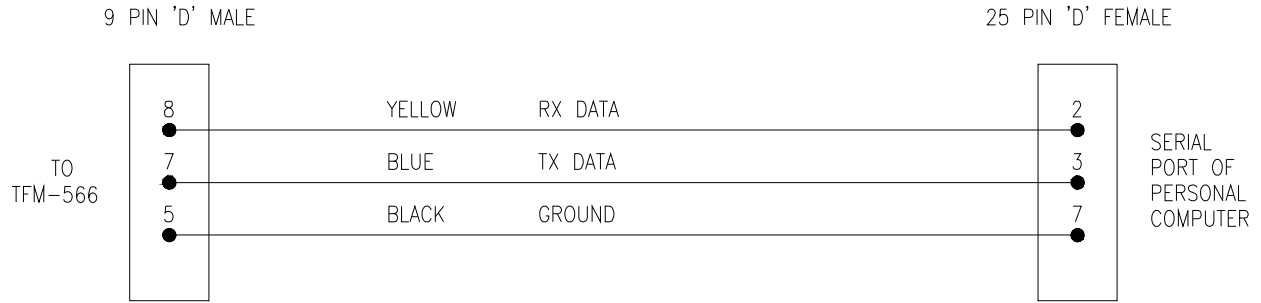

Note: If your serial port is a 9 pin connector, instead of the 25 pin use a female 9 pin D connector, connecting:

Yellow - pin 3
Blue - pin 2
Black - pin 5

FIGURE 2.2 TFM-566 Transceiver PC Up/Download Cable - wiring diagram

SECTION 3 – INSTALLATION INSTRUCTIONS

3.1 GENERAL

This section contains information and instructions for the correct installation of the TFM-566, VHF/FM Transceiver. Make certain that the correct frequencies are pre-programmed in accordance with the equipment user's valid FCC operator's license, prior to installation.

3.2 EQUIPMENT PACKING LOG

Unpack the equipment and check for any damage that may have occurred during transit. Save the original shipping container for returns due to damage or warranty claims. Check that each item on the packing slip has been shipped in the container. Verify that the equipment display and backlighting configuration are the same as those ordered.

3.3 TRANSCEIVER INSTALLATION

The TFM-566 transceiver is designed to be Dzus mounted and should be installed in conjunction with a IN-550 installation kit. See Figure 3.1 for an outline drawing of the unit with dimensions to facilitate the installation.

3.4 INSTALLATION KIT - CONTENTS

The IN-550 installation kit consists of:

1. One 15 pin Cannon D mating connector (female) complete with crimp pins and hood.
2. One 9 pin Cannon D mating connector (male) complete with crimp pins and hood.
3. Three BNC antenna mating RF connectors (male).

3.5 ANTENNA INSTALLATION

Antenna, Comant P/N CI-292-3 or suitable equivalent may be utilized for VHF and the Foxtronics model FLX-6688B antenna and tuning system for the VLO band. A suitable whip antenna cut for a specific VLO frequency may also be used. The antenna should be mounted on the bottom of the aircraft whenever possible. Consult with instructions provided with the antennas. Connect RF cables from antennas to the back of the TFM-566 unit by utilizing the BNC connectors provided in the installation kit. The VLO connector is located on the rear, above the 15-pin D connector and the VHF connector is below the 9-pin D.

3.6 INSTALLATION – PIN LOCATIONS AND CONNECTIONS

The pin numbers and locations for the 15 pin and 9 pin Cannon D located on the rear of the TFM-566 transceiver are shown below. Pin connections are in provided in TABLE 3.1.

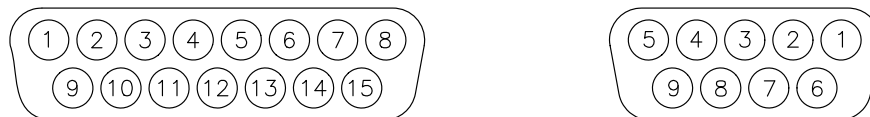

FIGURE 3-0 Transceiver mounted view of 15-pin female and 9-pin male connector

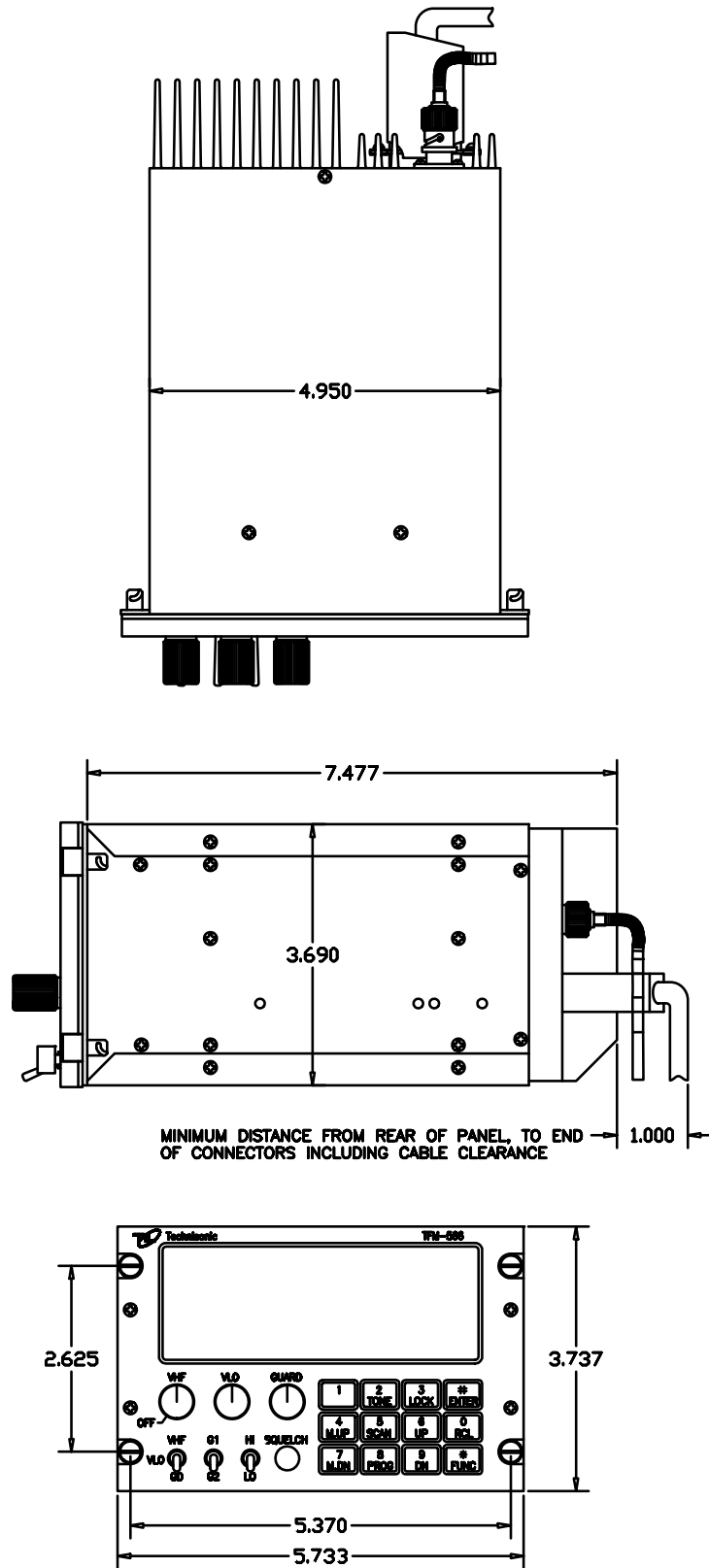

FIGURE 3.1 Outline Drawing for Model TFM-566 Series Transceivers

3.6 INSTALLATION - PIN LOCATIONS AND CONNECTIONS (continued)

15-Pin D Connections - Use FEMALE Connector	
Pin #	Description
1	600 Ohm Output 1
2	Data Output
3	Panel Lighting (28VDC or 5VAC)
4	Memory Up
5	Memory Down
6	Mic Signal Input 1
7	Main Power + 28VDC
8	Main Ground
9	4 ohm Speaker Output
10	4 ohm/600 ohm Output Ground
11	Data Input
12	DF Audio
13	PTT 1 (Ground Keying)
14	Main Power + 28VDC
15	Main Ground

9-Pin D Connections - Use MALE Connector	
Pin #	Description
1	600 Ohm Output 2
2	PTT 2 (Ground Keying)
3	Reset
4	Background Debug Signal
5	Ground
6	Programming Voltage In
7	Serial Data Out
8	Serial Data In
9	Mic Signal Input 2

TABLE 3.1 Wire connections on a 15-and 9-pin D-Connector

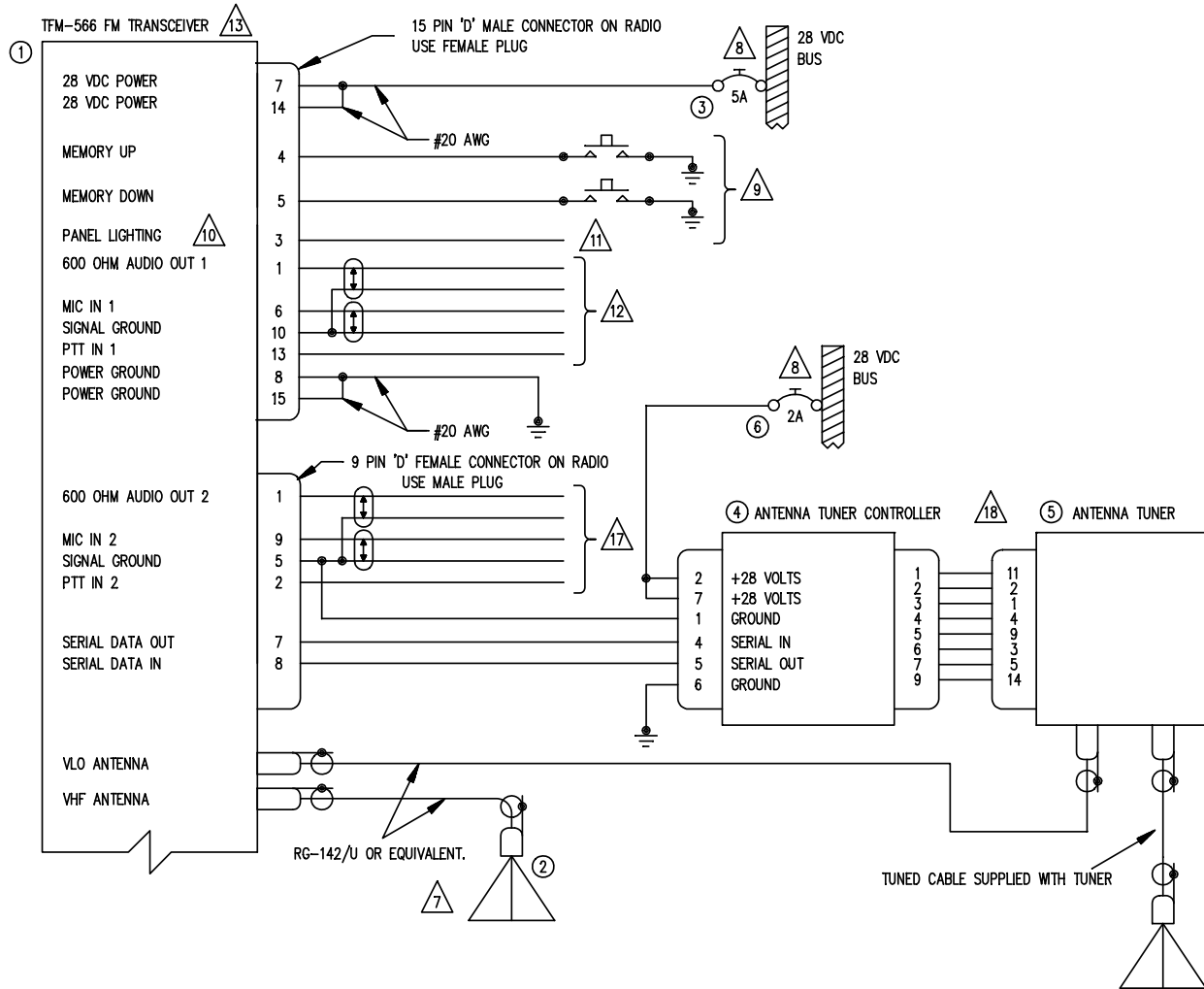

FIGURE 3.2 Wiring connections for the TFM-566 Transceiver

TECHNISONIC INDUSTRIES LIMITED

www.til.ca

QTY	ITEM	PART NOS.	DESCRIPTION	SPEC	MATERIAL
1	1	TFM-566	VHF/VLO FM COMMUNICATIONS TRANSCEIVER.	TECHNISONIC INDUSTRIES LTD	
1	2	CI-293-3	ANTENNA – VHF FM BENT WHIP	COMANT	
1	3	7274-11-5	CIRCUIT BREAKER, 5 AMPS	KLUXON	
1	4	ATC-550	ANTENNA TUNER CONTROLLER	TECHNISONIC INDUSTRIES LTD	
1	5	FLX-6688B	ANTENNA AND TUNER SYSTEM	FOXTRONICS	
1	6	7274-11-2	CIRCUIT BREAKER, 2 AMPS	KLUXON	

NOTES:

- 1) ALL WIRE IAW MIL-W-22759 UNLESS OTHERWISE SPECIFIED.
- 2) ALL CABLE IAW MIL-C-27500 UNLESS OTHERWISE SPECIFIED.
- 3) COAXIAL CABLE IAW MIL-C-17 UNLESS OTHERWISE SPECIFIED. DO NOT USE COAX WITH PVC INSULATION.
- 4) FABRICATION & INSTALLATION OF WIRING HARNESS IAW AC 43.13-1B CHAPTER 11
- 5) GROUNDING AND BONDING IAW AC 43.13-1B CHAPTER 11, SECTION 15.
- 6) ALL SINGLE WIRE TO BE #22 AWG MINIMUM AND ALL SHIELDED WIRES TO BE #24 AWG MINIMUM, UNLESS OTHERWISE SPECIFIED.
- 7) INSTALLATION OF ANTENNA IAW AC 43.13-1B CHAPTER 4, SECTION 4, CHAPTERS 6 & 7, AND AC 43.13-2A CHAPTER 3. IF POSSIBLE, THE ANTENNA SHOULD BE LOCATED A MINIMUM OF 12 FT FROM AIRCRAFT NAVIGATION RECEIVER ANTENNAS AND A MINIMUM OF 4 FEET FROM AIRCRAFT COMMUNICATIONS AND ELT ANTENNAS. BE CAREFUL NOT TO CHOSE SEPARATIONS THAT CLOSELY APPROXIMATE 1/4 OR 1/2 OR WHOLE NUMBER MULTIPLES OF THE NAVIGATION OR COMMUNICATIONS SYSTEM WAVELENGTH.
- 8) AN EQUIVALENT CIRCUIT BREAKER OR FUSE MAY BE USED.
- 9) THE MEMORY UP/DOWN PUSH BUTTONS ARE OPTIONAL.
- 10) THE TFM-566 IS AVAILABLE WITH 28V OR 5V PANEL LIGHTING. CHECK THE CONFIGURATION CONTROL LABEL FOR THE CORRECT VOLTAGE.
- 11) CONNECT TO THE APPROPRIATE AIRCRAFT DIMMING BUSS.
- 12) CONNECT TO THE AIRCRAFT AUDIO SYSTEM OR STAND-ALONE HEADSET JACKS.
- 13) INSTALLATION OF TRANSCEIVER IAW AC 43.13-1B CHAPTER 4, SECTION 4 AND AC 43.13-2A, CHAPTER 2. PR 3 1/2 DZUS RAIL OR EQUIVALENT MAY BE USED.
- 14) TEST THE SYSTEM IN ACCORDANCE WITH THE POST-INSTALLATION TEST PROCEDURE IN THE INSTALLATION AND OPERATING INSTRUCTIONS MANUAL.
- 15) REFER TO THE AIRCRAFT STRUCTURAL REPAIR MANUAL AND THE MAINTENANCE MANUAL FOR INSTRUCTIONS AND INFORMATION PERTINENT TO THIS INSTALLATION.
- 16) THE USE OF RED DISPLAYS SHOULD BE MINIMIZED OR AVOIDED SO AS NOT TO DETRACT FROM THE ATTENTION GETTING CHARACTERISTICS NEEDED IN WARNING AND CAUTION ANNUNCIATORS. RED SHOULD BE USED TO ANNUNCIATE EMERGENCY CONDITIONS REQUIRING IMMEDIATE RESPONSE BY THE FLIGHT CREW. UNITS WITH RED DISPLAYS SHOULD NOT BE LOCATED IN CLOSE PROXIMITY TO WARNING AND CAUTION ANNUNCIATORS. THE INSTALLATION OF UNITS WITH RED DISPLAYS MUST BE EVALUATED ON A CASE BY CASE BASIS TO ENSURE THAT THE EFFECTIVENESS OF THE WARNING AND CAUTION ANNUNCIATORS IS NOT ADVERSELY AFFECTED.
- 17) ONLY USED IF THE TRANSCEIVER WILL BE OPERATED IN DUAL MODE. (OPERATION OF 2 BANDS INDEPENDENTLY)
- 18) INSTALL ANTENNA TUNER AND ANTENNA TUNER CONTROLLER IAW AC 43.13-1B CHAPTER 4, SECTION 4 AND AC 43.13-2A CHAPTER 2.
- 19) REFER TO ANTENNA TUNER AND ANTENNA TUNER CONTROLLER INSTALLATION MANUALS FOR MORE DETAILED INSTRUCTIONS.

FIGURE 3.2 Wiring connections for the TFM-566 Transceiver (continued)

3.7 WIRING INSTRUCTIONS

Figure 3.2 shows all required connections and recommended wire sizes for the TFM-566 Transceiver.

3.7.1 Main Power + 28VDC

The main power +28VDC ($\pm 15\%$) is connected to pins 7 and 14 of the transceiver. Both pins should be connected.

3.7.2 Main Ground

Ground connections are made on pins 8 and 15. Both pins should be connected.

3.7.3 PTT (Ground Keying)

The PTT line is connected to pin 13 and should be floating when the transceiver is in receive mode, and grounded during transmit mode. The PTT2 input is on pin 2 of the 9 pin connector.

3.7.4 Front Panel Back Lighting

Front panel back lighting connection should be made on pin 3 of the transceiver. The opposite end of this lead should be connected to the panel lighting system of the aircraft. Before connecting, verify the required panel lighting voltage (28 VDC or 5VAC) on the transceiver configuration control label.

3.7.5 Audio Outputs (600 ohms and 4 Ohms)

There are two audio outputs available (1 & 2). 600 ohm audio output 1 has audio from both bands and the guard in single operator mode. When in dual operator mode, 600 ohm output 1 has audio from the VHF band and guard only while the VLO audio will be on the 600 ohm output 2.

3.7.6 Audio Output Ground

Pin 10 is the ground for both the 4 ohm and 600 ohm audio output signals.

3.7.7 Mic Signal Input

The microphone input signal is to be provided on pin 6, utilizing shielded wire with the shield grounded to pin 10. Microphone signal 2 is on pin 6 of the 9-pin D connector.

3.7.8 Memory Up/Memory Down

Remote scrolling through the 200 memory positions can be achieved by providing a ground to pins 4 (up) and 5 (down) through a momentary contact cyclic switch. The memories will scroll only on the band selected.

3.7.9 Data Input

Data communications equipment requiring direct access to the VHF modulator and discriminator and can be connected via pins 2 and 11. Data cannot be transmitted in CANADA unless equipment is approved for use with the TFM-566 by the communications regulatory authority.

3.8 INTERNAL PROGRAMMING AND GUARD ENABLE/DISABLE JUMPER

The programming and direct frequency entry modes can be disabled by removing the internal enable/disable jumper strap from pins 1 and 2 of J10. Removal of this jumper will prevent operation on any frequencies other than those programmed in the 400 memory positions and two guard receiver memory positions. Removal of the guard receiver programming enable /disable jumper strap from pins 1 and 2 of J11 will totally disable the operator's ability to re-program the 2 guard receiver channels.

The transceiver is always shipped with the two jumpers in the entry enable positions. To place either of the jumpers in the disable position:

1. Remove the left side of the radio.
2. Set or remove jumpers as necessary.
3. Re-install the left side cover.

Microprocessor Control Unit (MCU) PCB Module:

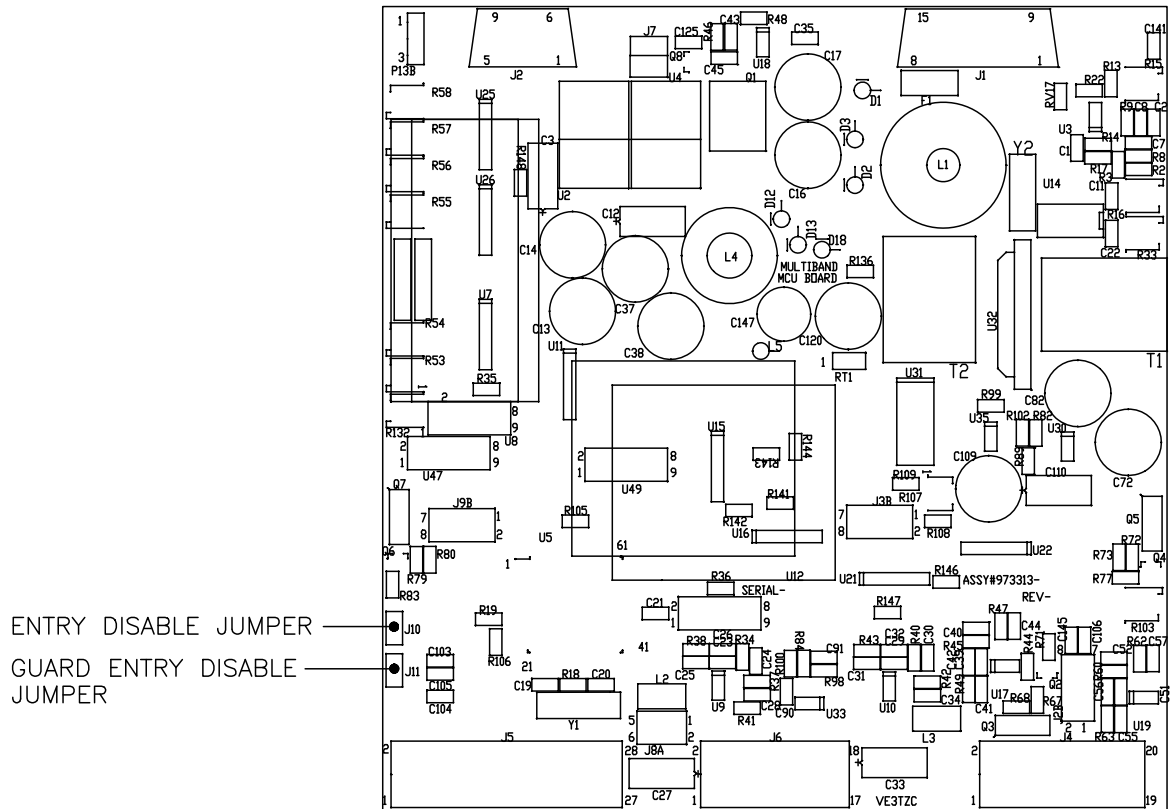

FIGURE 3.3 Internal Enable/Disable Jumper Locations
(The Guard Entry Disable Jumper has no effect to the TFM-556)

3.9 TRANSMITTER POWER ADJUSTMENTS

The transmitter power is adjusted to a maximum of 10 watts in high power mode and 1 watt in low power mode over the transceiver operating bandwidth at the factory. If transmitter RF power re-adjustment is required, perform as follows:

1. Select the band that you wish to adjust on the band select switch.
2. Connect an RF through-line wattmeter to the appropriate antenna connector. Set the operating frequency to 156.000 MHz for VHF or 71.000 MHz for VLO and key the transmitter.
3. In low power mode, set the low power adjustment potentiometer on the left side of the chassis to produce 1.0 watt of RF output power (See Figure 3.3).
4. In high power mode, set high power adjustment potentiometer on the left side of the chassis to produce 9.5 watts of RF output power.
5. Verify that the RF output power is between 9 and 10 watts on 138.000 MHz and 174.000 MHz for VHF or 66.000 MHz and 88.000 MHz for VLO.

3.10 TRANSMITTER MICROPHONE LEVEL ADJUSTMENT

1. Set the transceiver operating frequency to 156.000 MHz and connect an appropriate test receiver to the RF output connector. Ensure that the output of the transceiver is terminated into a proper dummy load.
2. Key the transmitter and input a -10 dBm (0.25 VRMS), 1 kHz audio signal into the microphone input.
3. Adjust the microphone level potentiometer (Mic Level 1) through the access hole located on the right side of the chassis (see Figure 3.4) to produce a 2.7 kHz deviation.
4. Verify that the deviation is at least 2.3 kHz on the following frequencies: 138.000 MHz, 162.000 MHz and 174.000 MHz.
5. For VLO, perform the same procedure using the Mic Level 2 pot on the left side of the transceiver and use the following frequencies: 66.000 MHz, 71.000 MHz and 88.000 MHz.

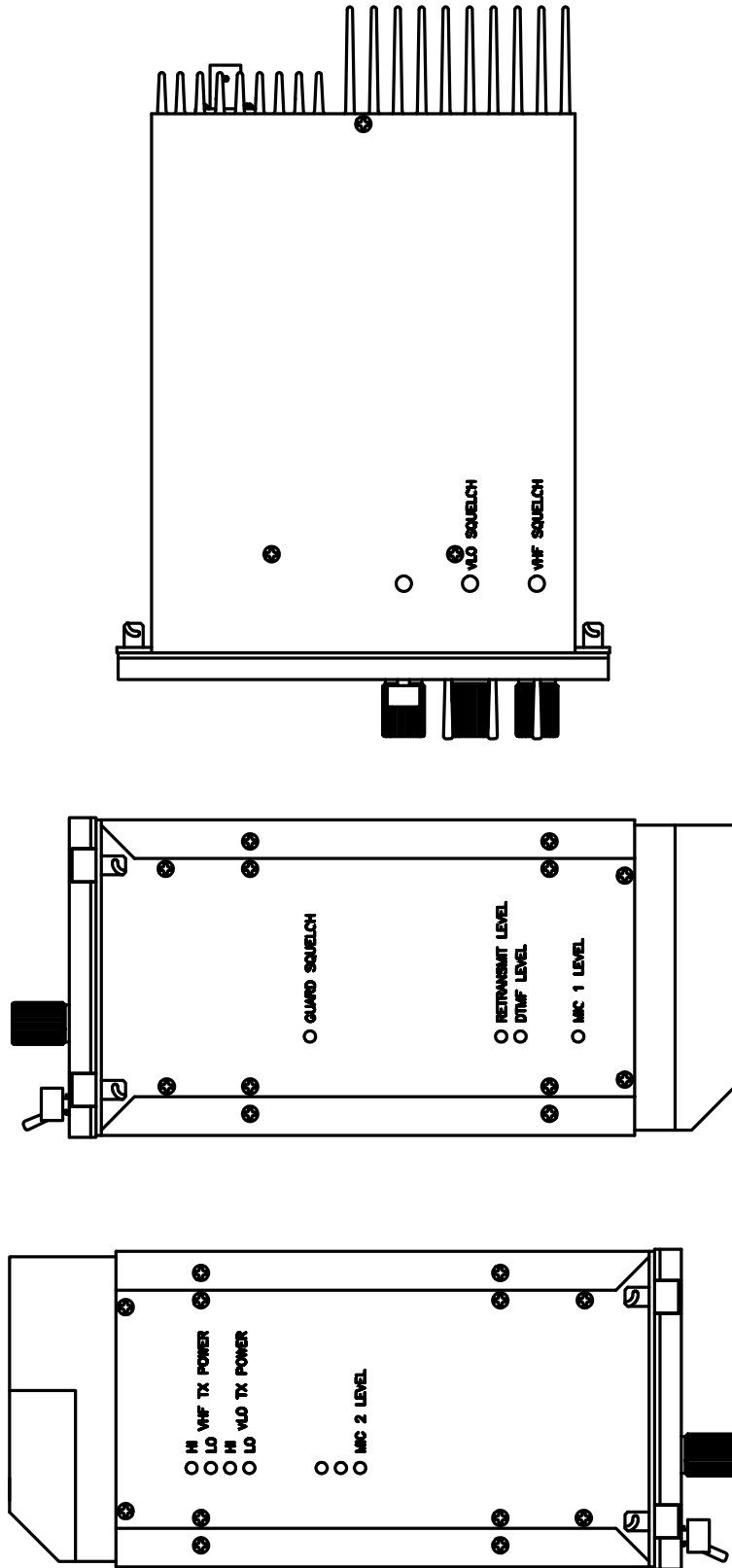

FIGURE 3.4 External Adjustment Access Holes

3.11 SQUELCH ADJUSTMENT

The squelch circuit is designed to open or close depending upon the noise content and not the strength of the received signal. Therefore high squelch settings are not necessary nor possible. The squelch on both the VHF and VLO receivers is factory set to open at approximately 22 dB SINAD, while the guard receiver is set to open at 25 dB SINAD. The range of adjustability is approximately 3 to 27 dB SINAD. This adjustment can be made or altered to suit local conditions as follows:

1. Set the receiver to 157.000 MHz for VHF or 71.000 MHz for VLO. Connect a signal generator to the antenna input of the desired band.
2. Set the signal generator to produce a ± 3 kHz deviation with a 1 kHz tone on 157.000 MHz or 71.000 MHz. Increase the signal generator RF level from 0 uV until the squelch indicator LED is on. Verify the squelch opens at the desired level.
3. If not, re-adjust receiver squelch potentiometer through the access hole located on the bottom or side of the transceiver chassis (see Figure 3.4).

3.12 TRANSMITTER DEVIATION ADJUSTMENT

VHF:

1. Remove the bottom cover of the transceiver.
2. Set the VHF operating frequency to 157.000 MHz and connect an appropriate test receiver to the RF output connector. Ensure that the output of the transceiver is terminated into a proper dummy load.
3. Key the transmitter and input a +10 dBm (2.5 VRMS), 2.5 kHz audio signal into microphone input 1.
4. Adjust the wideband deviation limit potentiometer, R30 on the VHF Rx/Tx module (see Figure 3.5) to produce a ± 4.25 kHz deviation. Select narrow band mode on the VHF band and adjust the narrowband deviation limit potentiometer, R76 on the VHF Rx/Tx module to produce a ± 2.15 kHz deviation.
5. Verify that the deviation does not exceed ± 5 kHz for wideband and ± 2.5 kHz for narrowband on 138.000 MHz, and 174.000 MHz. Re-adjust R30 or R76 as required, if the deviation exceeds ± 5 kHz or ± 2.5 kHz, respectively.
6. Replace the bottom cover.

VLO:

1. Remove the top cover of the transceiver.
2. Unplug the white coax from the guard receiver and remove the front panel.
3. Remove the guard receiver tray.
4. Replace the front panel and select the VLO band.
5. Set the VLO operating frequency to 71.000 MHz and connect an appropriate test receiver to the RF output connector. Ensure that the output of the transceiver is terminated into a proper dummy load.
6. Key the transmitter and input a +10 dBm (2.5 VRMS), 2.5 kHz audio signal into microphone input 1 if in single mode or microphone input 2 if in dual mode.
7. Adjust the wideband deviation limit potentiometer, R21 on the VLO Rx/Tx module (see Figure 3.6) to produce a ± 4.25 kHz deviation. Select narrow band mode on the VLO band and adjust the narrowband deviation limit potentiometer, R16 on the VLO Rx/Tx module to produce a ± 2.15 kHz deviation.

TECHNISONIC INDUSTRIES LIMITED

www.til.ca

8. Verify that the deviation does not exceed ± 5 kHz for wideband and ± 2.5 kHz for narrowband on 66.000 MHz, and 88.000 MHz. Re-adjust R21 or R16 as required, if the deviation exceeds ± 5 kHz or ± 2.5 kHz, respectively.
9. Replace the bottom cover.

VHF Receiver/Transmitter PCB Module

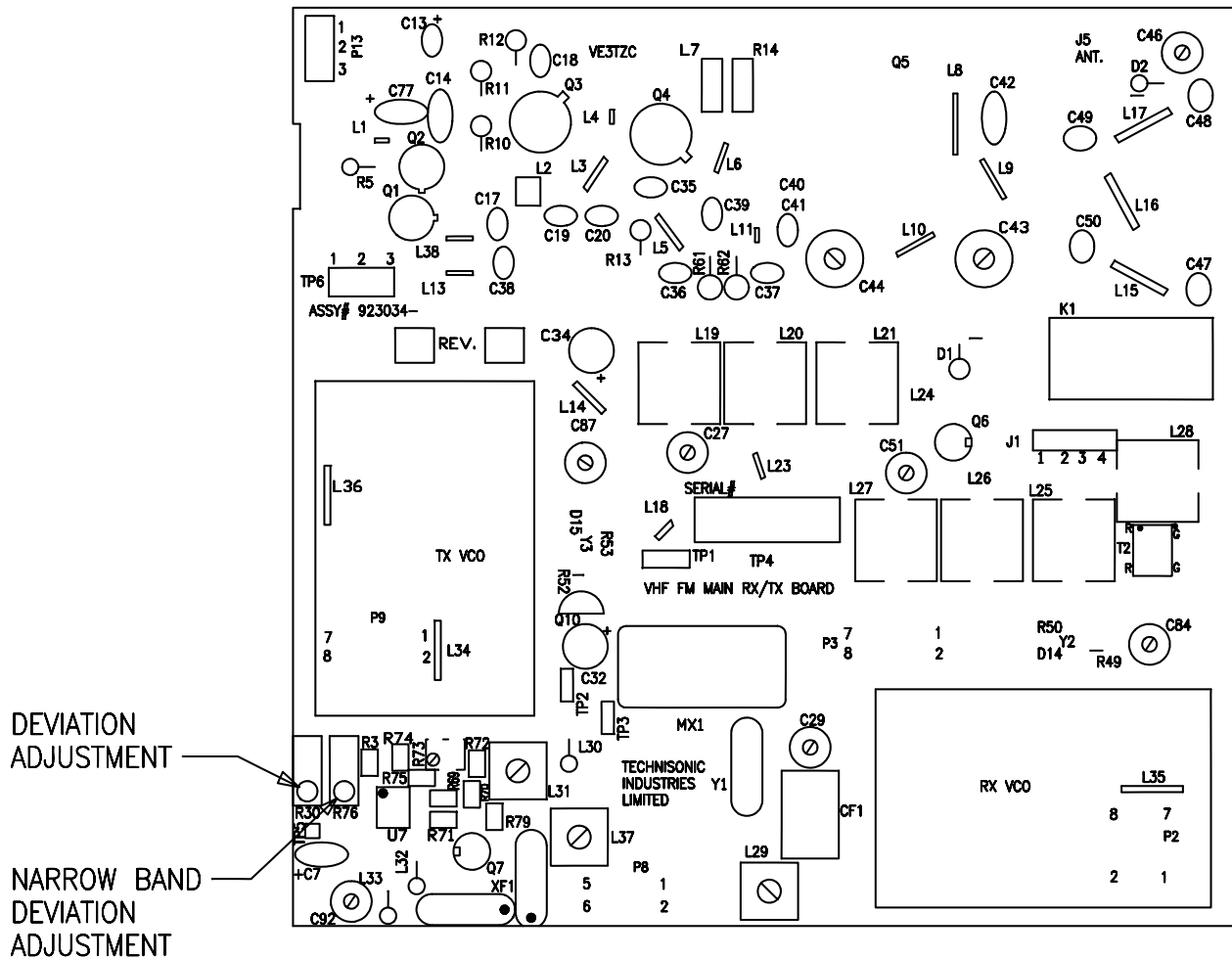

Notes: R30 is for 25 kHz (wideband) Deviation Adjustment
 R76 is for 12.5 kHz (narrowband) Deviaton Adjustment

FIGURE 3.5 VHF Deviation Adjustment Potentiometer Location

VLO Receiver/Transmitter PCB Module

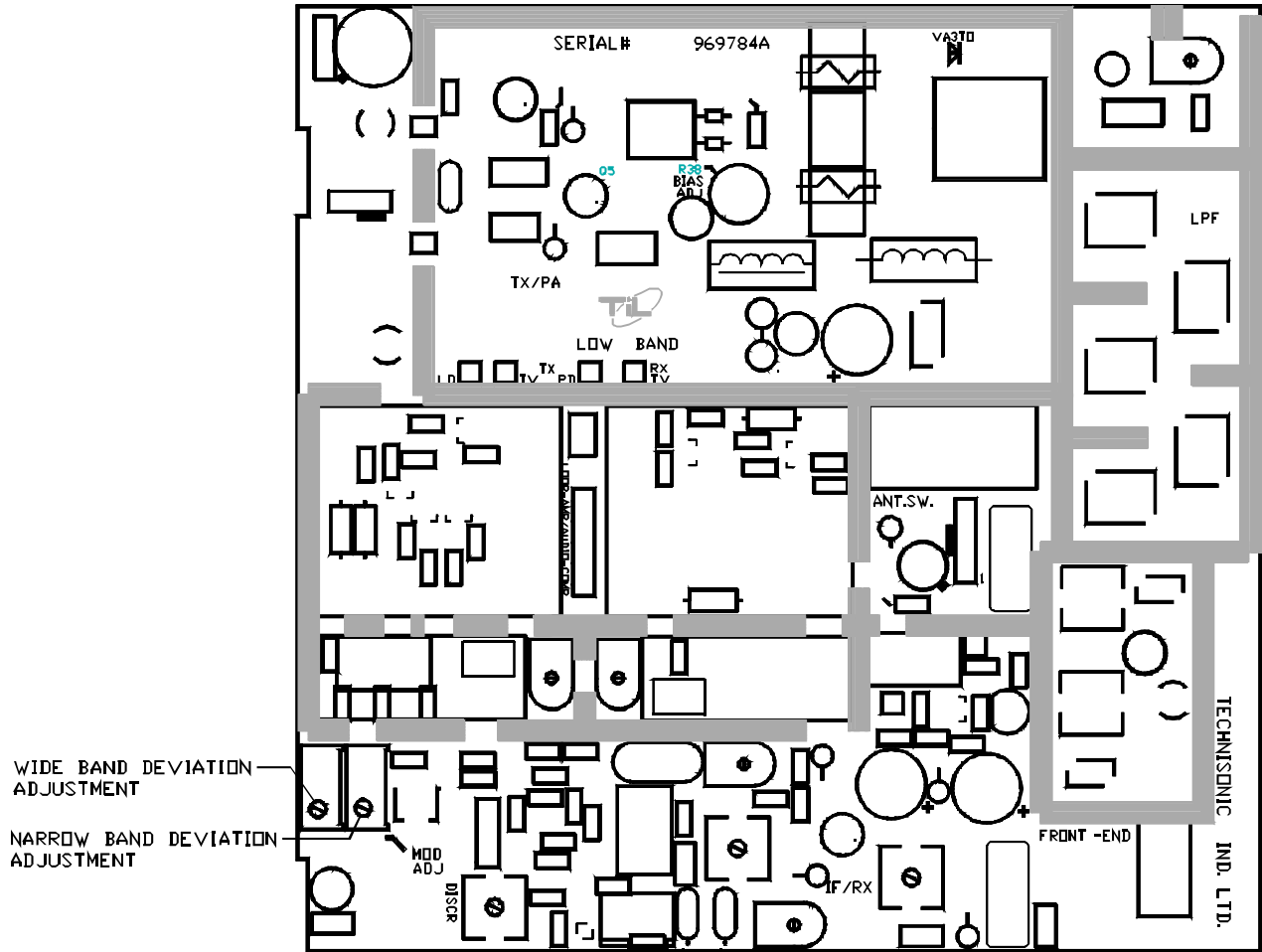

Notes: R21 is for 25 kHz (wideband) Deviation Adjustment
R16 is for 12.5 kHz (narrowband) Deviaton Adjustment

FIGURE 3.6 VLO Deviation Adjustment Potentiometer Location

APPENDIX - POST INSTALLATION EMI TEST

PURPOSE

The purpose of this test is to identify any interference that the TFM-566 may cause with existing aircraft systems. As the TFM-566 installation may include the ATC-550 antenna tuner controller, this test, as required, will also identify any interference caused by the ATC-550.

TEST CONDITIONS

The TFM-566 transceiver and any accessories (e.g. ATC-550) should be installed and function tested. The antenna VSWR should be checked. A forward/reverse power check with a in-line wattmeter should show no more than 10% reflected power. For the following tests, insure that the power switch is in the high position.

METHODOLOGY

Most of the EMI tests can be accomplished on the ground. In some cases flight testing is required or is easier. If the aircraft is approved for IFR operations, then it is mandatory that interference between the TFM-566 Airborne FM and the approach aids be checked in flight.

The GPS should be operational and navigating with at least the minimum compliment of satellites. The VHF comm should be set to the frequencies indicated with the squelch open. VOR/DME receivers should be set to the frequencies indicated and selected for display. If possible, set up a DME ramp test set on the frequencies indicated and adjust the output until the flags are out of view. The transponder and encoder should be monitored with ramp test equipment. Set the output of the transponder test set to 3db above the output necessary to achieve 90% reply. If possible set the ADF to a nearby navigation station.

Modulate the TFM-566 transmitter on the indicated frequencies for at least 20 seconds.

Observe the GPS for any degradation in satellite status or availability or flags. Listen for any noise or detected audio signals on the VHF comm(s). Listen for any noise or detected audio signals on the VOR/LOC receiver audio; look for any moment of flags or needles on the VOR/LOC/GS navigation display(s). Observe the transponder for any loss of reply or spurious reply.

List the power plant, fuel and other electric instruments in the chart provided and note any anomalies that occur while transmitting. Assess the results.

If the aircraft is equipped with an autopilot or a stability augmentation system, then test fly the aircraft and verify that operation of the TFM-566 transceiver does not have adverse effects on these systems. After checking for gross effects at a safe altitude, fly an approach with each of the different navigation systems coupled to the autopilot (ILS, GPS ETC.) and look for any anomalies.

When the installation includes the ATC-550 antenna tuner controller, this test, where indicated by an asterisk (*), will also identify any interference caused by the ATC-550. In these cases the ATC-550 must be turned on and off by means of its breaker as often as required while monitoring the victim equipment.

TECHNISONIC INDUSTRIES LIMITED

www.til.ca

RESULTS

If the installed system passes all of the applicable EMI tests, then no further action is required. If interference is observed then the interference must be assessed against the appropriate standards of airworthiness for the system in question. For example it is permissible for a VFR certified GPS to lose navigation capability while the TFM-566 unit is transmitting, providing that it recovers properly and promptly, but it is not permissible for an IFR Approach certified GPS to be affected in the same way. A complete discussion of all the standards of airworthiness to be applied in assessing EMI effects is beyond the scope of this document.

PROCEDURE

- A. Operate the TFM-566 transmitter on the following frequency for at least 20 seconds. Observe the GPS for any degradation in satellite status or availability or flags.

FREQUENCIES	GPS #1		GPS #2	
	PASS	FAIL	PASS	FAIL
87.6850 MHz				
87.6875 MHz				
143.180 MHz				
143.1825 MHz				
157.5000 MHz				
157.5425 MHz				

NOTES:

TECHNISONIC INDUSTRIES LIMITED

www.til.ca

- B.** Determine if the image frequency for the VHF Comm falls within the range of the TFM-566. If so, select a set of frequencies that will cause the TFM-566 to be set as close as possible to the image frequency. Any one of the many possible sets will suffice. Record those values in the spaces provided in the following chart. Modulate the TFM-566 transmitter on the following frequencies for at least 20 seconds. Listen for any noise or detected audio signals on the VHF comm.

Example - Bendix/King KY 196A:

The first IF frequency is 11.4 MHz. The L.O. is above the received frequency (high side injection), therefore the image frequency is 22.8 MHz above the selected frequency. Set the KY 196A to 120.000 MHz and the TFM-566 to 142.8000 MHz.

Note: Where indicated by an asterisk (*), required action is to switch ATC-550 on and off as often as necessary.

FREQUENCIES		RESULTS	
VHF #1	TFM-566	PASS	FAIL
132.000	66.0000		
135.975	67.9875		
135.975	138.0000		
121.150	157.5000		
131.250	157.5000		
128.000	*		
Image:			

FREQUENCIES		RESULTS	
VHF #2	TFM-566	PASS	FAIL
132.000	66.0000		
135.975	67.9875		
135.975	138.0000		
121.150	157.5000		
131.250	157.5000		
128.000	*		
Image:			

NOTES:

TECHNISONIC INDUSTRIES LIMITED

www.til.ca

- C. Determine if the image frequency for the VOR/ILS Nav falls within the range of the TFM-566. If so, select two sets of frequencies that will cause the TFM-566 to be set as close as possible to the image frequency. Chose one set in the localizer frequency range, and one in the VOR frequency range. Record those values in the spaces provided in the following chart. Modulate the TFM-566 transmitter on the following frequencies for at least 20 seconds. Listen for any noise or detected audio signals on the receiver audio; look for any moment of flags or needles on the navigation display.

(Note: Where indicated by an asterisk (*), required action is to switch ATC-550 on and off as often as necessary.)

FREQUENCIES		RESULTS	
VOR/ILS #1	TFM-566	PASS	FAIL
108.000	162.0000		
108.100	162.1500		
112.000	*		
Image:			

FREQUENCIES		RESULTS	
VOR/ILS #2	TFM-566	PASS	FAIL
108.000	162.0000		
108.100	162.1500		
112.000	*		
Image:			

NOTES:

TECHNISONIC INDUSTRIES LIMITED

www.til.ca

- D. Modulate the TFM-566 transmitter on the following frequencies for at least 20 seconds. Observe the Glideslope displays. Look for any movement of flags or needles on the navigation display.

FREQUENCIES		RESULTS	
G/S #1	TFM-566	PASS	FAIL
334.7 (108.1)	66.9400		
334.7 (108.1)	83.6750		
334.7 (108.1)	167.3500		

FREQUENCIES		RESULTS	
G/S #2	TFM-566	PASS	FAIL
334.7 (108.1)	66.9400		
334.7 (108.1)	83.6750		
334.7 (108.1)	167.3500		

NOTES:

- E. Operate the TFM-566 transmitter on the following frequency for at least 20 seconds. Observe the Transponder for any spurious replies or loss of reply to test set.

FREQUENCIES	TRANSPONDER #1		TRANSPONDER #2	
TFM-566	PASS	FAIL	PASS	FAIL
85.0000 MHz				
85.8350 MHz				
171.6650 MHz				
171.6700 MHz				

NOTES:

TECHNISONIC INDUSTRIES LIMITED

www.til.ca

- F. Modulate the TFM-566 transmitter on the following frequencies for at least 20 seconds. Observe the DME displays. Look for loss of distance information on the display.

FREQUENCIES		RESULTS	
DME 1	TFM-566	PASS	FAIL
978 (108.0)	81.5000		
978 (108.0)	163.0000		
1020 (112.1)	85.0000		
1020 (112.1)	170.0000		

FREQUENCIES		RESULTS	
DME 2	TFM-566	PASS	FAIL
978 (108.0)	81.5000		
978 (108.0)	163.0000		
1020 (112.1)	85.0000		
1020 (112.1)	170.0000		

NOTES:

TECHNISONIC INDUSTRIES LIMITED

www.til.ca

- G.** While turning the ATC-550 on and off as often as required, listen for any noise or detected audio signals on the HF receiver audio.

Frequencies	RESULTS	
HF #1	PASS	FAIL
16 MHz		

Frequencies	RESULTS	
HF #2	PASS	FAIL
16 MHz		

NOTE:

For the following tests, select a frequency at the top, middle and bottom of each band of the TFM-566 transceiver.

	138 to 174 MHZ Band	66 to 88 MHZ Band
Frequency #1		
Frequency #2		
Frequency #3		

- H.** At a safe altitude engage the autopilot or stability augmentation system. Modulate the TFM-566 transmitter on the above frequencies for at least 20 seconds. Observe any effect on the autopilot or stability augmentation system.

Observations:

- I.** Perform a coupled ILS approach to the aircraft's certified limits. Modulate the TFM-566 transmitter on the above frequencies for at least 20 seconds. Observe any effect on the autopilot. Repeat for second flight director/autopilot if equipped.

Observations:

TECHNISONIC INDUSTRIES LIMITED
www.til.ca

- J. List the power plant, fuel and other electric instruments in the chart provided and note any anomalies that occur while transmitting or switching the ATC-550 on and off. Assess the results.

STEP	SYSTEM	PASS	FAIL	NOTES
1	Com 1&2 (VLO 66-88 MHz Band)			
2	Transponder & Encoder (VHF 138-174 MHz Band)			
3	ADF 1 & 2			
4	VG			
5	Glideslope 1&2 (VLO 66-88 MHz Band)			
6	VOR/LOC 1&2 (VLO 66-88 MHz Band)			
7	Directional Gyro			
8	Compass			
9	Fuel Pressure			
10	Oil Temp			

TECHNISONIC INDUSTRIES LIMITED

www.til.ca

11	Amps			
12	Bus Voltage			
13	Fuel %			
14	Nt			
15	TOT			
16	Torque %			
17	Annunciators			
18	Digital Clock			
19	Oil Pressure			

TECHNISONIC INDUSTRIES LIMITED

www.til.ca

STEP	SYSTEM	PASS	FAIL	NOTES

NOTES:

Technisonic Industries Limited
240 Traders Blvd., Mississauga, ON Canada L4Z 1W7
Tel: (905) 890-2113 Fax: (905) 890-5338

**IMPORTANT
WARRANTY**

All communication equipment manufactured by Technisonic Industries Limited is warranted to be free of defects in Material or Workmanship under normal use for a period of one year from Date of Purchase by the end user.

Warranty will only apply to equipment installed by a factory approved and/or authorized facility in accordance with Technisonic published installation instructions. Equipment falling under the following is not covered by warranty:

- equipment that has been repaired or altered in any way as to affect performance,
- equipment that has been subject to improper installation,
- equipment that has been used for purposes other than intended,
- equipment that has been involved in any accident, fire, flood, immersion or subject to any other abuse.

Expressly excluded from this warranty are changes or charges relating to the removal and re-installation of equipment from the aircraft. Technisonic will repair or replace (at Technisonic's discretion) any defective transceiver (or part thereof) found to be faulty during the Warranty Period.

Faulty equipment must be returned to Technisonic (or its authorized Warranty Depot) with transportation charges prepaid. Repaired (or replacement) equipment will be returned to the customer with collect freight charges. If the failure of a transceiver occurs within the first 30 days of service, Technisonic will return the repaired or replacement equipment prepaid.

Technisonic reserves the right to make changes in design, or additions to, or improvements in its products without obligation to install such additions and improvements in equipment previously manufactured. This Warranty is in lieu of any and all other warranties express or implied, including any warranty of merchantability or fitness, and of all other obligations or liabilities on the part of Technisonic.

This Warranty shall not be transferable or assignable to any other persons, firms or corporations.

**For warranty registration please complete the on-line
Warranty Registration Form found at www.til.ca.**

MODEL TFM-566

Airborne VHF High/Low band FM Transceiver



Technisonic VHF High/Low band FM Airborne Transceiver

The Technisonic TFM-566 airborne VHF High/Low band FM transceiver utilizes state of the art frequency synthesis techniques to provide FM communications on every currently available channel within the General Radio Service VHF/FM High Band and VHF/FM Low Band (66-88 MHz). The VHF High band module covers from 138 to 174 MHz in 2.5 KHz increments while the VHF Low band module covers from 66 to 88 MHz also in 2.5 KHz steps. Operating frequencies and other related data are presented on a 96 character, four line LED matrix display, which is available in either red or green. The TFM-566 can be installed as a single transceiver operating in VHF High or VHF Low mode through a single audio controller FM input, or can be installed as FM1 and FM2 enabling simultaneous operation on both bands. Additionally, this transceiver can operate as a cross band repeater. The cross band function is front panel controlled and requires only 2 key strokes to enable or disable. All data entry and control commands are entered via an enhanced 12 button keypad conveniently situated on the face panel.

The TFM-566 can be operated in the Direct Entry or Simplex mode by simply keying in the desired operating frequency. It can also function without restriction on any split frequency pair within either band. This unit features 400 preset memory positions (200 VHF High and 200 VHF Low) each capable of storing a receive frequency, a transmit frequency, a separate CTCSS tone for each receive and transmit frequency, an alpha numeric identifier for each channel and a DPL or DCS coded squelch identifier for each channel. The TFM-566 provides for either 25 kHz wide band or 12.5 kHz narrow band operation on any or all of its 400 preset channels. An upload/download function allows the operator to download channel information from a PC, or upload stored data from the transceiver to a PC. Supporting software is supplied with each unit. Information stored in the transceiver's memory is available for instant recall by keypad entry, or by pressing the UP or DOWN buttons which allows an operator to scroll through all preset channels. The TFM-566 transceiver features a synthesized two channel VHF High guard receiver, a DTMF encoder for signaling during transmit, and a scan function which will scan any or all of the frequencies stored in up to five scan lists. A remote control head is offered (RC-566) which provides for slaved operation of the main transceiver from a remote location, allowing for a second position in the aircraft to exercise frequency control. Both VHF High and VHF Low operating frequency as well as Guard selection and operating frequency can be controlled from the "remote" position. Active frequency is displayed on both remote and local displays.

The TFM-566 transceiver is panel mounted (Dzus) and completely self contained in a 8.0 x 3.75 x 5.75 inch chassis weighing just 5.1 pounds. Front panel controls are **VLO** for VHF Low band main channel volume; **VHF** for VHF High band main channel volume, **GUARD** for guard channel volume; a **VHF/VLo** Band transmit select switch, a **MN/GD** switch for main or guard transmitter selection; a **G1/G2** switch for guard 1 or guard 2 receive and transmit select; and a **HI/LO** switch for control of transmitter power output. Hi power is 10 Watts output, low power is 1 Watt output. This transceiver offers 28 volt DC back lighting as standard, (5 Volt AC as an option) which is controlled by the aircraft dimmer bus. Display brightness is controlled from the front panel keypad. The "remote control" function is via a separate 9 pin Cannon D submini connector located on the rear panel of the TFM-566 transceiver. External access for mic gain and sidetone level adjust provide for easy installation and setup for optimum performance. The small size and light weight (5.1 lbs., 2.4 Kg) of the TFM-566 Dual Band transceiver makes this radio ideally suited to helicopter installations. Technisonic FM radios are compliant with RTCA DO-160C categories relating to Vibration, Overpressure, Humidity, Temperature and Altitude, Magnetic Effect, Power Input, Voltage Spike, Decompression, and RF Emission (including DO-160C, Section 21, Category Z). FCC and IC approval not available on VHF Lo band.

TFM-566 General Specifications

VHF Hi Module

VHF Lo Module

Frequency Range	138.000 MHz to 174.000 Mhz	66.000 MHz to 88.000 Mhz
Tuning increments	2.5 KHz	2.5 KHz
Operating Mode	F3E simplex or semi-duplex	F3E simplex or semi-duplex
Channel spacing	12.5 KHz, 25 KHz or 30 KHz as per applicable FCC and DOC spec.	12.5 KHz, 20 KHz or 25 KHz
Memory positions	200 channels	200 channels
Dimensions	(Overall TFM-566 dual band transceiver)	Approx 8.0 in x 3.75 in x 5.75 in
Weight	5.1 Lbs (2.4 Kg) total	
Temperature range	-45°C to +70° C	-45°C to +70° C
Altitude	50,000 ft	50,000 ft
Power requirement	28 VDC±15% Receive – 1.2 amps max. 1 Watt transmit - 2.2 amps max. 10 Watts transmit – 3.4 amps max. 10 Watts Dual band transmit - 5.0 amps max.	28 VDC±15% Receive – 1.2 amps max 1 Watt transmit - 2.2 amps max. 10 Watts transmit – 3.4 amps max.
Certification	FCC and IC Type approved	FCC and IC approval not available
RTCA DO-160C Env Cat	(B2,D1)XXX(B,M,N)XXXXXXABXXXXZXXX	
Guard receiver	2 channel synthesized	2 channel synthesized
CTCSS squelch capability	encodes/decodes all 64 available tones	encodes/decodes all 64 available tones
DPL/DCS capability	All available digital squelch codes	encodes/decodes all avail digital sq codes
DTMF encoder	All standard DTMF tones supported	All standard DTMF tones supported
Audio output	500 mW into 600 Ohms	500 mW into 600 Ohms
Speaker output	2.5 Watts into 4 ohms	2.5 Watts into 4 ohms
Back lighting	28V (standard) or 5V (specify) 250mA max. @ 28V 500mA Max. @ 5V	28V (standard) or 5V (specify) 250mA max. @ 28V 500mA Max. @ 5V
Display	Green (standard), red (optional)	Green (standard), red (optional)

Minimum Performance Specifications

Main receiver

Sensitivity at 12 dB SINAD	Better than 0.35 microvolts	Better than 0.35 microvolts
Adjacent channel	-75 dB for 25 kHz, -70 dB for 12.5 kHz	-75 dB for 25 kHz, -70 dB for 12.5 kHz
Spurious attenuation	-90 dB	-90 dB
Third order intermod	-70 dB	-70 dB
Image attenuation	-80 dB	-70 dB
FM acceptance	± 6 KHz	± 6 KHz
Hum and noise	Better than 45 dB	Better than 45 dB
Audio distortion	Less than 5%	Less than 5%
Ant conducted emission	Less than -70 dBm	Less than -70 dBm

Guard receiver

2 channel Guard operates on the VHF high band. All specifications identical to main receiver.

Transmitter

RF power output	1 Watt or 10 Watts	1 Watt or 10 Watts
Output impedance	50 Ohms	50 Ohms
Maximum deviation	Limited to 2.5 kHz for 12.5 kHz channels and 5 KHz for 25 kHz & 30 kHz channels	Limited to 2.5 kHz for 12.5 kHz channels and 5 kHz for 25 kHz channels
Spurious attenuation	-90 dB below carrier level	- 90 dB below carrier level
Frequency stability	±0.00025%	±0.00025%
Microphone circuit	Carbon or equivalent	Carbon or equivalent
Sidetone output	500 mw (max) into 600 ohms	500 mw (max) into 600 ohms
Harmonic attenuation	-60 dB below carrier level	-60 dB below carrier level
FM hum and noise	-40 dB	-40 dB
Audio input	50 mV at 2.5 kHz into 200 ohm circuit for ±3.5 kHz deviation, (25 kHz mode). 50 mV AT 2.5 kHz into 200 ohm circuit for ±2.0 KHz (12.5 kHz mode), adjustable	50 mV at 2.5 kHz into 200 ohm circuit for ±3.5 kHz deviation (25 kHz mode). 50 mV AT 2.5 kHz into 200 ohm circuit for ±2.0 KHz (12.5 kHz mode), adjustable
Audio distortion	Less than 5%	Less than 5 %

Note: Specifications are subject to change without notice

DPL is a trademark of Motorola Corporation

Technisonic Industries Ltd.

240 Traders Blvd, Mississauga, Ontario L4Z 1W7 Canada
Ph: 905 890-2113 Fax: 905 890-5338 www.til.ca