



A710

Understanding ACCESS/A Audio



A711



Technisonic Industries Ltd.

240 Traders Blvd.

Mississauga, ON Canada

L4Z 1W7

☎ (905) 890-2113

✉ (905) 890-5338

www.til.ca

3rd Generation Advanced Analog Systems

Rev. 1.1 March, 2009

USERS: One ACCESS/A A710 or A711 station can support up to **6 headset positions** in an aircraft, 2 flight crew (pilot/co-pilot) with full transmit and ICS capability, and 4 passengers with radio monitor and ICS operation. Passenger operation can also be extended to 5 or 6 positions if required, simply by adding resistors.

INTERCONNECT: Unlike earlier generation designs like the KMA24, AA95, and AMS40 series, the interconnect in this system is **FULLY FLOATING**, which means that **no audio lines use the airframe ground** as an audio return, thus avoiding noise, cross-talk and unwanted signal contamination. ACCESS/A systems offer as much as **35dB of improvement** in cross-talk (rejection of unwanted signals), a very important consideration in multi-station systems. Up to 10 A71X-series stations can be used in a single network, and they can be configured to have multiple ICS (Intercom System) loops.

POWER: Headset output level is a significant problem in many applications, as flight crews are now often using inefficient helmets and earplugs. ACCESS/A systems offer the highest headset drive currently available in a panel-mounted system, 1,500mW total. This is considerably more power than earlier generation systems of 100-500mW. In addition, these systems also have a 2.5W speaker output for radio monitoring when headsets are off.

CUSTOMIZATION: Customization is always a problem in the audio world. Every ship seems to have some custom issue that needs to be addressed in the audio system. ACCESS/A systems use an easily changed backlit polycarbonate overlay inset that allows rapid customization of any panel **without costly faceplate changes**. Systems already installed can be changed at any time, and custom new installations can be made quickly with stock units and custom overlays. Faceplate lighting can be 28V or 5V, and NVG compatible lighting is available. Extensive and convenient cosmetic options are available to the installer at very low cost.

SIMULCAST: Unlike rotary control audio systems, the pushbutton design and high powered mic driver of the ACCESS/A A710 and A711 controls supports simulcast, allowing multiple radios to be used at once, often an important operational requirement.

ALERTING: The ship's audio system serves as the focal point for audible alerting signals passed to the flight crew. Earlier generation system had limited connections for this, or a few tones that could be generated. ACCESS/A systems have **true voice alerting, with 6 spoken, prioritized messages**, and the ability to record and replay incoming audio. In addition, a direct headset alerting connection is also provided for existing shipboard systems. Alert messages can also be recorded in any language on a custom basis.

EXPANSION: ACCESS/A controls support 7 TX positions, which can be 6 radios and a PA, or 7 transceivers. Not enough? Need more inputs? Need more variable controls? The ACCESS/A architecture has special sum node connections that allow inputs and transceivers *to be expanded indefinitely* either using ACCESS/A system elements, or your custom external wiring.



A711X Transceiver expansion unit



A775 Receiver Expansion unit

ICS LOOP CONTROL: Often, a ship has to be broken into isolated intercom circuits, such as Medevac applications, where the medical crew needs to work isolated from the flight crew. Using the ACCESS/A A770 eyebrow unit, additional receiver inputs, and full tie/split ICS loop control can be easily implemented. And in only 3 Dzus holes of panel space!



The **A770** provides additional audio inputs, ICS loop control with calling, and speaker volume. Many custom variations are possible.

EMERGENCY OPERATION: One huge benefit of analog audio systems is their implicit ability to have extensive “fail-passive” operation that permits radio operation even if there is serious internal failure, or power is lost to the box. ACCESS/A systems allow the pilot to have full control of ALL transceivers, and continued cyclic TX control even in this faulted condition or without power, a unique ACCESS/A feature. This mode can also be used to provide an isolated radio-only mode for the pilot away from the rest of the users.

INTERCONNECT: Airframe interconnect is always time consuming and irritating, but ACCESS/A systems can use the A740 interconnect patch bay to speed up harnessing, and provide for very clean cable fabrication with convenient break and test points. All the connectors in the ACCESS/A system have fully mapped interconnect that has logical pin assignments and easily followed connections.

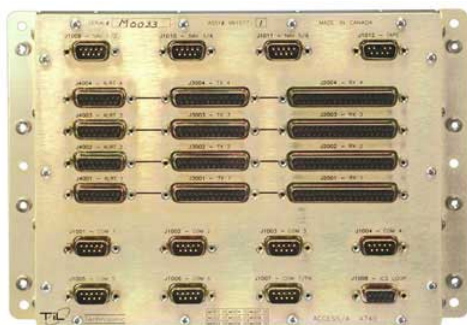

The **A740** provides a very easy way to manage complex audio installations of up to 4 stations.

ACCESS/A™ EXPANSION PANEL MODELS: A710X & A711X

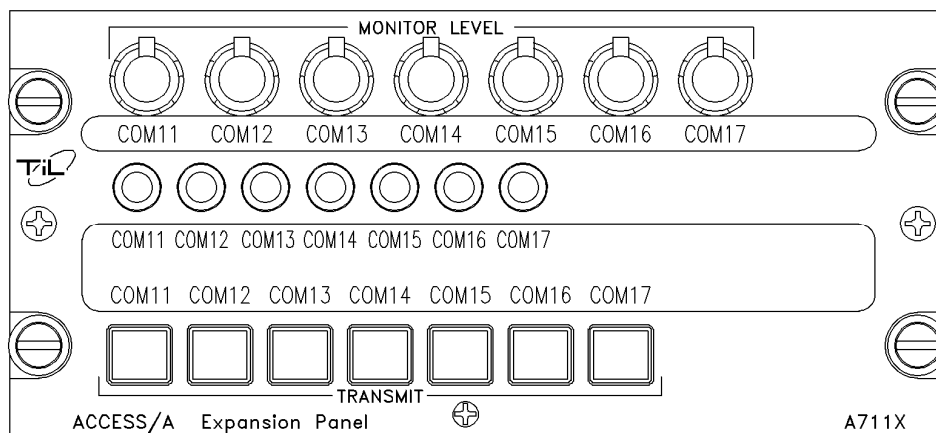
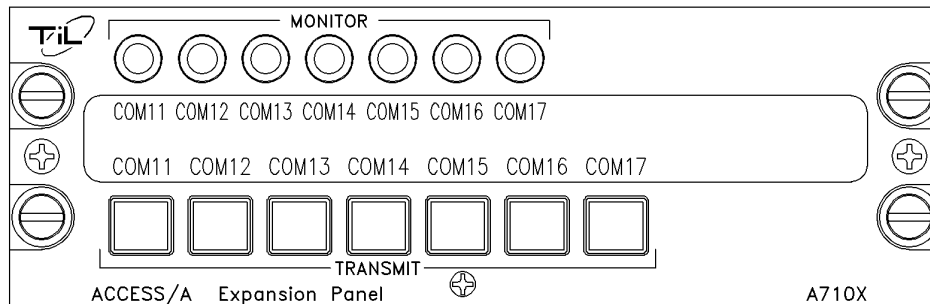

Installation and Operating Instructions

TiL Document No.
06RE387 rev-C

May 2012

Technisonic Industries Limited

240 Traders Blvd., Mississauga, Ontario L4Z 1W7 Tel:(905)890-2113 Fax:(905)890-5338
www.til.ca

REVISIONS				
Revision	Page	Description	Date	Edited by
A	1-2	compliance reference changed from TSO-C50c to TSO-C139	Jun 21 2007	RKD
B	iii	Added TSO installation notification	Nov. 11/10	RD
C	all ii	Update revision version to match. Change label from "Approved" to "Edited by"	May 8 2012	RKD

 **WARRANTY INFORMATION**

The Models A710X and A711X Audio Expansion Panels are under warranty for one year from date of purchase. Failed units caused by defective parts or workmanship should be returned for warranty service to:

Technisonic Industries Limited
240 Traders Blvd. E.,
Mississauga, Ontario L4Z 1W7

Tel: (905) 890-2113
Fax: (905) 890-5338

Technisonic Industries Limited
3840 East Robinson Road, Suite 214
Amherst, New York 14228

Tel: (716) 691-0669

 **TRADEMARK INFORMATION**

ACCESS/A, ACCESS/D, ACCESS/R & ACCESS/F are all trademarks of Technisonic Industries Ltd. and Sphere Research Corporation. All rights reserved.

 **TSO INSTALLATION NOTIFICATION**

The conditions and tests required for TSO approval of this article are minimum performance standards. It is the responsibility of those installing this article either on or within a specific type or class of aircraft to determine that the aircraft installation conditions are within TSO standards. TSO articles must have separate approval for installation in an aircraft. The article may be installed only if performed under 14CFR part 43 or the applicable airworthiness requirements.

TABLE OF CONTENTS

SECTION 1 GENERAL DESCRIPTION

1.1	Introduction	1-1
1.2	Description	1-1
1.3	Purpose of Equipment	1-2
1.4	Model Variation	1-2
1.5	Technical Summary	1-5
1.6	System Limitations	1-7

SECTION 2 INSTALLATION INSTRUCTIONS

2.1	General	2-1
2.2	Equipment Packaging Log	2-1
2.3	Wiring Requirements	2-1
2.4	Expansion Panel Installation & Drawings	2-1
	Cable Clearance	2-2
	Panel Modifications	2-2
	Shield Grounds	2-2
	Internal Options	2-2
2.5	Installation Kit Contents	2-8
2.6	Pin Locations and Connections	2-9
2.7	Main Power	2-11
2.8	Backlighting Power	2-11
2.9	Ground	2-11
2.10	Storage	2-11
2.11	Post Installation Adjustments.....	2-11

SECTION 3 OPERATION

3.1	Front Panel Operator's Switches & Controls	3-1
3.1.1	RX or Receive Selectors	3-2
3.1.2	TX or Transceiver Selectors	3-2
3.1.3	A711X RX Monitor Level Controls	3-3
3.2	Special Signal Considerations	3-4
3.2.1	Sum Node	3-4
3.3	Changing Overlay Lighting & Radio Legends	3-5

LIST OF TABLES

1-1	A710X General Specifications	1-5
1-2	A711X General Specifications	1-6

LIST OF ILLUSTRATIONS

1-1	A710X Expansion Panel - General View	1-3
1-2	A711X Expansion Panel - General View	1-4
2-1A	A710X Outline Drawing	2-3
2-1B	A711X Outline Drawing	2-4
2-2	System Installation Drawings- COM11 – COM14 Wiring	2-5
2-3	System Installation Drawings- COM15 – COM14 Wiring	2-6
2-4	System Installation Drawings- Power & System Interconnect Wiring	2-7
3-1	Front Panel Operators Switches and Controls	3-1
3-2	RX & TX Selectors	3-2
3-3	A711X RX Monitor Level Controls	3-3
3-4	Overlay & Legend Insert	3-5
3-5	Removing the Entire Overlay Assembly	3-5

SECTION 1

GENERAL DESCRIPTION

1.1 INTRODUCTION

This publication provides operating and installation information on the Model **A710X and A711X, ACCESS/A** Audio Expansion Panels manufactured by Technisonic Industries Limited. These units are designed to provide six additional communications channels to either the Model **A710 or A711 ACCESS/A** audio controllers. The **A710X** unit may be directly interchanged with an **A711X** in the same harness, but the units are *physically different in size*, and the A711X has individual volume controls for the receiver monitor levels.

1.2 DESCRIPTION

The **A710X** and **A711X** Audio Expansion Panels are designed to provide additional communications channels to an existing ACCESS/A A710 or A711 Audio Controller. Seven transceivers can be connected to the expansion panel and selected in the same manner as a standard A710 or A711 audio controller.

The Expansion Panel is connected to an A710 or A711 controller via one of its com channels; typically in the COM-7 position. This will reduce the maximum number of transceivers that an A710 or A711 can directly access from seven to six.

Push-button transmit selector switches allow immediate selection of any of the seven supported aircraft communications transceivers or PA amplifiers, while additional push-button audio input selector switches allow receive monitoring of any or all of the supported transceivers.

Both the **A711X** and **A710X** route audio internally through passive components and are not dependant on aircraft system power. A dedicated Emergency Switch is therefore not required and thus is not incorporated within these units. If power is lost to the Expansion Panel it will continue to function normally but with the following exception. The front panel status LEDs and backlighting will not be functioning.

1.3 PURPOSE OF THE EQUIPMENT

The **A710 and A711 ACCESS/A** Audio Controllers are able to directly access a maximum of seven transceivers. Connecting an A710X or A711X Expansion Panel to the ACCESS/A controller will increase this capability to a maximum of thirteen transceivers.

These units have been packaged to minimize size and weight characteristics and are ideally suited for helicopter installations, or any other Dzus rail panel location. Both the A710X and A711X meet all of the current requirements of US Forest Service "contractor furnished avionics" and can be used in a dual control installation in conjunction with a TiL FM airborne transceiver to comply with all US Forest Service Contract Requirements. The A710X and A711X are compliant with **TSO-C139**. The units meet **RTCA/DO-214** and **RTCA/DO-160C** applicable categories with the exception of the RF Susceptibility Test, which is based upon the requirements of **RTCA/DO-160A**, and the Lightning Induced Transient Susceptibility Test which is not called out under **RTCA/DO-170**.

1.4 MODEL VARIATION

The A710 and A711 come in two basic lighting configurations. A +28VDC panel lighting version and a +5VDC panel lighting version. Operationally the two are identical. The color of the solid-state backlighting is green-yellow, at approximately 565nm wavelength. Panel front color is matte black. The default configuration is with 28VDC backlighting. See the ACCESS/A price list for model numbers and availability or different versions. The most common variations are summarized below:

A710X = 061248 - (dash number)

A711X = 061249 - (dash number)

Dash Numbers:

-2	Black Panel	28VDC Lighting
-4	Black Panel	5VDC Lighting

special order:

-6	Black Panel	28VDC Lighting, Night Vision
-8	Black Panel	5VDC Lighting, Night Vision

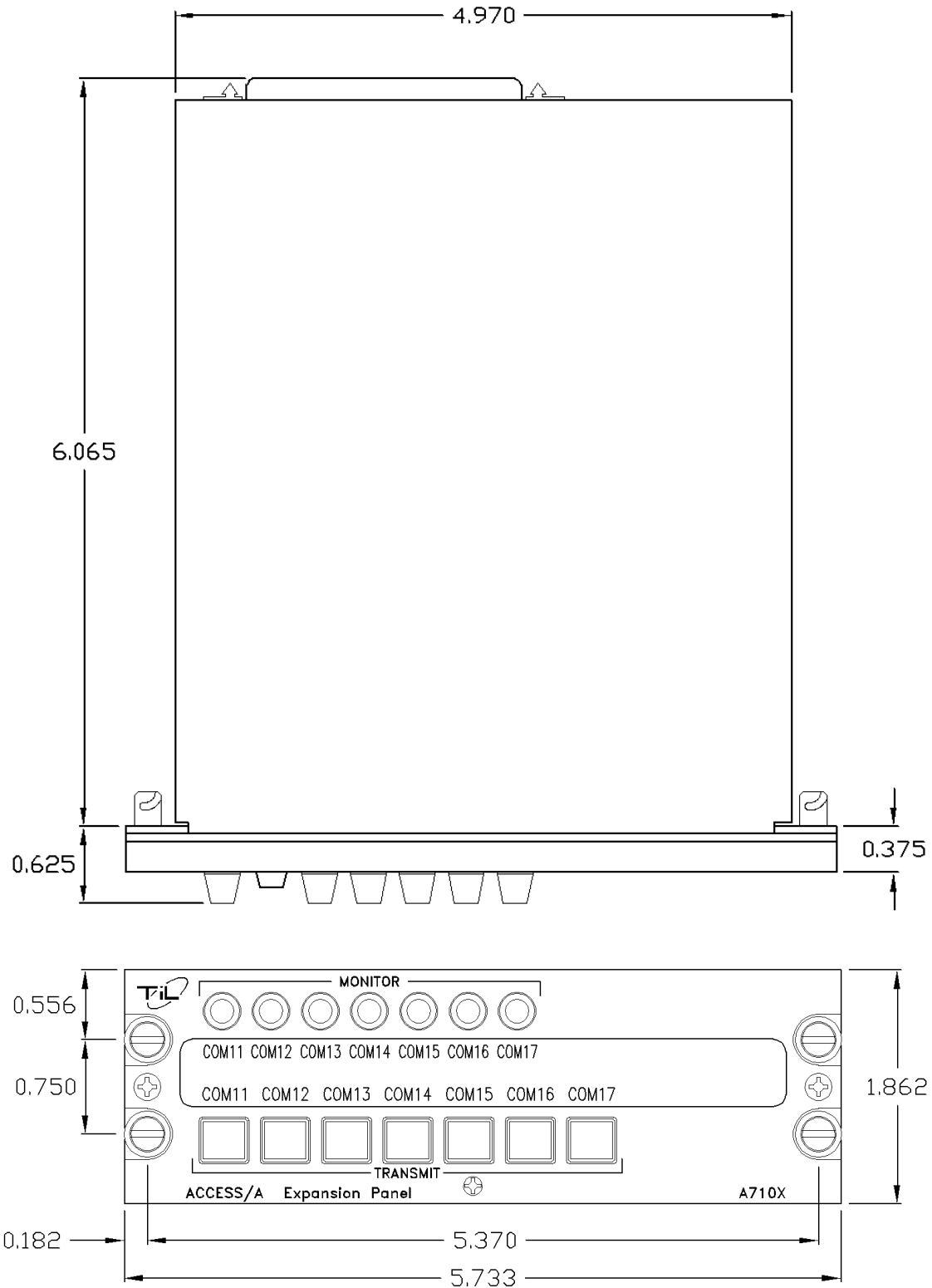

FIGURE 1-1 A710X ACCESS/A EXPANSION PANEL - GENERAL VIEW

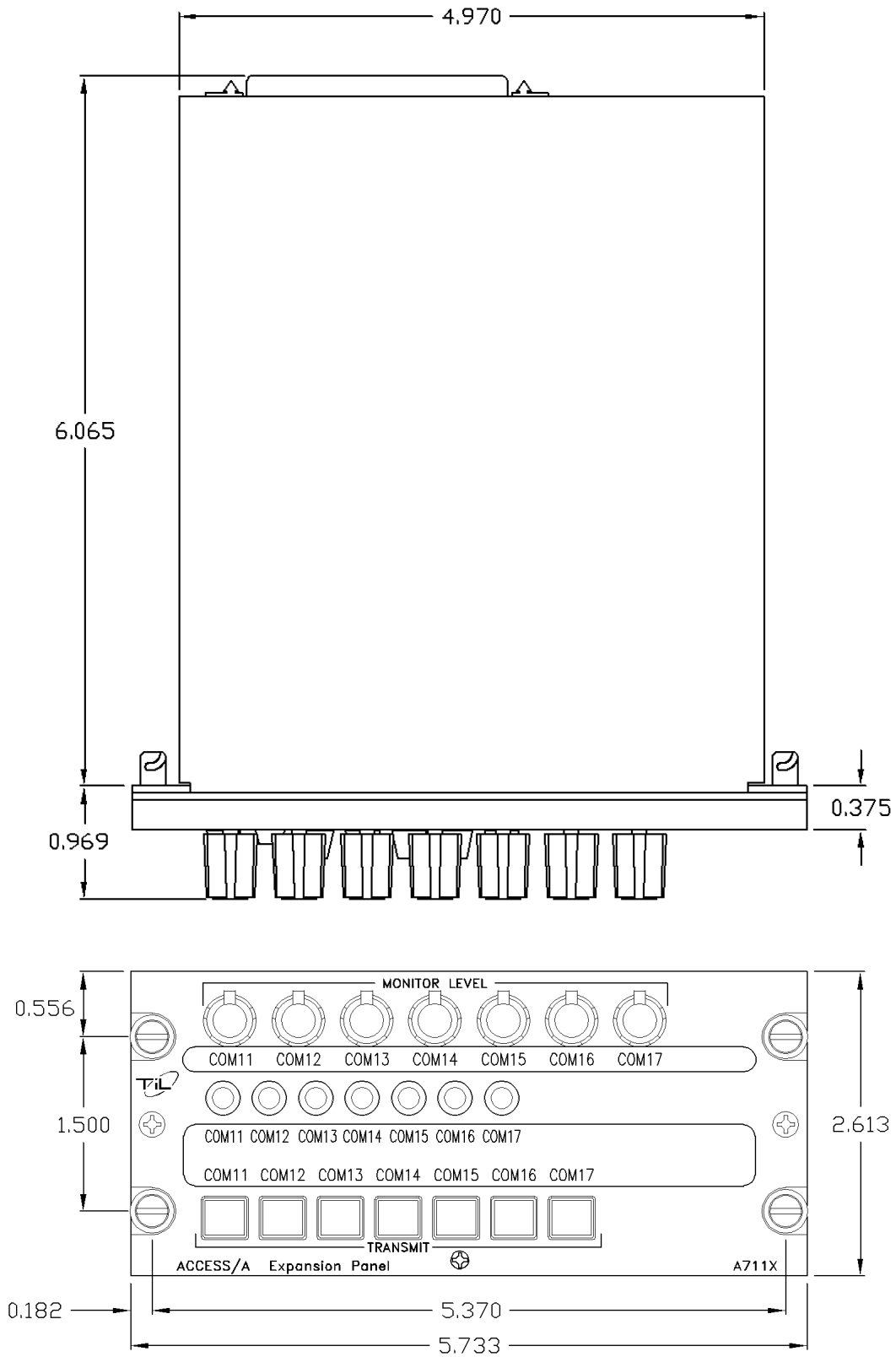

FIGURE 1-2 A711X ACCESS/A EXPANSION PANEL - GENERAL VIEW

1.5 TECHNICAL SUMMARY

A summary of the relevant electrical, operational, mechanical and physical characteristics of the expansion panels are given in **Table 1-1 and 1-2**, General Specifications.

TABLE 1-1 A710X GENERAL SPECIFICATIONS

MODEL A710X - ACCESS/A Expansion Panel:

PHYSICAL CHARACTERISTICS:

Width (max.)	5.75 inches
Height (max.)	1.875 inches
Depth	6.07 inches
Weight	1.4lbs. (0.64Kg)
Mounting	Standard Dzus, 4 fasteners

POWER SOURCE REQUIREMENTS:

DC Voltage (MIN, TYPICAL, MAX)	20.0V, 28 V, 32.2V
DC Current	20 mA
Backlighting Input:	
Standard	28 Vdc @ 50 mA
Optional	5 Vdc @ 270 mA

TECHNICAL CHARACTERISTICS:

Input Impedance (Normal Mode, any RX input)	1.55 k Ω (typical)
Input to Input isolation	better than -70 dB between inputs
Deselected input isolation	better than -65 dB

ENVIRONMENTAL:

Temperature (operating)	-45°C to +70° Celsius
Temperature (survival non-operating)	-55°C to +85° Celsius
Humidity	95% Non-condensing
Shock	12 g (any axis)
Altitude	25,000 feet

TABLE 1-2 A711X GENERAL SPECIFICATIONS

MODEL A711X - ACCESS/A Expansion Panel:

PHYSICAL CHARACTERISTICS:

Width (max.)	5.75 inches
Height (max.)	2.625 inches
Depth	6.07 inches
Weight	2.0 lbs. (0.91 Kg)
Mounting	Standard Dzus, 4 fasteners

POWER SOURCE REQUIREMENTS:

DC Voltage (MIN, TYPICAL, MAX)	20.0V, 28 V, 32.2V
DC Current	20 mA
Backlighting Input:	
Standard	28 Vdc @ 70 mA
Optional	5 Vdc @ 370 mA

TECHNICAL CHARACTERISTICS:

Input Impedance (Normal Mode, any RX input)	1.5K - 2K Ω (approx.)
Input to Input isolation	better than -70 dB between inputs
Deselected input isolation	better than -65 dB

ENVIRONMENTAL:

Temperature (operating)	-45°C to +70° Celsius
Temperature (survival non-operating)	-55°C to +85° Celsius
Humidity	95% Non-condensing
Shock	12 g (any axis)
Altitude	25,000 feet

1.6 SYSTEM LIMITATIONS

A summary of the relevant system limitations is given below.

Induced Signal Susceptibility, RF Susceptibility and RF Emission

The wiring connections called out in the Installation and Operating Instructions, chapter 2, describes shield terminations for minimum ground loop noise. The test harnesses used for RTCA/DO-160 sections 19, 20, and 21 – Induced Signal Susceptibility, RF Susceptibility, and Emission of RF Energy respectively - used shield terminations at both ends of the cable. Should RF susceptibility pose a problem in a particular installation the installer may wish to try terminating shields at both ends of the cable, further, if this does not produce satisfactory results then double shielding may be required.

SECTION 2

INSTALLATION INSTRUCTIONS

2.1 GENERAL

This section contains information and instructions for the correct installation of the **A710X and A711X, ACCESS/A** Expansion Panels.

Make certain that the unit is correctly operating in accordance with the equipment user's requirements and manufacturer's specifications, prior to releasing the equipment for service.

2.2 EQUIPMENT PACKING LOG

Unpack the equipment and check for any damage that may have occurred during transit. Save the original shipping container for returns due to damage or warranty claims. Check that each item on the packing slip has been shipped in the container. Verify that the equipment's backlighting configuration is the **same as that required**.

2.3 WIRING REQUIREMENTS

Airframe wiring should be single conductor in accordance with MIL-W-22759 or multi-conductor in accordance with MIL-C-27500 or Raychem 44 (81044) or 55 single or multi-conductor and shielded wire. Heatshrink solder sleeves (such as Raychem or equivalent) should be utilized for shield termination.

All audio input and output line connections should be made with 2 conductor/twisted pair shielded cables as illustrated. The power and ground lines should be a minimum of #24 AWG (#22 preferred). Keying lines may be #24 AWG or larger.

CAUTIONS:

DO NOT bundle *any low level audio lines with RF coaxial cables, 60 Hz or 400Hz AC inverter, motor, pump or blower wiring*, which can cause noise coupling between the various systems, especially during RF transmission or pump/blower mechanical operation. Maintain as much distance as possible from these types of wire bundles.

Note that there is really **no effective field-installable shielding for magnetic coupling** (which occurs at high currents), and the only suitable prevention for this type of interference is **distance** between the interfering lines. Shielded wiring is effective **only** for electrostatic coupling, or voltage driven interference.

2.4 ACCESS/A EXPANSION PANEL INSTALLATION

The **A710X and A711X ACCESS/A** Audio Expansion Panels are designed to be Dzus mounted and should be installed in conjunction with an **IN-A710X** installation connector kit. See **Figure 2-1** for an outline drawing of the units with dimensions, to facilitate the installation.

☑ CABLE CLEARANCE:

Allow **at least 2.5" of additional rear clearance** for mating connectors and hoods (side routing), or 3.0" (back routing). Cables should be long enough to **permit the unit to be removed** from the panel, and the connectors to be easily disengaged. **DO NOT** dress or strap the mating cables so that front removal is impossible, or the unit cannot be removed for service in the field.

☑ PANEL MODIFICATIONS:

Modified panel legends, panel lighting, NVG compatibility, or overlay colors are also possible, please see the price list for a full summary of options and part numbers. Overlays and legends may be easily changed at low cost in the field with no special tools or service facilities required.

☑ SHIELD GROUNDS:

Convenient **shield ground connections** are provided at each connector for the indicated input signal shield drains, and will give the shortest possible return for these lines. These shield lines may be daisy chained together, and a single wire from each cable brought out to the connector pin .

☑ INTERNAL OPTIONS:

The A711X RX Monitor Level Controls have an adjustment range that normally go to approximately 2-5% level at minimum setting (not off). This range can be reduced to zero by installing optional internal jumpers.

The A710X does not have any configurable internal options.

DRAWINGS:

A full **ACCESS/A** Expansion Panel installation example is given in the multi-page sections of **Figure 2-x**. These installation and mechanical drawings are available as **AutoCAD files** ("DWG"/R12 format, Windows Metafile "WMF" or "DXF" format) free of charge to authorized TiL dealers and completion centers.

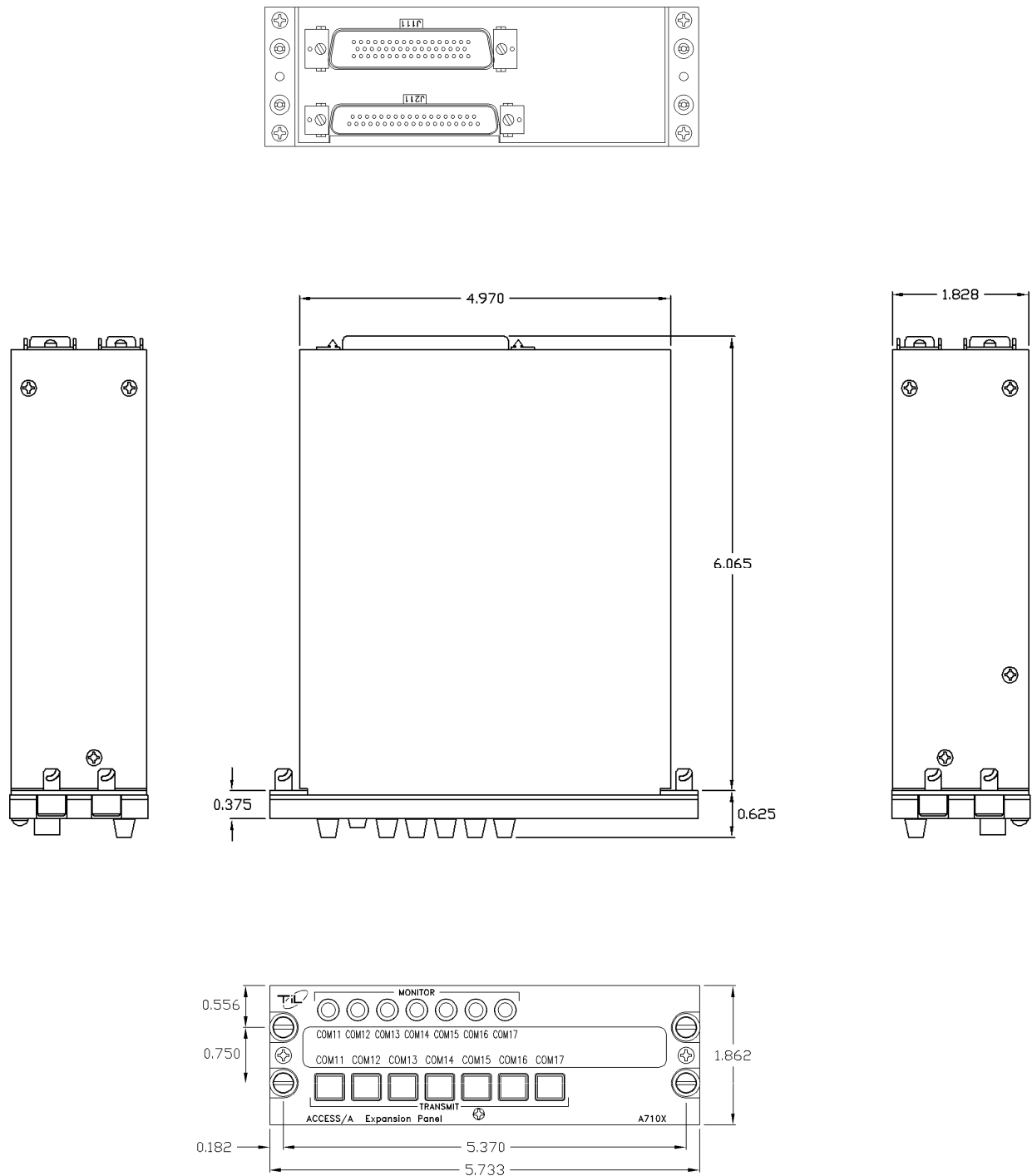

FIGURE 2-1A Outline Drawing for Model A710X ACCESS/A Expansion Panel

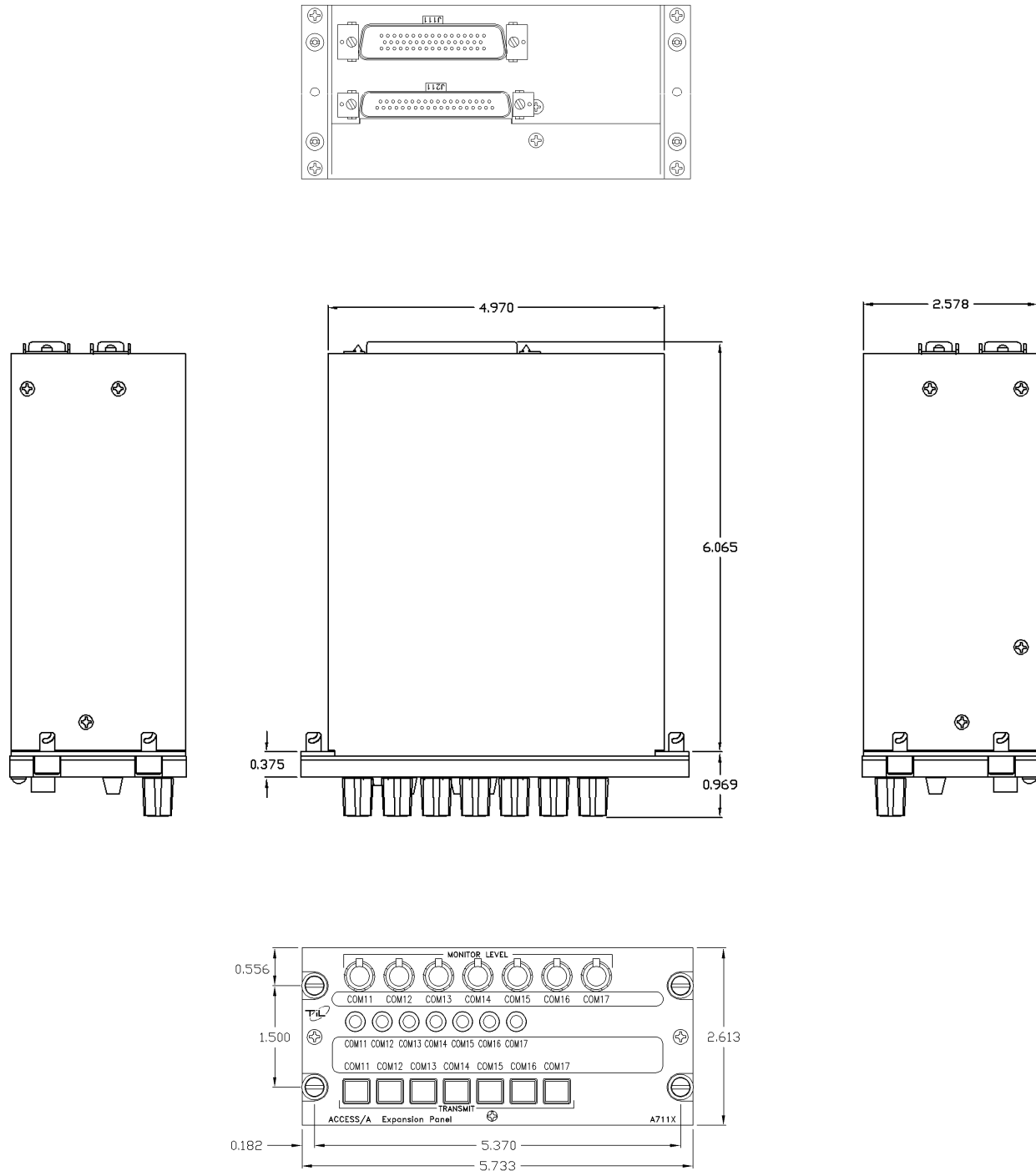
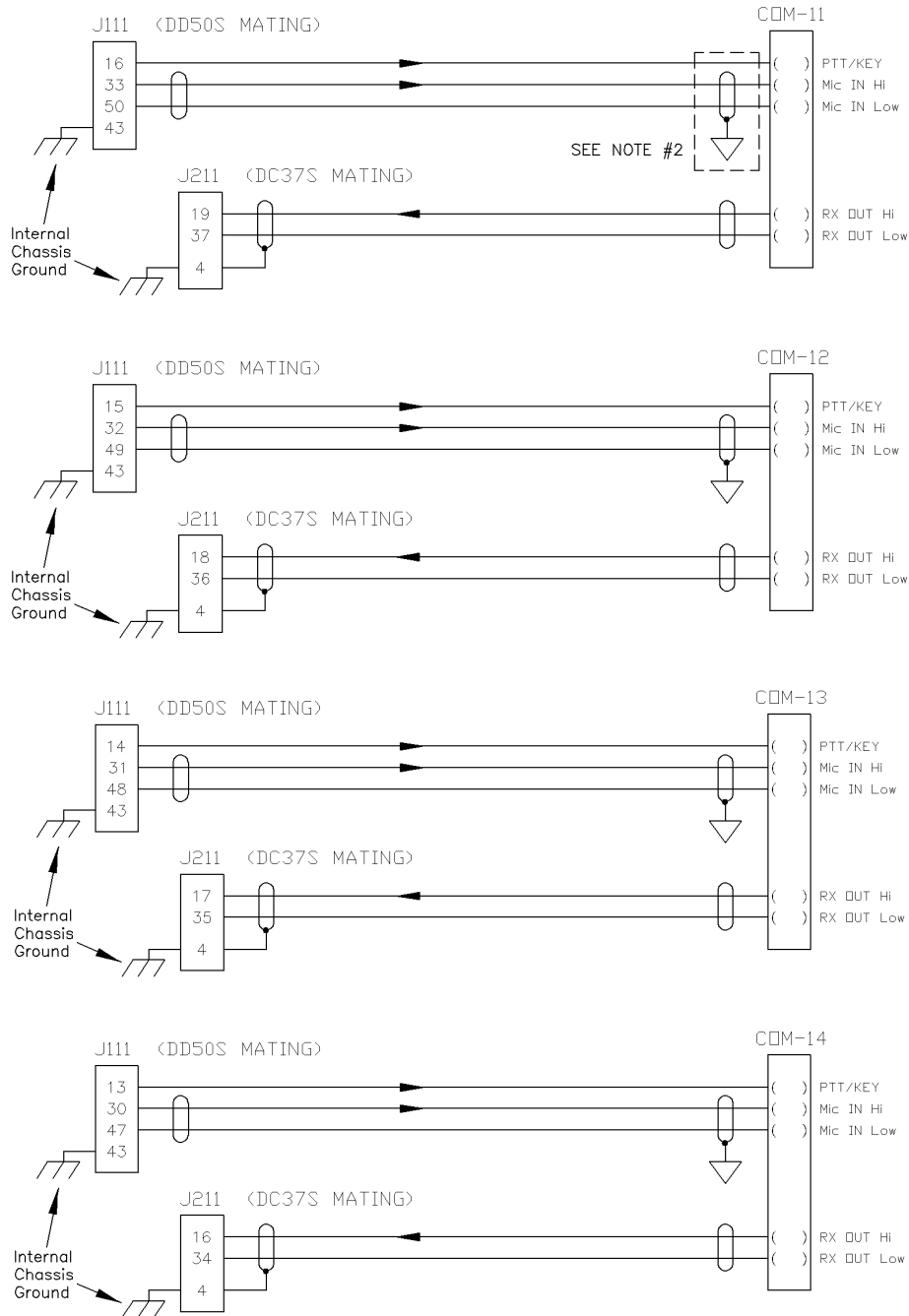
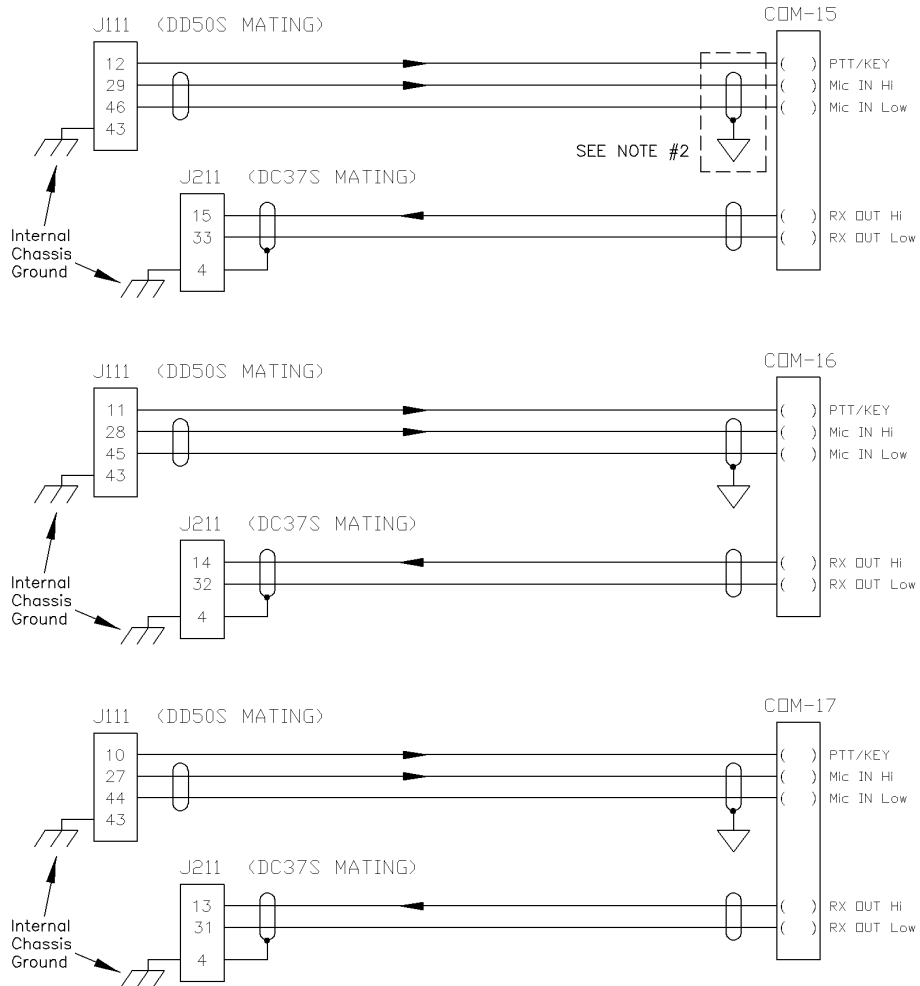

FIGURE 2-1B Outline Drawing for Model A711X ACCESS/A Expansion Panel



- Shields are grounded as required at either end of the cables. Do not ground both ends of a shield.
- Mic/Key/Lo lines may be run as a 3-cond. shielded wire in noisy environments for better RF rejection.

Figure 2-2 COM11 - COM14 WIRING



- Shields are grounded as required at either end of the cables. Do not ground both ends of a shield.
- Mic/Key/Lo lines may be run as a 3-cond. shielded wire in noisy environments for better RF rejection.

Figure 2.3 COM15 – COM17 WIRING

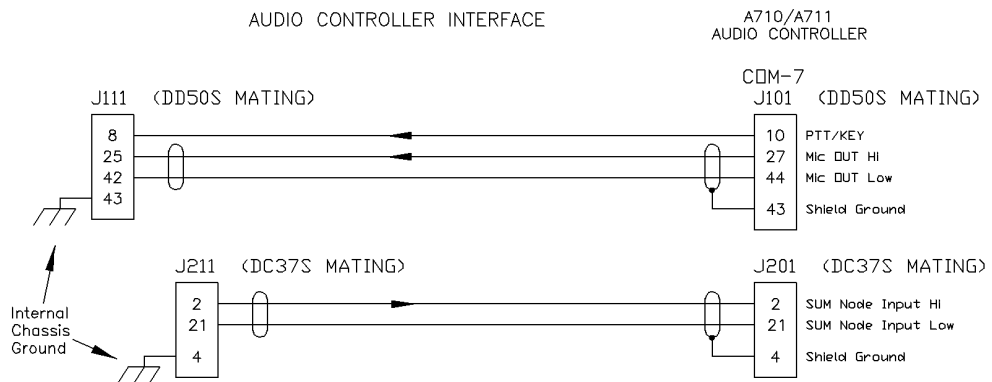
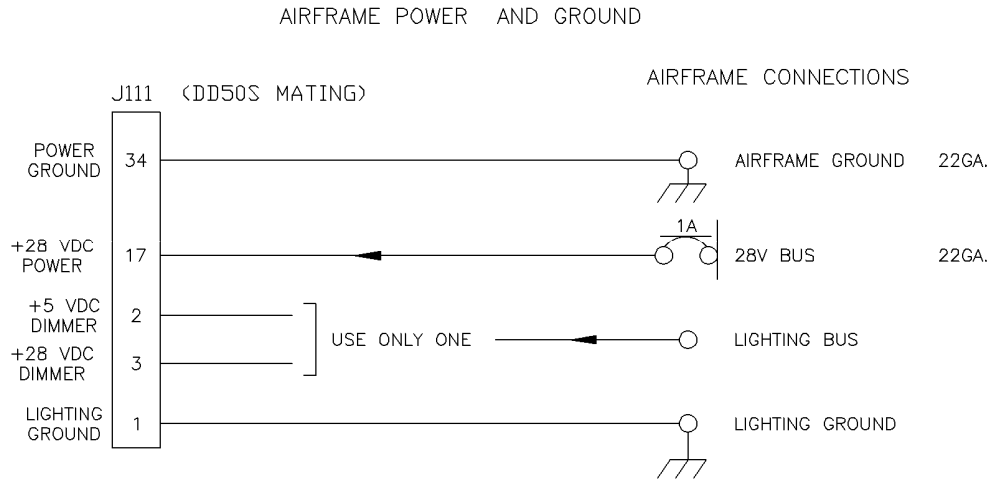

- Shields are grounded as required at either end of the cables. Do not ground both ends of a shield.
- Mic/Key/Lo lines may be run as a 3-cond. shielded wire in noisy environments for better RF rejection.

Figure 2-4 POWER & SYSTEM INTERCONNECT WIRING

2.5 INSTALLATION KIT - CONTENTS

The **IN-A710X** installation kit (used for both **A710X** & **A711X** units) consists of:

1. One **50 pin female** D-subminiature mating connector complete with crimp pins, V-locks and hood. (DD50S) **P101**
Positronics p/n SD50F00JVLX + 50ea. FC7520D contacts
2. One **37 pin female** D-subminiature mating connector complete with crimp pins, V-locks and hood. (DC37S) **P201**
Positronics p/n SD37F00JVLX + 37ea. FC7520D contacts

Note: The mating connectors use a “one-hand”, tool-free Positronics V-lock assembly for ease of airframe installation and removal.

In addition, the following items **are packed with each A710X or A711X unit**:

1. This manual.
2. Warranty registration card.

2.6 INSTALLATION - PIN LOCATIONS AND CONNECTIONS

The pin numbers and locations for the connectors located on the rear of the **A710X/A711X ACCESS/A** Expansion Panel are shown in the following tables.

Bottom Connector J111 DD50P

Mating Cable Connector: **DD50S**
(50 pin Female)

J111 Connector Pin Assignments – TX Connector				
LOW	HIGH		Connection	Notes
	17		+28VDC Power In	Main Power Input
34			Power GROUND	Main Power Ground Line
1			Lighting/Dimmer Common (GND)	Dimmer Lines
	2		+5 VDC Dimmer Input	Dimmer Lines Use only one
	3		+28 VDC Dimmer Input	Dimmer Lines Use only one
COM	MIC	KEY	Connection	Notes
42	25	8	COM-X In	To Audio Panel TX COM channel
50	33	16	COM 11 TX Mic Out	Left-hand-most TX switch
49	32	15	COM 12 TX Mic Out	
48	31	14	COM 13 TX Mic Out	
47	30	13	COM 14 TX Mic Out	
46	29	12	COM 15 TX Mic Out	
45	28	11	COM 16 TX Mic Out	
44	27	10	COM 17 TX Mic Out	Right-hand-most TX switch
43			Shield Ground	

- The following pins are not used and should have no connection: 4-7, 9, 18-24, 26, 35-41.

View from solder side of DD50S MATING CONNECTOR:

1.....17
18.....33
34.....50

Top Connector J211 DC37P

Mating Cable Connector: DC37S
(37 Pin Female)

J211 Connector Pin Assignments - RX Connector			
LOW	HIGH	Connection	Notes
21	2	SUM Out	To Audio Panel RX COM channel
4		Shield ground	Shield drain for input lines.
31	13	COM 7 RX Audio	Right-hand-most TX switch.
32	14	COM 6 RX Audio	
33	15	COM 5 RX Audio	
34	16	COM 4 RX Audio	
35	17	COM 3 RX Audio	
36	18	COM 2 RX Audio	
37	19	COM 1 RX Audio	Left-hand-most TX switch

- The Common-Low lines (pins 21, 31-37) are floating above airframe ground (pin 4).
- The following pins are not used and should have no connection: 1, 3, 5-12, 20, 22-30.

View from solder side of DC37S MATING CONNECTOR:

1.....19
20.....37

2.7 MAIN POWER +28VDC

The main power +28VDC ($\pm 20\%$) is connected to pin **17** of the 50 pin (lower) "D" connector.

As previously indicated, this connection should be made with at least **#24 AWG** wire, with **#22 preferred**. If from a very noisy source, with high levels of parasitic AC, shielding may improve rejection of this coupled AC into other low level audio lines.

2.8 BACKLIGHTING POWER +28VDC / +5VDC

The backlighting power for the front panel of the **A710X and A711X** is supplied via pins **1, 2 & 3** of the 50 pin (lower) "D" connector. Unless ordered and indicated otherwise on the rear of the **ACCESS/A A710**, the unit is shipped with the +28VDC backlighting option. Note that different pins are used for 5V and 28V lighting, and there is a dedicated lighting ground pin, which **MUST** be connected for the lighting to work. Lighting is isolated from other circuits in the system for **noise reduction reasons**.

2.9 GROUND

The A710X/A711X Expansion Panel is designed for full Ground Isolation from the Airframe. This is necessary in many cases where the Airframe Ground causes significant noise in the Audio system.

Main ground (power return) to the **A710 and A711** is on pin **34** of the 50 pin "D" connector. All other groups of audio lines have their own "common" lines, which float above the airframe ground, to provide signal isolation. These common lines **MUST** be connected to the source audio, or no signal flow will result, except for stray leakage.

2.10 STORAGE

When not in use, Store the **A710X and A711X** in the original Anti-Static bag if possible, and in a non-Humid place. Optimum storage temperatures for best shelf life should not exceed +35°C, or be less than -10°C.

2.11 POST INSTALLATION ADJUSTMENTS

There are no post installation adjustments for the A710X / A711X Expansion Panels.

SECTION 3

OPERATING INSTRUCTIONS

3.1 FRONT PANEL OPERATORS SWITCHES AND CONTROLS

This section explains the operation of the **A710X & A711X ACCESS/A** Expansion Panel Controls, and how to use either system in a typical aircraft environment. Since the controls on the two units differ only in the extra receive monitor pots at the top of the **A711X**, the **A710X illustration is used for all of the explanations**, except those **specific to the A711**. All normal user controls are on the front panel of the unit and are either variable rotating controls, or selectable push-button switches.

The exact radio legends on the face of the **A710X** or **A711X** may vary from the illustration shown, due to customer specifications, and the final legend insert that is installed for the specific aircraft installation. A full view of the controls is given in **Figure 3-1**.

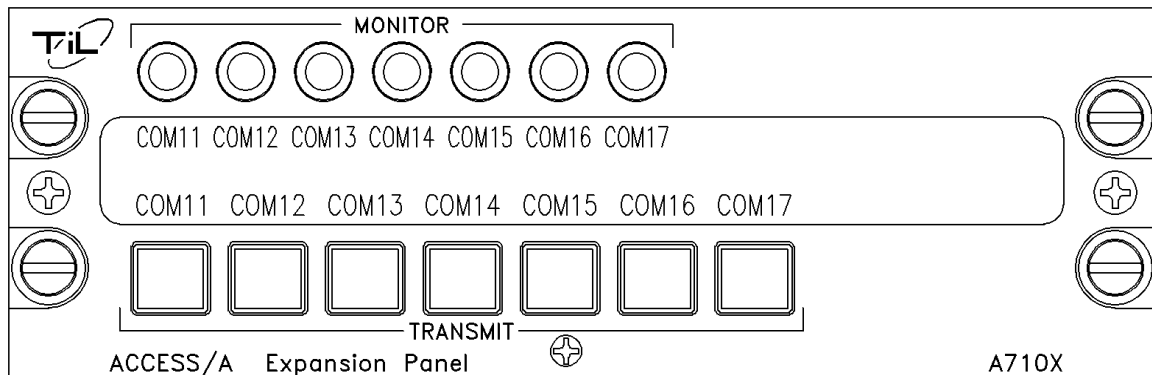

FIGURE 3-1 A710X FRONT PANEL OPERATOR'S SWITCHES AND CONTROLS

- The top row of round push-buttons selects the **RX** or **RECEIVER** audio to be sent to the crew headsets.
- The bottom row of square push-buttons selects the **TX** or **TRANSCEIVER** to be used when transmitting.
- Any combination of RX sources may be selected at one time, for system monitoring purposes.
- The corresponding RX audio of any TX selection is made **AUTOMATICALLY** whenever a TX button is depressed. This function is often referred to as Auto-RX select.

3.1.1 RX or RECEIVE SELECTORS

These 10 push-button **RX SELECTOR** switches allow the crew to monitor any combination of the Receivers in the airframe system, independent of the setting of the transceiver selectors. The **RX SELECTORS** have an alternate action, **push in** to activate the audio, **push again** to have the switch return to the **out position and off**.

Any number or combination of RX switches may be used at the same time. Note that the corresponding RX audio is always **automatically selected** by a **TX SELECTOR**, and the matching RX switch does **not** have to be selected as well

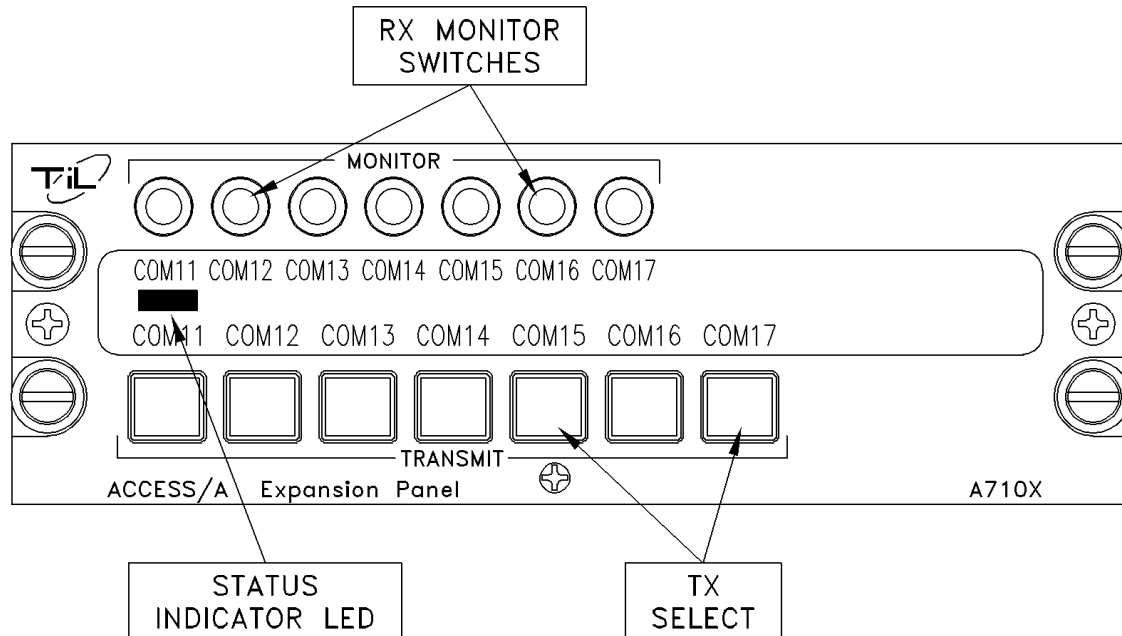

FIGURE 3-2 A710X RX & TX SELECTORS

3.1.2 TX or TRANSCIVER SELECTORS

The setting of the **TX SELECTOR** switches determines **which Transceiver will transmit** the activated microphone audio, and which receiver the system will monitor, independent of the additional RX switch settings. The buttons have an **interlocking action**, and pressing one button will **automatically de-select** any other that is already activated. If two buttons are depressed at the same time, **simulcast operation** (on two radios) is enabled.

The buttons change from **black to white when activated**, and a corresponding **STATUS LED illuminates green** above the button. If a PA is installed at the far right selector position, the button itself turns yellow to warn of potential live broadcast of audio outside the aircraft. The **LEDs turn yellow when the specific transmitter is activated by the A710X/711X**, and all the LEDs will extinguish if all transmitter buttons are returned out to the off (black) position, and no transmitter has been selected. This indicates that no valid TX mode has been selected by the crew.

3.1.3 A711X RX MONITOR LEVEL CONTROLS

The operation of the **A711X** control differs slightly from the **A710X**, in that **individual receive monitor controls** are provided to adjust the level for each of the 7 transceivers. These controls normally go to approximately 2-5% level at the minimum setting (not off), but can be strapped internally to go fully off, if required. Selecting the input "off" is normally done by the setting of the RX monitor switch, not the level control. This is a safety feature, to prevent accidental total loss of incoming communication due to an inadvertently low level pot setting.

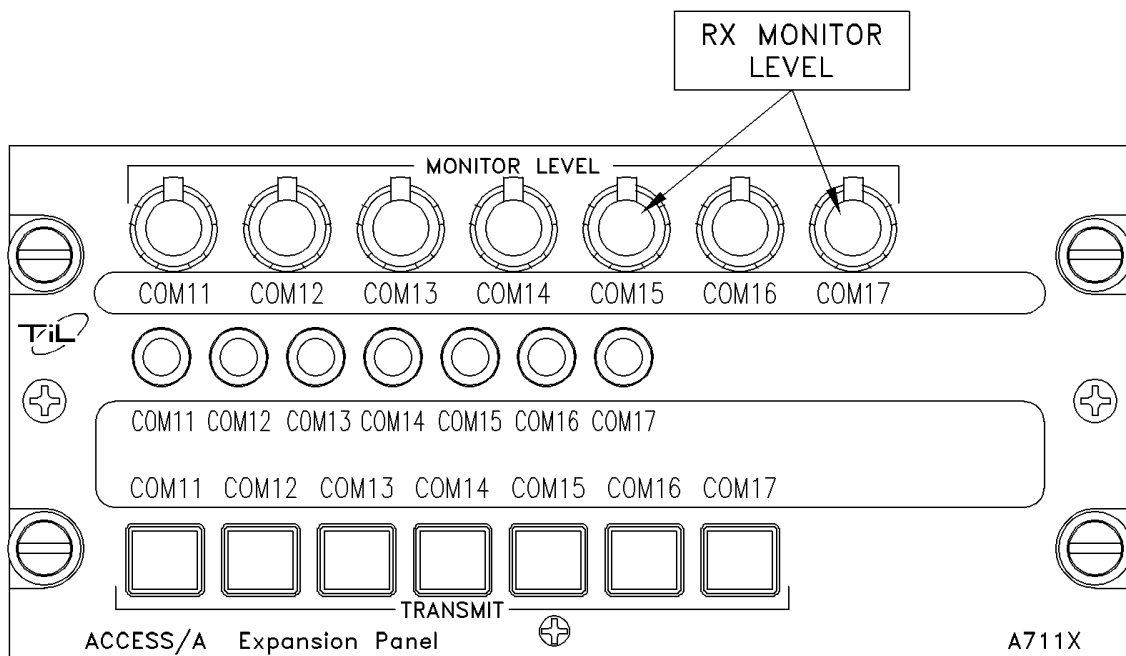

FIGURE 3-3 A711X RX MONITOR LEVEL CONTROLS

3.2 SPECIAL SIGNAL CONSIDERATIONS

There are several special signals and lines related the A710 and A711, which require careful installation planning, and understanding by the flight crew.

3.2.1 SUM NODE

This line is used to **expand the RX input bus** of the **A710/A711** control, and allows many supplemental receivers to be attached with high isolation from other signals. Use of either the A710X or A711X Expansion Panel is required to tie to this line. All radio sources monitored by the A710X or A711X are sent to the SUM Node inside a companion **A710/A711** unit. Only one station may be connected in this way, or severe cross-talk will result. Signals directed to this station input will be muted during TX operation, just as for any other RX input.

3.3 CHANGING OVERLAY LIGHTING & RADIO LEGENDS

The legends on the **A710X** and **A711X** front panels, and the overlay color and lighting type can all be easily changed in the field to suit special requirements. The entire lighted overlay is changed by removing three screws, as illustrated below. Remove the knobs (use a 0.050" Allen/Hex key to undo the set screws), and the overlay assembly will pull off. A small polarized square plug on the rear mates with the lighting assembly, and can be pulled off to allow the overlay to be completely removed and exchanged. If the lighting **VOLTAGE** is changed, the overlay must also be changed. See the service manual for details.

The legend insert is adhesive, and can be removed by lifting a corner free with a sharp X-acto knife blade, and then gently pulling the entire Lexan strip free. Remove the backing from a new legend strip (with the desired legends), line it up evenly, and press it into place on the overlay recess. The adhesive will cure fully in 48 hours. Be sure any bubbles are pressed out, and that all edges are firmly attached.

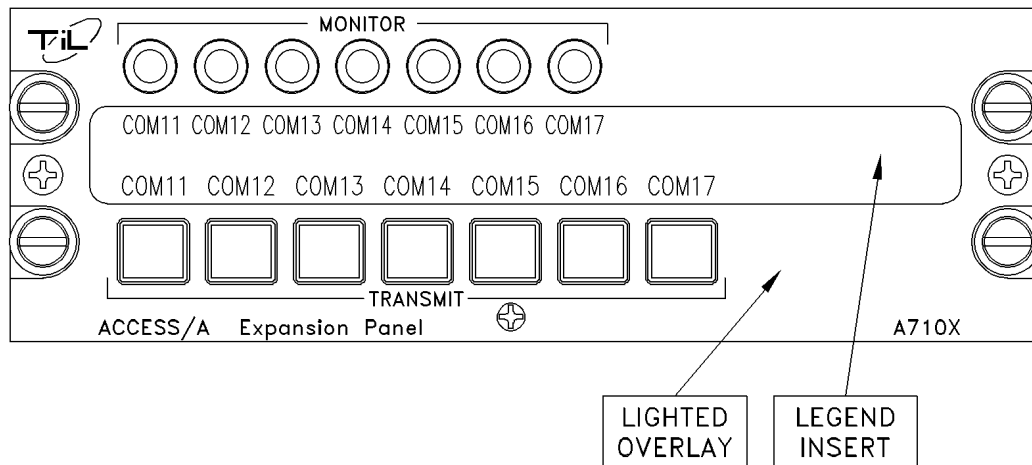

FIGURE 3-4 OVERLAY & LEGEND INSERT

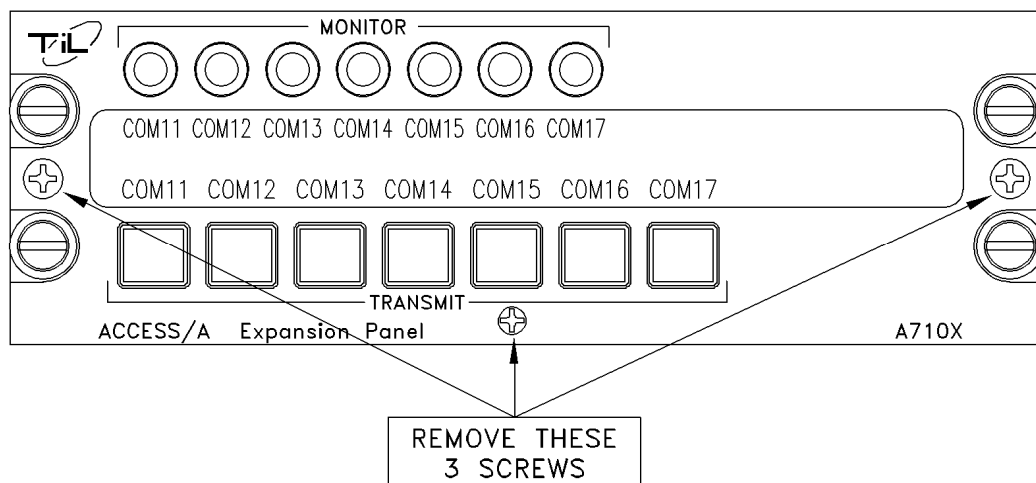

FIGURE 3-5 REMOVING THE ENTIRE OVERLAY ASSEMBLY