



# VHF/AM MOBILE TRANSCEIVER

## Model TiL-90-6R

MOBILE SYSTEM P/N 860605  
(TMS-100)



## Installation and Operating Instructions

TiL Document No. 89RE190  
Rev. F

JULY 2012

---

### Technisonic Industries Limited

240 Traders Boulevard, Mississauga, Ontario L4Z 1W7  
Tel: (905) 890-2113 Fax: (905) 890-5338  
[www.til.ca](http://www.til.ca)

---

Copyright by Technisonic Industries Limited. All rights reserved.



**REVISION HISTORY**  
[ 89RE190 ]

REV	SECTION - PAGE -	DESCRIPTION	DATE	Edited by
n/c		Original Document		
A				
B				
C				
D				
E	Global	New Document Template (new file format) Title page changed, Headers/Footers added Added Revision page, Added Warranty page		
	2-2	Added <u>note</u> to §2.4 Channel Freq. Selection referring to units built after Jan 2012 with a USB port and added <u>Appendix A</u> (TDP-90 for USB AM units) with Installation and Operating Instructions.	DEC 2011	FM
F	Title Pg iii	Simplify System description Updated FCC information including antenna and Simplify description under "Warning"		
	1-8	Revise Transmitter Characteristics for FCC and ICAN information		
	2-2 2-1 Appendix A	Removed note that was added on pg 2-2 then moved and updated to para 2.1 re: TDP-90. Updated TDP-90 to REV A	JULY 2012	FM



## **WARNING**

Do not make physical contact with antenna when transmitter is on.

## **CAUTION ! STATIC SENSITIVE !**



This unit contains static sensitive devices. Wear a grounded wrist strap and/or conductive gloves when handling printed circuit boards.

## **FCC COMPLIANCE INFORMATION**

This device complies with Part 15 of the FCC Rules. Operation is subject to the following two conditions: (1) this device may not cause harmful interference and (2) this device must accept any interference received, including interference that may cause undesired operation.



**WARNING:** For compliance with FCC RF Exposure Requirements the mobile transmitter antenna installation shall comply with the following two conditions:

1. The transmitter antenna gain shall not exceed 3 dBi.
2. The transmitter antenna is required to be located outside of a vehicle and kept at a separation distance of 90 cm or more between the transmitter antenna of this device and person(s) during operation.

**NOTE:** This equipment has been tested and found to comply with the limits for a Class A digital device, pursuant to Part 15 of the FCC Rules. These limits are designed to provide reasonable protection against harmful interference when the equipment is operated in a commercial environment. This equipment generates, uses, and can radiate radio frequency energy and, if not installed and used in accordance with the instruction manual, may cause harmful interference to radio communications. Operation of this equipment in a residential area is likely to cause harmful interference, in which case the user will be required to correct the interference at his/her own expense.

**FCC LABELING INFORMATION:** When this device is permanently mounted in an enclosure where the FCC ID label can not be seen, another label must be placed on the outside of the enclosure stating 'contains FCC ID: IMA90-6R'.

## **WARRANTY INFORMATION**

The TMS-100 Mobile System is under warranty for one year from date of purchase. Failed units caused by defective parts, or workmanship should be returned to:

Technisonic Industries Limited  
240 Traders Boulevard  
Mississauga, Ontario L4Z 1W7

Tel: (905) 890-2113  
Fax: (905) 890-5338



**TABLE OF CONTENTS**

SECTION	TITLE	PAGE
<b>SECTION 1 GENERAL DESCRIPTION</b>		
1.1	INTRODUCTION .....	1-1
1.1.1	Purpose of the System .....	1-1
1.1.2	Modes of Operation .....	1-2
1.2	TECHNICAL SUMMARY .....	1-8
<b>SECTION 2 CHANNEL FREQUENCY SELECTION AND INSTALLATION</b>		
2.1	INTRODUCTION .....	2-1
2.2	FREQUENCY RANGE .....	2-1
2.3	PREPARATION .....	2-1
2.4	PRE-PROGRAMMING OF CHANNEL FREQUENCY .....	2-2
2.4.1	Frequency Selection MHz .....	2-2
2.4.2	Frequency Selection kHz .....	2-2
2.4.3	Installation of Diodes .....	2-2
2.5	INSTALLATION OF MODULE A5 .....	2-5
2.6	OPERATIONAL CHECK .....	2-5
2.7	INSTALLATION - INTRODUCTION .....	2-5
2.8	TRANSCEIVER LOCATION .....	2-5
2.9	VEHICLE POWER SUPPLY .....	2-5
2.10	POWER INPUT CABLE ASSEMBLY .....	2-7
2.11	ANTENNA ASSEMBLY .....	2-7
2.12.1	Antenna Location .....	2-7
2.12.2	Antenna Installation .....	2-7
2.13	MOUNTING BRACKET INSTALLATION .....	2-7
2.14	TRANSCEIVER INSTALLATION .....	2-7
2.15	MICROPHONE INSTALLATION .....	2-8
2.16.1	External Loudspeaker .....	2-8
2.16.2	Headset .....	2-8
2.17	OPERATIONAL CHECK .....	2-8
<b>SECTION 3 OPERATING INSTRUCTIONS</b>		
3.1	INTRODUCTION .....	3-1
3.2	OPERATOR'S SWITCHES, CONTROLS AND INDICATORS .....	3-1
3.3	PREPARATION FOR USE .....	3-4
3.4	OPERATION IN THE TRANSMIT MODE .....	3-4
3.5	OPERATION IN THE RECEIVE MODE .....	3-5
3.6	SWITCHING OFF .....	3-5
WARRANTY .....		
Appendix A..... TDP-90 Programming Software User's Guide (for USB ...)		A-1

**LIST OF FIGURES**

FIGURE	TITLE	PAGE
1.1	Transceiver - General View .....	1-3
1.2	Transceiver with Mounting Bracket - General View .....	1-4
1.3	Power Input Cable Assembly - General View .....	1-5
1.4	Microphone Assembly - General View .....	1-6
1.5	Antenna Assembly - General View.....	1-7
2.1	Frequency Set-Memory Module A5 - Component Layout .....	2-6
3.1	Transceiver Front Panel Layout .....	3-1

**LIST OF TABLES**

TABLE	TITLE	PAGE
1.1	Leading Particulars .....	1-8
2.1	Frequency Selection MHz .....	2-3
2.2	Frequency Selection KHz .....	2-4
3.1	Operator's Switches, Controls and Indicators .....	3-2



## SECTION 1 - GENERAL DESCRIPTION

### 1.1 INTRODUCTION

VHF/AM Mobile Transceiver System 860605 (TMS-100), manufactured by Technisonic Industries Limited, is a low power VHF/AM Transceiver, complete with Mounting Bracket, Power Input Cable, Microphone and Antenna.

#### 1.1.1 Purpose of the System

(1) **Intended Purpose and Use** - The system is intended for installation in airport service vehicles, such as cars, snowploughs, and grass cutters, to allow ground control over such vehicles while they are negotiating aircraft manoeuvring areas.

(2) **Brief Description of System Units** - VHF/AM Mobile Transceiver System 860605 (TMS-100) consists of the following items:

(a) Transceiver Model 90-6R, Part Number 861605-2, Series 1, is a low power VHF/AM transceiver which operates in simplex on six pre-programmable frequency synthesized channels, with 25 kHz channel spacing in the frequency range of 117.975 MHz to 138.000 MHz. The transceiver operates from a 12 volts dc nominal vehicle power supply (negative ground only). An optional extra cost dc to dc convertor P/N 863118-1 can be installed in the transceiver to allow operation from an input supply from 10.8 to 30.0 VDC. A general view of the transceiver is given in Figure 1.1. The transceiver is normally located under the dashboard of a vehicle using a mounting bracket and mounting hardware.

(b) Mounting Bracket, Part Number 913053-1, is a U-shaped aluminum alloy bracket which, together with items of hardware included in Mounting Hardware Kit P/N 869024-1, is used to mount the transceiver under the dashboard of a vehicle.

A view of the transceiver with mounting bracket is given in Figure 1.2.

(c) Power Input Cable Assembly, Part Number 863701, is a three-metre length of two-core cable terminated at one end by a two-pin, female contacts, connector, which mates with the two-pin, male contacts, connector located at the left-rear of the transceiver. The un-terminated end of the cable is connected to the 12Vdc vehicle power supply negative-ground during installation.

A view of the cable assembly is given in Figure 1.3.

(d) Microphone Assembly, Part Number 961070-1, consists of a Microphone and a mounting bracket, P/N RK6MB.

A general view of the microphone assembly is given in Figure 1.4.

The microphone is a rugged hand-held microphone housed in a high impact plastic case which includes a rear case hang-up button for storage on the mounting bracket. The dynamic microphone is a noise cancelling type with a pre-amplifier, press-to-talk switch, and a retractable three-cord cable terminated by a three-pin male contacts, connector which mates with the MIC/PTT connector located on the front panel of the transceiver.

The microphone dc supply for the microphone is supplied by the transceiver. The mounting bracket, provided with the microphone, should be mounted in a convenient location near the transceiver. A small screwdriver which can be used for releasing the modular plug located in the microphone head is supplied with the microphone.

A replacement plug-in microphone cord, P/N 963299-1 is available for this microphone. This cord is supplied with a modular microphone plug on one end and a three-pin DIN connector on the other to mate with the Model 90-6R Transceiver.

- (e) Antenna Assembly, Part Number 861910-1, is supplied complete as a kit which includes the following items: Antenna Base, which includes a mounting pad, together with a pad, braid nut, sleeve and clamp for termination of the antenna RF cable. The Antenna Rod is supplied with an Allen Wrench for adjustment of its set screws. The Antenna RF Cable is a ten-metre length RG58/U coaxial cable terminated at one end by an UHF, male contact, connector which mates with the UHF, female contact, antenna connector located at the right-rear of the transceiver. The antenna may be mounted on any flat surface, roof, cowl, fender or rear deck of a vehicle, however, rooftop mounting is recommended for best performance. A general view of the antenna assembly is given in Figure 1.5.

### 1.1.2 Modes of Operation

The transceiver may be operated in either of two modes; transmit or receive, as selected by the Press-to-Talk (PTT) switch on the microphone:

- (1) Transmit Mode - When the PTT switch on the microphone is depressed, the transceiver will operate in the transmit mode. The PTT signal line is grounded by the microphone switch via the microphone lead and the MIC/PTT connector to the transceiver. The Tx ON yellow LED will go ON, indicating that the transmitter is activated.

Transmission will occur on one of the six preset channel frequencies, determined by the setting of the CHANNEL SWITCH. The appropriate CHANNEL INDICATOR green LED 1, 2, 3, 4, 5 or 6, will be ON, indicating the channel selected.

- (2) Receive Mode - When the PTT switch on the microphone is released, the transceiver will operate in the receive mode. The Tx ON yellow LED will go OFF, indicating that the transmitter is de-activated. Reception on one of the six preset channel frequencies, as selected by the CHANNEL SWITCH will occur.

The appropriate CHANNEL INDICATOR green LED 1, 2, 3, 4, 5, or 6, will be ON, indicating the channel selected. The setting of the SQUELCH CONTROL determines the squelch threshold level. When the SQUELCH CONTROL is adjusted in the counter-clockwise direction, the SQUELCH INDICATOR green LED will go ON, indicating that the squelch circuit is connecting the demodulated audio to the VOLUME CONTROL. The setting of the VOLUME CONTROL determines the audio level produced from the internal loudspeaker. When the VOLUME CONTROL is adjusted in the clockwise direction, the audio level will increase.

**NOTE:**

**In certain installations, either an external loudspeaker or headphone may be fitted and connected to the SPEAKER/PHONE jack of the transceiver.**

When the connector of the external loudspeaker or headphone is connected to the transceiver SPEAKER/PHONE jack, the internal loudspeaker is disconnected and the VOLUME CONTROL will control the audio level applied to the external loudspeaker or headphone, as applicable.

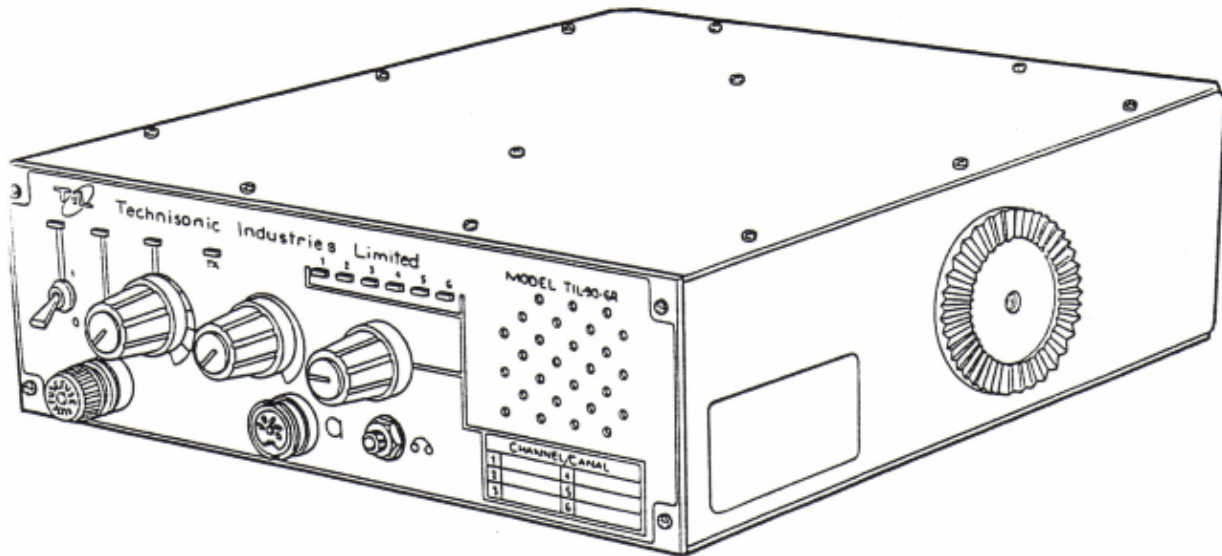
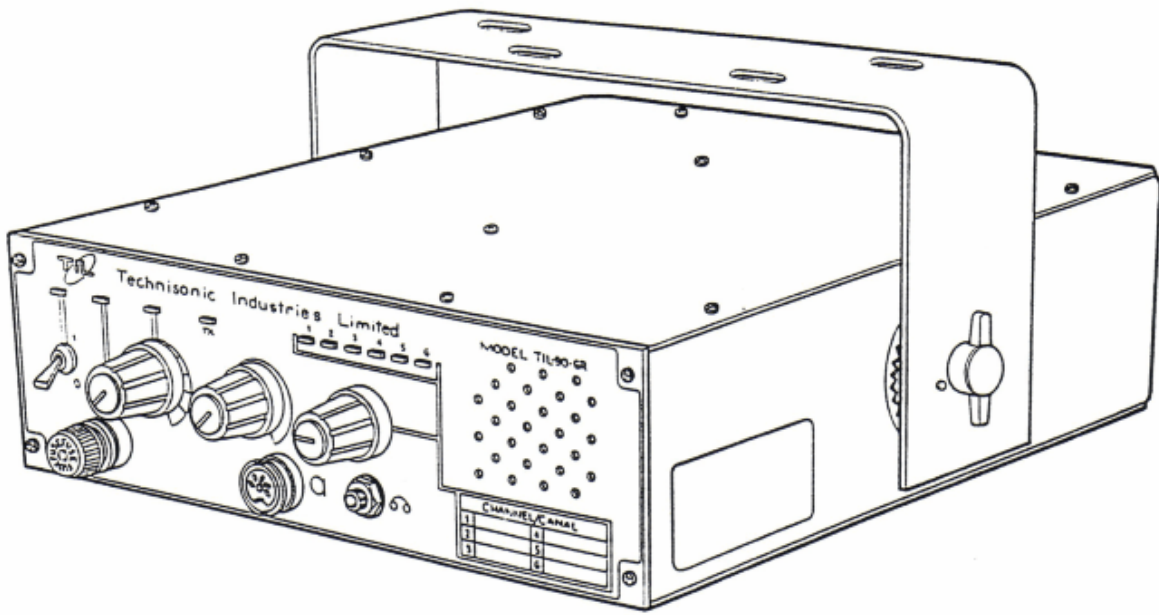

Figure 1.1 Transceiver - General View



**Figure 1.2** Transceiver with Mounting Bracket - General View

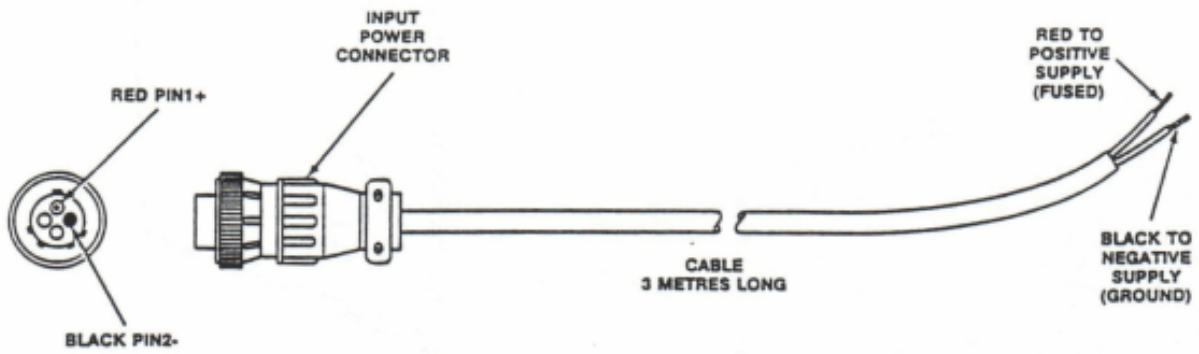

Figure 1.3 Power Input Cable Assembly - General View

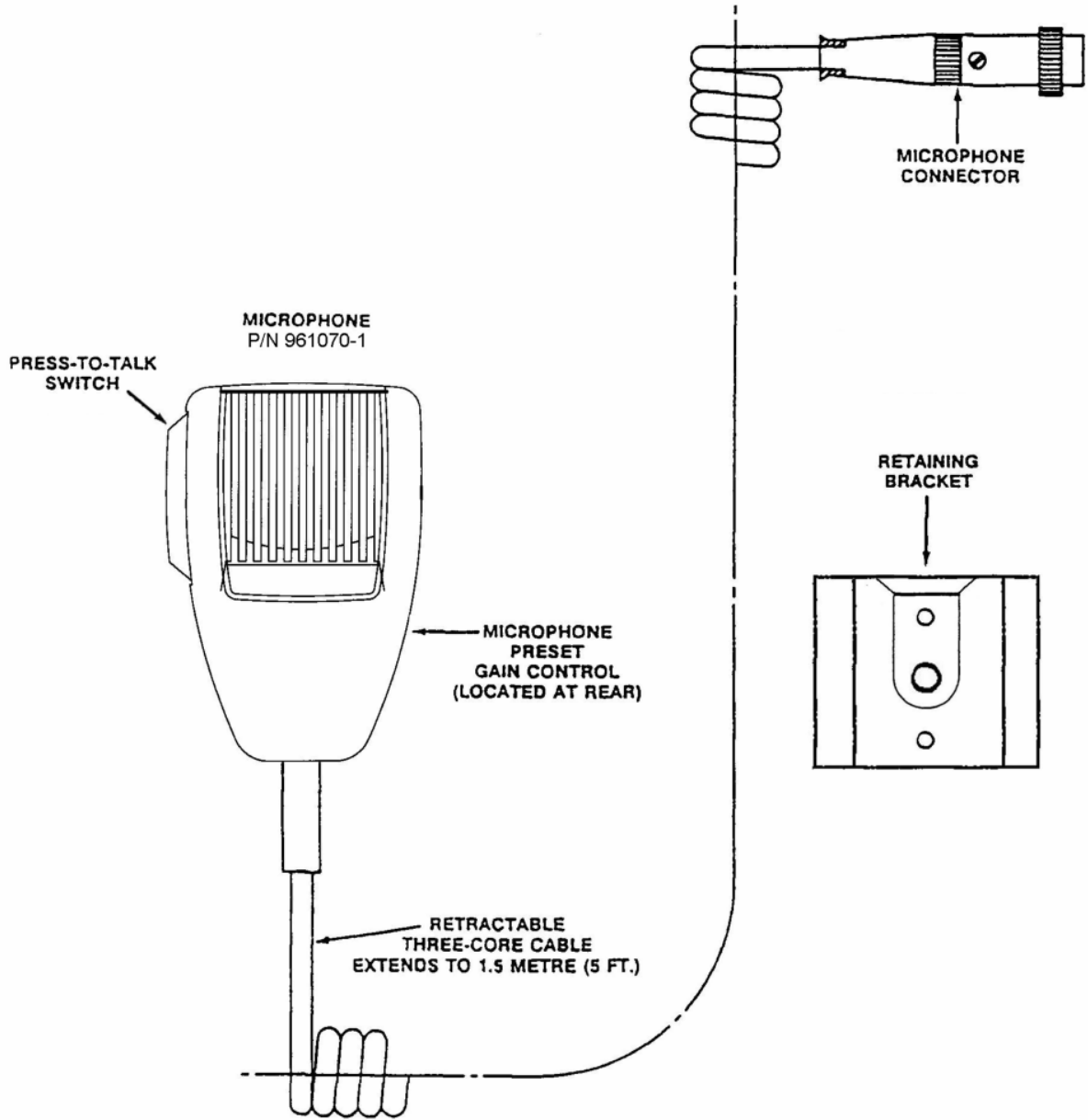
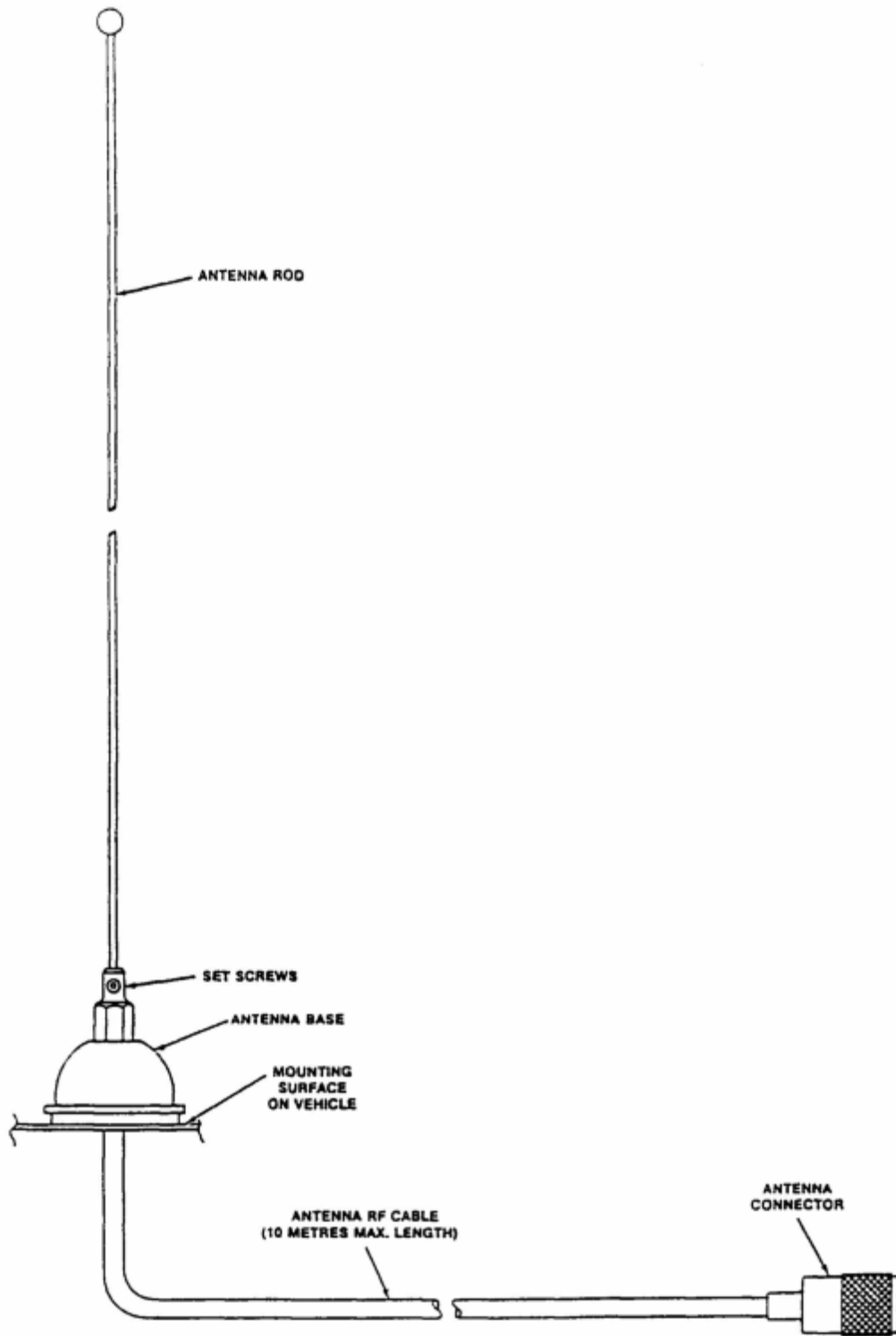

Figure 1.4 Microphone Assembly - General View



**Figure 1.5** Antenna Assembly - General View

**1.4 TECHNICAL SUMMARY**

A summary of the relevant electrical, operational, mechanical and physical characteristics of the transceiver are given in Table 1.1, Leading Particulars.

<b>TABLE 1.1 LEADING PARTICULARS</b>	
<b>TRANSCEIVER MODEL 90-6R:</b>	
Power Source Requirements:	
DC Voltage (Negative Ground) .....	13.75Vdc Nominal
Input Current::	
Transmit Mode .....	5.0A maximum
Receive Mode .....	1.5A maximum
Frequency Range .....	117.975MHz to 138.000MHz
Channel Spacing:	
Narrowband (Normal).....	25kHz
Frequency Selection.....	Six Preset Channels
Duty Cycle.....	One Minute Transmit/Four Minutes Receive
<b>TRANSMITTER CHARACTERISTICS:</b>	
Power Output (FCC) .....	10 Watts MAX
Power Output (ICAN) .....	8 Watts MAX
Output Power Stability After One Minute .....	±1 Watt
VSWR .....	4:1
Carrier Stability (-40°C to +55°C) .....	±1,000Hz maximum
Incidental FM and PM Due to Modulation .....	±100Hz max.
Rise Time to 90% of Rated Power .....	100milliseconds max.
Audio Input .....	50millivolts to 2Vrms
Speech Processor Dynamic Range .....	35dB minimum
Modulation Capability .....	Up to 95%
Audio Distortion (with 90% modulation) .....	10% maximum
Audio Frequency Response .....	300Hz to 2,500Hz, +1-3dB
Spurious Emissions .....	60dB below carrier
Hum and Noise Level .....	45dB below modulated carrier
<b>RECEIVER CHARACTERISTICS:</b>	
RF Input Circuit: .....	50-ohms unbalanced, VSWR 2:1 maximum
Sensitivity (12dB SINAD) 1kHz, 30% modulation .....	2 microvolts
Selectivity, 25kHz Channel Spacing:	
Bandwidth at 6dB Points .....	More than 15kHz
Bandwidth at 60dB Points .....	Less than 40kHz
Adjacent Channel Selectivity .....	At least 80dB
Pass Band Symmetry .....	15% maximum
IF Band Pass Ripple Between -6dB Points .....	2dB maximum
Spurious Response Attenuation .....	At least 90dB
Frequency Stability (-40°C to +55°C) .....	±1,000Hz max.
AGC Characteristics With RF Input Signal .....	5 microvolts to 1 volt
Audio Level:.....	±3dB



**TABLE 1.1 TRM-400 Series Transceivers - LEADING PARTICULARS (Continued)**

**RECEIVER CHARACTERISTICS (Continued)**

Intermodulation: Levels of Interference Signals

Are Shown To Produce Resulting SINAD of Not Less Than 6dB:

Ultimate Sensitivity (12dB) SINAD .....	67 dB
30microvolts, Input Signal .....	45 dB
300microvolts, Input Signal .....	30 dB
Unwanted Radiation.....	Less Than 80microvolts into 50-ohms

Hum and Noise With 1mV RF Signal, 30% modulation at 1kHz:

Ratio of Rx Audio Output to Residual Output with 0% modulation .....	At least 40dB
Interference Suppression .....	SINAD 6dB minimum

Audio Output Power and Distortion:

Loudspeaker Output .....	At least 3 Watts
Speaker Phone Output .....	100mW into 600-ohms
Distortion with RF Input, 1mV, 30% modulation .....	Less than 5%
Distortion with RF Input, 1mV, 90% modulation .....	Less than 10%
Audio Output Limiting .....	Less than 1dB, 30 to 100% modulation
Audio Frequency Response 300Hz to 2,500Hz .....	+1-3dB
Audio Acquisition Time .....	Within 100milliseconds

Audio Squelch Characteristic:

Squelch Type .....	Carrier Operated
Carrier Operated Squelch .....	Adjustable from 2 to 15microvolts

**ENVIRONMENTAL AND SERVICE CONDITIONS:**

Operating Temperature Range:

Full Performance .....	-40°C(-40°F) to +55°C(+131°F)
Slightly Degraded Performance .....	-41°C(-41.8°F) to -55°C(-67°F)
Storage Temperature Range .....	-55°C(-67°F) to +65°C(+149°F)
Ambient Relative Humidity .....	Up to 100%

This page left intentionally blank

---

## **SECTION 2 – CHANNEL FREQUENCY SELECTION AND INSTALLATION**

---

### **2.1 INTRODUCTION**

Transceiver Model 90-6R, Part Number 861605-2 as shipped from the plant, has Channel 1 operating frequency preprogrammed at 121.9000 MHz. Other channels are not preprogrammed. Before programming any other frequencies, perform an operational check, on Channel 1 at 121.9000 MHz, as outlined in paragraph 2.6. If there is any operational deficiency or equipment malfunction, the transceiver is to be returned to the manufacturer Technisonic Industries Limited, under warranty. Before installation in a vehicle, it is necessary to pre-program the operating frequency for each channel to be used at the particular airport.

**Early radios have their frequencies programmed by a diode matrix as described in Section 2.4. For radio units shipped after July 2012 and equipped with a USB port, please refer to Appendix A (TiL TDP-90 Programming Software User's Guide for USB Programmable AM Series Transceivers) - Document 11RE439.**

### **2.2 FREQUENCY RANGE**

The transceiver may be programmed for up to six frequencies over the frequency range 117.9750 MHz to 138.000 MHz with 25 kHz channel spacing.

### **2.3 PREPARATION**

Frequency Set-Memory Module A5 must be removed from the transceiver to allow frequency preprogramming as follows:

- (1) Place the transceiver on a bench with the top cover of the transceiver located on the bench and the bottom cover exposed.
- (2) Remove and retain twelve Philips Pan Hd Screws 4-40 X 1/4in. lg and No.4 Lockwashers securing the bottom cover to the main chassis of the transceiver.
- (3) Remove and retain the bottom cover.

**NOTE:**

**A folded ribbon cable is laid across the Frequency Set Memory Module A5. Carefully move this cable to one side while handling the Frequency Set-Memory Module A5.**

- (4) Remove and retain four Philips Pan Hd Screws 4-40 X 1/4in. lg and No.4 Lock washers securing the Frequency Set-Memory Module A5.
- (5) Gently pull, with a rocking action, the Frequency Set-Memory Module A5 in an upwards direction until its male pin connector A5J1 is disengaged from its mating connector A2J2 on Audio Synthesizer Module A2.

Remove Module A5 from the transceiver.

## 2.4 PREPROGRAMMING OF CHANNEL FREQUENCIES

Determine the number of channels to be used and the specific frequency of each channel for the particular transceiver being worked on. Prepare a list of channel number and frequencies to be preprogrammed, then proceed as follows:

### 2.4.1 Frequency Selection MHz

Having ascertained the desired operating frequency for a particular channel, refer to Table 2.1 Frequency Selection MHz.

Using the OPERATING FREQUENCY (MHz) column, find the desired frequency in MHz. Cross-refer to the DIODE LOCATION column, and record the locations in which diodes are to be installed, as indicated by a "1" entry.

### 2.4.2 Frequency Selection kHz

When the desired operating frequency includes kHz, refer to Table 2.2, Frequency Selection kHz.

Using the OPERATING FREQUENCY kHz column, find the portion of the desired frequency in kHz. Cross-refer to the DIODE LOCATION column, and record the locations in which diodes are to be installed, as indicated by a "1" entry.

#### NOTE:

**Channel 1 operating frequency is already preprogrammed for 121.9000 MHz. It will be necessary to remove existing diodes if changing Channel 1 from 121.9000 MHz.**

### 2.4.3 Installation of Diodes

Using the required number of diodes as determined during FREQUENCY SELECTION MHz and FREQUENCY SELECTION kHz, install each diode in its applicable location CR1 through CR72 for each channel to be used.

Ensure that each diode is installed using correct polarity, as shown in Figure 2-1, using Multicore Solder SN63, 1mm, or equivalent, and appropriate soldering iron. Trim leads on underside of printed wiring board and remove solder flux residue.

<b>TABLE 2.1 FREQUENCY SELECTION MHz</b>						
OPERATING FREQUENCY (MHz)	DIODE LOCATION					
	20 MHz	10 MHz	8 MHz	4 MHz	2 MHz	1 MHz
117	0	1	0	1	1	1
118	0	1	1	0	0	0
119	0	1	1	0	0	1
120	1	0	0	0	0	0
121	1	0	0	0	0	1
122	1	0	0	0	1	0
123	1	0	0	0	1	1
124	1	0	0	1	0	0
125	1	0	0	1	0	1
126	1	0	0	1	1	0
127	1	0	0	1	1	1
128	1	0	1	0	0	0
129	1	0	1	0	0	1
130	1	1	0	0	0	0
131	1	1	0	0	0	1
132	1	1	0	0	1	0
133	1	1	0	0	1	1
134	1	1	0	1	0	0
135	1	1	0	1	0	1
136	1	1	0	1	1	0
137	1	1	0	1	1	1
138	1	1	0	0	0	0

LEGEND: 0 = NO DIODE REQUIRED

1 = DIODE TO BE INSTALLED

**TECHNISONIC INDUSTRIES LIMITED**  
www.til.ca

<b>TABLE 2.2 FREQUENCY SELECTION kHz</b>						
OPERATING FREQUENCY (kHz)	DIODE LOCATION					
	800 kHz	400 kHz	200 kHz	100 kHz	50 kHz	25 kHz
000	0	0	0	0	0	0
025	0	0	0	0	0	1
050	0	0	0	0	1	0
075	0	0	0	0	1	1
100	0	0	0	1	0	0
125	0	0	0	1	0	1
150	0	0	0	1	1	0
175	0	0	0	1	1	1
200	0	0	1	0	0	0
225	0	0	1	0	0	1
250	0	0	1	0	1	0
275	0	0	1	0	1	1
300	0	0	1	1	0	0
325	0	0	1	1	0	1
350	0	0	1	1	1	0
375	0	0	1	1	1	1
400	0	1	0	0	0	0
425	0	1	0	0	0	1
450	0	1	0	0	1	0
475	0	1	0	0	1	1
500	0	1	0	1	0	0
525	0	1	0	1	0	1
550	0	1	0	1	1	0
575	0	1	0	1	1	1
600	0	1	1	0	0	0
625	0	1	1	0	0	1
650	0	1	1	0	1	0
675	0	1	1	0	1	1
700	0	1	1	1	0	0
725	0	1	1	1	0	1
750	0	1	1	1	1	0
775	0	1	1	1	1	1
800	1	0	0	0	0	0
825	1	0	0	0	0	1
850	1	0	0	0	1	0
875	1	0	0	0	1	1
900	1	0	0	1	0	0
925	1	0	0	1	0	1
950	1	0	0	1	1	0
975	1	0	0	1	1	1

LEGEND: 0 = NO DIODE REQUIRED

1 = DIODE TO BE INSTALLED

## 2.5 INSTALLATION OF MODULE A5

After frequency selection has been completed, Frequency Set-Memory Module A5 shall be installed in the transceiver as follows:

- (1) Locate Frequency Set-Memory Module A5 in position, engaging its male pin connector A5J1 into its mating connector A2J2 on Audio Synthesizer Module A2. Gently push Module A5 downwards until it is correctly located.
- (2) Secure Module A5 using four Screws and Lockwashers retained during disassembly. Tighten Screws. Reposition the folded ribbon cable across the module.
- (3) Install the bottom cover on the main chassis of the transceiver utilizing Screws and Lockwashers retained during disassembly. Tighten Screws.
- (4) On the front panel label of the transceiver, mark the channel designation label with the appropriate frequency against each channel preprogrammed.

## 2.6 OPERATIONAL CHECK

Connect the transceiver to a test bench, and perform an operational check of the transceiver in both transmit and receive modes of operation, checking each channel in use.

## 2.7 INSTALLATION - INTRODUCTION

This section gives the basic installation information for units of VHF/AM Mobile Transceiver System 860605 in a typical airport service vehicle. As there are many types of vehicles in use, some may require "tailor made" installation information.

## 2.8 TRANSCEIVER LOCATION

The first consideration when planning an installation in a vehicle is the location of the transceiver. The transceiver is normally located under the dashboard of a vehicle with the transceiver supported under the mounting bracket, as shown in Figure 1.2. Where space under the dashboard is limited, the transceiver could be supported above the mounting bracket, the reverse of Figure 1.2.

Consideration should also be given to allowing sufficient space behind the transceiver for the length of the antenna connector and the power supply connector when they are mated to the transceiver connectors.

## 2.9 VEHICLE POWER SUPPLY

Having determined the location of the transceiver, the point of connection to the vehicle power supply may be chosen. The transceiver will operate from a 12 or 24 volts dc nominal power supply with negative ground, which must be taken from a fused power source with a minimum of 5-ampere fuse in circuit. The transceiver will tolerate an input voltage over the range 11.0 to 15.0 Vdc.

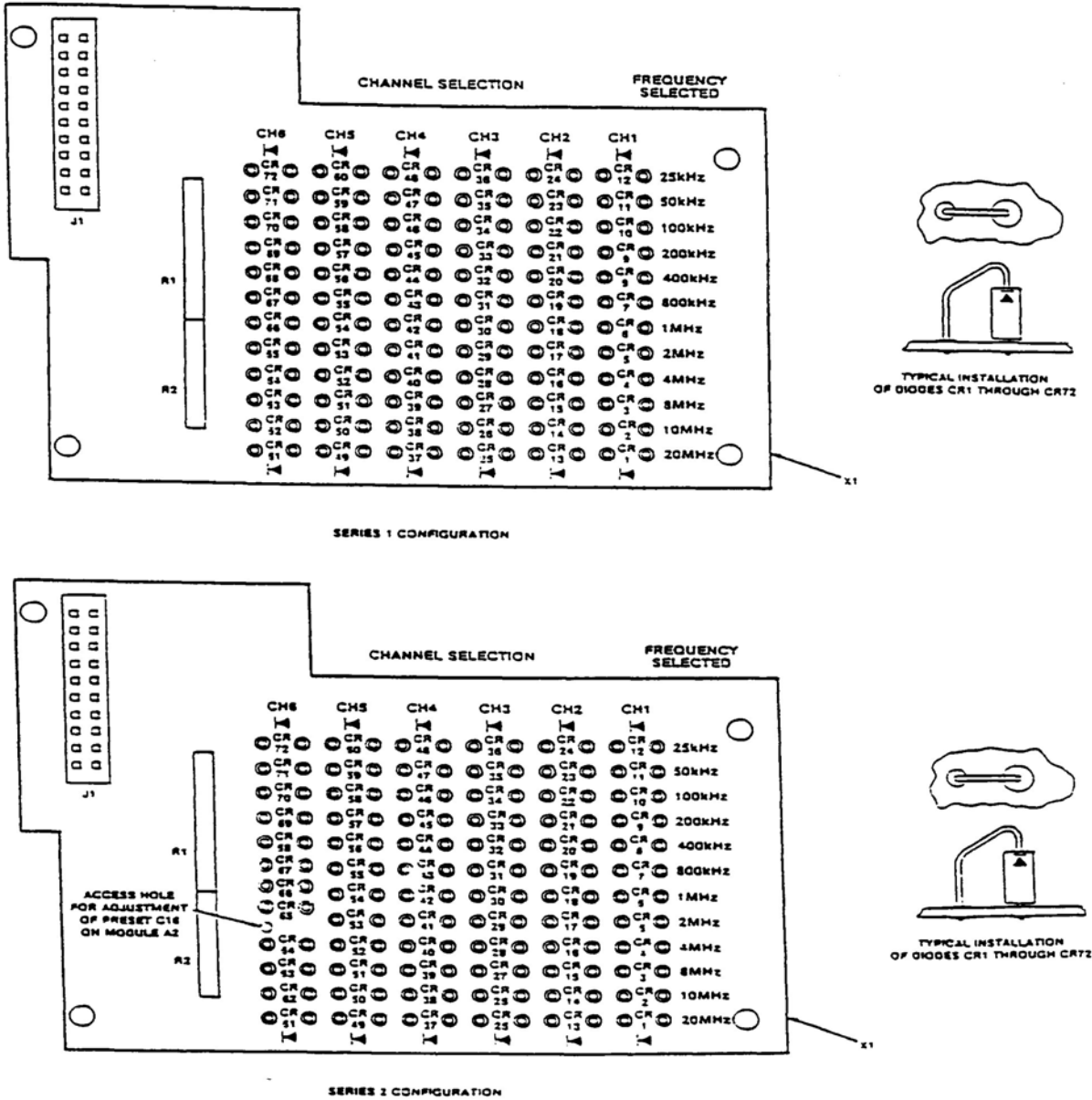

Figure 2.1 Frequency Set-Memory Module A5 - Component Layout



## 2.10 POWER INPUT CABLE ASSEMBLY

Using Power Input Cable Assembly, Part Number 863701, as shown in Figure 1.3, route the un-terminated end of the cable from the transceiver location to the point of connection to the fused vehicle power supply. The three-metre cable may be cut to length as required. Coiling of excess cable is NOT recommended. Strip the outer covering from the end of the cable, prepare the individual wire ends, and fit suitable terminals. Connect the red wire to the positive supply (fused), and connect the black wire to the negative supply ground.

## 2.11 ANTENNA ASSEMBLY

Antenna Assembly, Part Number 861910-1, is supplied as a kit which includes an installation leaflet. The antenna is shown assembled in Figure 1.5.

### 2.12.1 ANTENNA LOCATION

The antenna location is a very important factor in determining the performance of the system. The antenna may be mounted on any flat surface, roof, cowl, fender or rear deck of the vehicle, however, rooftop mounting is recommended for best performance.

### 2.12.2 ANTENNA INSTALLATION

Having determined the location of the antenna, route the un-terminated end of the antenna RF cable from the transceiver location. Using the antenna installation leaflet, follow the step-by-step instructions, and install the antenna. Any excess length of antenna RF cable should be cut-off before connection to the antenna.

## 2.13 MOUNTING BRACKET INSTALLATION

Mounting Bracket, Part Number 863801-1, should be installed in the transceiver location using Qty 4 Screws, Self-Tapping, Hex Hd with slot and shoulder No. 12 x 3/4 in. included in Mounting Hardware Kit, Part Number 869024-1. Refer to Figure 1.2 for a view of the transceiver with mounting bracket.

Using the mounting bracket as a template; on the mounting surface, mark the centre of each of the four slotted mounting holes, and drill a pilot hole using a No. 19 drill or equivalent (actual pilot hole size depends on the thickness of metal of mounting surface). Locate mounting bracket in position, and secure using the screws provided.

## 2.14 TRANSCEIVER INSTALLATION

Locate the transceiver in its approximate position, connect the antenna connector, and power cable connector to the appropriate connectors located at the rear of the transceiver.

Locate the transceiver into mounting bracket, and screw to bracket using two wing screws and nylon washers included in Mounting Hardware Kit, Part Number 869024-1. Adjust angle of transceiver as required, before tightening the two wing screws.

## 2.15 MICROPHONE INSTALLATION

Refer to Figure 1.4 for a general view of the microphone and retaining bracket. Determine a suitable and convenient location for Retaining Bracket and secure it using appropriate hardware (not provided). Connect the connector of Microphone, Part Number 961070-1 to the MIC/PTT connector located on the front panel of the transceiver.

## 2.16 OPTIONAL EXTERNAL LOUDSPEAKER OR HEADPHONE

Provision is made for connection of either an external loudspeaker or headphone to the SPEAKER/PHONE jack of the transceiver, as shown in Figure 4.1.

### 2.16.1 EXTERNAL LOUDSPEAKER

When an external loudspeaker is to be installed, an 8-ohm nominal impedance loudspeaker should be used. The loudspeaker cable should be terminated by a 1/4 in., 3-pole telephone plug (male), with the loudspeaker connected between tip and sleeve (ground). The External loudspeaker connector should be connected to the SPEAKER/PHONE jack located on the front panel of the transceiver. When the external loudspeaker connector is connected to the transceiver SPEAKER/PHONE jack, the internal loudspeaker is automatically disconnected.

### 2.16.2 HEADSET

When a headset is to be used, the headset impedance should be 150- to 600-ohms. The headset cable must be terminated by a 1/4in., 3-pole telephone plug (male), which mates with the SPEAKER/PHONE jack located on the front panel of the transceiver. When connected, the internal loudspeaker is automatically disconnected. The headset may be connected as detailed in (1) for receiver audio with no transmit sidetone audio, or (2) for receiver audio with transmit sidetone audio.

#### (1) HEADSET WITH NO TRANSMIT SIDETONE AUDIO

When receiver audio only with no transmit sidetone audio is required, the headset should be connected between the tip and sleeve (ground) of the telephone plug.

#### (2) HEADSET WITH SIDETONE AUDIO

When receiver audio with transmit sidetone is required, the headset should be connected between the tip and sleeve (ground) with a resistor (located inside the plug) connected between the tip and ring of the telephone plug. The function of the resistor is to reduce the transmit sidetone audio level to a suitable listening level. The value of the resistor is determined by the headset impedance and desired listening level. When a 600-ohm impedance headset is used, the value of the resistor should be approximately 10 kilohms. For headsets with lower impedance the resistor value may be different but must not be less than 240-ohms.

## 2.17 OPERATIONAL CHECK

Perform an operational check of the transceiver, checking each channel in use in both the transmit and receive modes of operation, using the Operating instructions given in Section 3 of this document and the appropriate specified operating procedures during transmission.

## SECTION 3 – OPERATING INSTRUCTIONS

### 3.1 INTRODUCTION

This section includes a functional description of each switch, control, indicator and connector located on the front panel of the transceiver, together with the PRESS-TO-TALK switch included on the microphone, together with operating instructions.

### 3.2 OPERATOR'S SWITCHES, CONTROLS AND INDICATORS

- (1) A view of the transceiver front panel is given in Figure 3.1. Front panel controls are identified by pictograms. Each pictogram shows the function performed by the control. These pictograms are translated into words by the annotations of the illustration.
- (2) A functional description of each of the operator's switches, controls and indicators, together with the microphone PRESS-TO-TALK switch, is given in Table 3.1, Operator's Switches, Controls and Indicators.

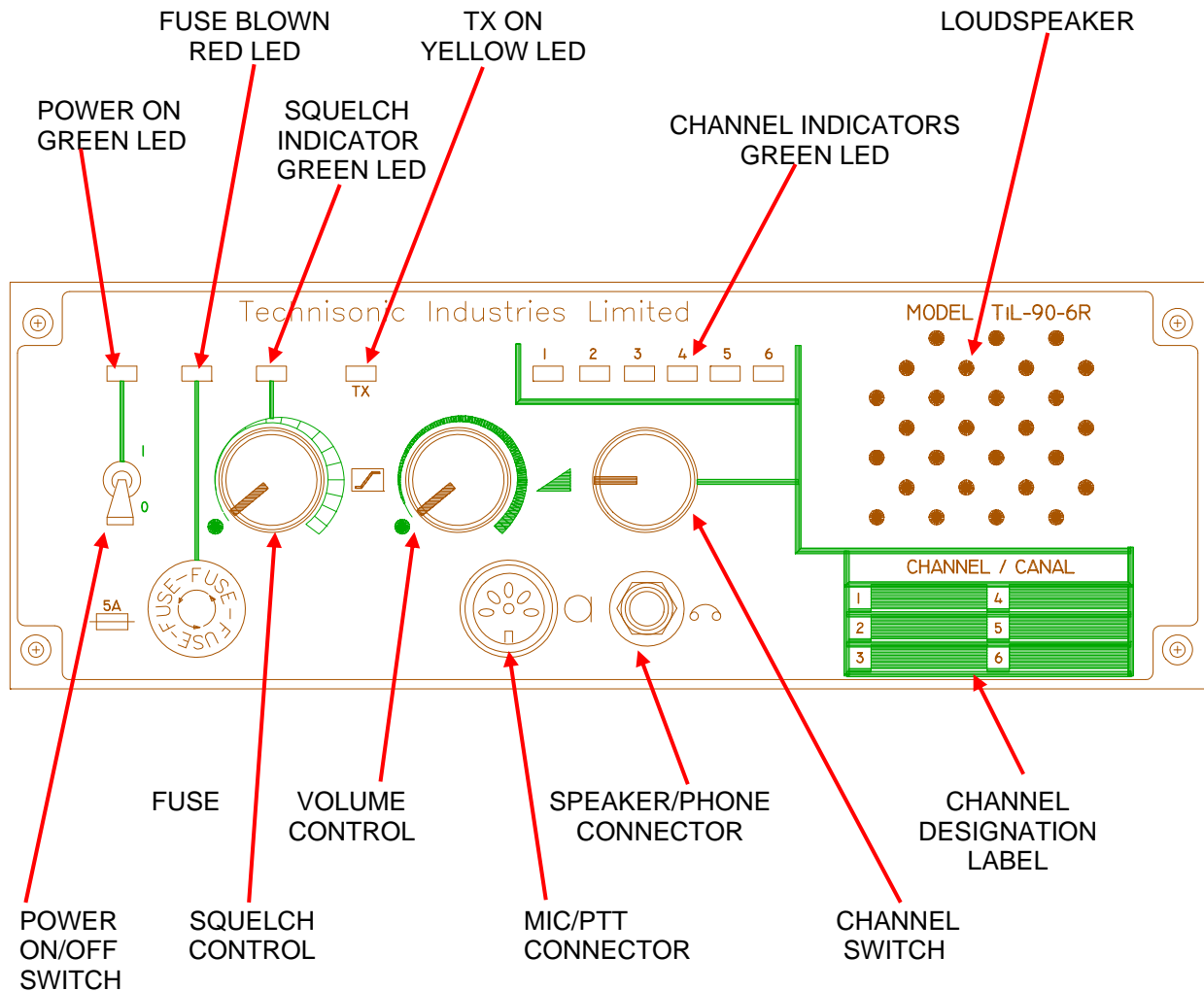

Figure 3.1 Transceiver Front Panel Layout

<b>TABLE 3.1 OPERATORS SWITCHES, CONTROLS AND INDICATORS</b>	
<b>SWITCHES CONTROLS &amp; INDICATORS</b>	<b>FUNCTIONAL DESCRIPTION</b>
POWER ON/OFF SWITCH	A two-position toggle switch which controls the application of the 12 volts nominal power supply to the transceiver.  Position 1, toggle UP, the transceiver is switched ON. Position 0, toggle DOWN, the transceiver is switched OFF.
POWER ON LED INDICATOR	A green LED which is ON when the POWER ON/OFF switch is set to Position 1, and the vehicle power supply is applied to the transceiver.
FUSE	A 5-ampere fuse which protects the 12/24 volts nominal power supply line. As part of reverse polarity protection, the fuse will "blow" when polarity of the vehicle supply line is reversed.
FUSE BLOWN RED LED INDICATOR	A red LED which is ON when the 5-ampere fuse is "blown", and the vehicle power supply is applied to the transceiver.
SQUELCH CONTROL	A linear potentiometer, which is operative when the transceiver is operated in the receive mode, determines the squelch threshold level. When the SQUELCH CONTROL is adjusted in the counter-clockwise direction, the SQUELCH green LED indicator will go ON, indicating that the squelch circuit is connecting the demodulated audio to the VOLUME control.
SQUELCH INDICATOR GREEN LED	A green LED which is ON when the squelch circuit is connecting the demodulated audio to the VOLUME control.
TX ON YELLOW LED INDICATOR	A yellow LED which is ON when the microphone PRESS-TO-TALK (PTT) switch is depressed, and the transceiver is operated in the transmit mode. When the microphone PTT switch is released, the Tx ON yellow LED goes OFF, and the transceiver is operated in the receive mode.
VOLUME CONTROL	A logarithmic potentiometer, which is operative when the transceiver is in the receive mode, determines the audio level applied to the internal loudspeaker.  When the SPEAKER/PHONE connector is in use the VOLUME CONTROL determines the audio level applied to the external loudspeaker or headphone, as appropriate, and the internal loudspeaker is disconnected.
MIC/PTT CONNECTOR	A 5-pin connector which performs two functions, one as the microphone/PTT connector, secondly as a test connector.  (1) It accepts the 3-pin connector of the microphone carrying the following: Pin 1 - PTT Signal Line Pin 2 - Microphone Signal Ground Pin 3 - Microphone Signal and Microphone DC Supply Line  (2) It accepts a 5-pin test connector, for use during bench testing. The additional pins provide the following test points: Pin 4 - AGC test voltage Pin 5 - Squelch test voltage

<b>TABLE 3.1 OPERATORS SWITCHES, CONTROLS AND INDICATORS</b> (Continued)	
<b>SWITCHES CONTROLS &amp; INDICATORS</b>	<b>FUNCTIONAL DESCRIPTION</b>
MICROPHONE PRESS-TO-TALK SWITCH	<p>When connected via the MIC/PTT CONNECTOR to the transceiver, the PRESS-TO-TALK (PTT) switch determines the operating mode of the transceiver.</p> <p>When the PTT switch is depressed, the transceiver will operate in the transmit mode.</p> <p>When the PTT switch is release, the transceiver will operate in the receive mode.</p>
CHANNEL SWITCH	A 6-position rotary switch which is used in both the transmit and receive modes to determine which one of the 6 pre-selected channels is in use.
CHANNEL INDICATORS GREEN LED	Six green LED's identified 1 through 6. The appropriate LED goes ON, indicating which channel has been selected by the CHANNEL SWITCH.
CHANNEL DESIGNATION LABEL	The CHANNEL DESIGNATION LABEL is used to record the operating frequency that was pre-selected for each channel during frequency selection, performed before installation of the transceiver.
LOUDSPEAKER	<p>An 8-ohm internal loudspeaker, which is operative in the receive mode, reproduces the audio line output. The audio line is disconnected from the internal loudspeaker when the transceiver is operated in the transmit mode.</p> <p>The audio line is also disconnected from the internal loudspeaker when the SPEAKER/PHONE connector is in use.</p>
SPEAKER/PHONE CONNECTOR	<p>A 3-pole connector which may be used in certain installations to provide interconnection to either an external loudspeaker or headphone.</p> <p>When used, the internal loudspeaker is disconnected, and the VOLUME control will control the audio level applied to the external loudspeaker or headphone, as applicable.</p>

### 3.3 PREPARATION FOR USE

To prepare the transceiver for use:

- (1) Remove the microphone from its mounting bracket, and ensure that the microphone connector is connected to the MIC/PTT connector of the transceiver.
- (2) Set the SQUELCH control in the fully counter-clockwise (CCW) position.
- (3) Set the VOLUME control in the 12 o'clock centre position.
- (4) Set the POWER ON/OFF switch to position 1, toggle-up "ON" position.
- (5) Verify that the FUSE BLOWN red LED is OFF.
- (6) Verify that the POWER ON green LED is ON.
- (7) Set the CHANNEL switch to the desired operating channel 1 through 6.
- (8) Verify that the appropriate CHANNEL INDICATOR green LED is ON.
- (9) Proceed to operation in the transmit mode, paragraph 3.4, or operation in the receive mode, paragraph 3.5, as appropriate.

### 3.4 OPERATION IN THE TRANSMIT MODE

To operate in the transceiver transmit mode, proceed as follows:

- (1) Hold the microphone in one hand, with the upper edge of the microphone as close as possible to the upper lip.  
  
This technique is necessary because the noise cancelling feature of the microphone favours sound close to the microphone and discriminates against sounds only 1/2 inch (12.7mm) or more away from the microphone.
- (2) Depress and hold the PRESS-TO-TALK switch of the microphone during transmission.
- (3) Ensure that the Tx ON yellow LED is ON.
- (4) Speak slowly and distinctly into the microphone using specified operating procedures during transmission.
- (5) When the message is ended, release the PRESS-TO-TALK switch of the microphone.
- (6) The transceiver is now operating in the receive mode.
- (7) Verify that the Tx ON yellow LED is OFF.

### 3.5 OPERATION IN THE RECEIVE MODE

To operate the transceiver in the receive mode, proceed as follows:

- (1) Ensure that the PRESS-TO-TALK switch on the microphone is NOT depressed, and verify that the Tx ON yellow LED is OFF.
- (2) Verify that the CHANNEL switch is set to the desired operating channel 1 through 6, and verify that the appropriate CHANNEL INDICATOR green LED is ON.
- (3) Adjust the SQUELCH control to suit location reception conditions. When the SQUELCH control is rotated in the clockwise direction, the SQUELCH indicator green LED will go ON, indicating that the squelch circuit is connecting the demodulated audio output to the VOLUME control.

Further adjustment of the SQUELCH control determines the squelch setting.

- (4) The VOLUME control can then be adjusted in a clockwise direction to increase the audio level, or in a counter-clockwise direction to decrease the audio level which can be heard on the internal loudspeaker.

#### NOTE:

**When an external loudspeaker or headset is connected to the SPEAKER/PHONE jack of the transceiver, the internal loudspeaker is automatically disconnected. The VOLUME control will now control the audio level applied to the external loudspeaker or headset as applicable.**

- (5) To change the operating channel, set the CHANNEL switch to the desired channel 1 through 6, and verify that the appropriate CHANNEL INDICATOR green LED is ON.

### 3.6 SWITCHING OFF

To switch off the transceiver:

- (1) Set the POWER ON/OFF switch to position 0, toggle down OFF position.
- (2) Verify that all indicator LED's on the front panel are OFF.

This page left intentionally blank



**Technisonic Industries Limited**  
240 Traders Blvd., Mississauga, ON Canada L4Z 1W7  
Tel: (905) 890-2113 Fax: (905) 890-5338

**IMPORTANT  
WARRANTY**

All communication equipment manufactured by Technisonic Industries Limited is warranted to be free of defects in Material or Workmanship under normal use for a period of one year from Date of Purchase by the end user.

Warranty will only apply to equipment installed by a factory approved and/or authorized facility in accordance with Technisonic published installation instructions. Equipment falling under the following is not covered by warranty:

- equipment that has been repaired or altered in any way as to affect performance,
- equipment that has been subject to improper installation,
- equipment that has been used for purposes other than intended,
- equipment that has been involved in any accident, fire, flood, immersion or subject to any other abuse.

Expressly excluded from this warranty are changes or charges relating to the removal and re-installation of equipment from the aircraft. Technisonic will repair or replace (at Technisonic's discretion) any defective transceiver (or part thereof) found to be faulty during the Warranty Period.

Faulty equipment must be returned to Technisonic (or its authorized Warranty Depot) with transportation charges prepaid. Repaired (or replacement) equipment will be returned to the customer with collect freight charges. If the failure of a transceiver occurs within the first 30 days of service, Technisonic will return the repaired or replacement equipment prepaid.

Technisonic reserves the right to make changes in design, or additions to, or improvements in its products without obligation to install such additions and improvements in equipment previously manufactured. This Warranty is in lieu of any and all other warranties express or implied, including any warranty of merchantability or fitness, and of all other obligations or liabilities on the part of Technisonic.

This Warranty shall not be transferable or assignable to any other persons, firms or corporations.

**For warranty registration please complete the on-line  
Warranty Registration Form found at [www.til.ca](http://www.til.ca).**



---

## APPENDIX A

---

*This document contains designs and other information which are the property of Technisonic Industries Ltd. Except for rights expressly granted by contract to the Canadian Government, or to the United States Government, this document may not in whole or in part, be duplicated or disclosed or used for manufacture of the part disclosed herein, without the prior permission of Technisonic Industries Ltd.*

# **TiL TDP-90 Programming Software User's Guide**

for USB Programmable  
AM Series Transceivers

DOCUMENT No.	11RE439
REVISION	A
DATE OF ISSUE	JULY 19, 2012



**Technisonic Industries Limited**

240 Traders Boulevard, Mississauga, Ontario L4Z 1W7

Tel: (905) 890-2113 Fax: (905) 890-5338

[www.til.ca](http://www.til.ca)

This page left intentionally blank.

## **INTRODUCTION**

This document contains instructions for proper installation and operation of the TDP 90 software for USB programmable Technisonic AM series transceivers and details the various elements of the Graphical User Interface (GUI).

**NOTE:** The images in this document are examples only and may not reflect your particular data settings, or current TDP software version.

The TDP-90 programming software can be found under the “Programming Software” link at <http://www.til.ca/>

## **SOFTWARE INSTALLATION**

**Note:** The USB driver must be installed before attempting to use the TDP-90 software.

### **USB Driver**

The USB hardware in your Technisonic AM transceiver is configured as a Virtual Com Port (“VCP”) which emulates a serial COM. This driver is available for free distribution from Future Technology Devices International (“FTDI”). Download and install the latest release of the VCP driver for Windows per the instructions on the web page located at this link:

<http://www.ftdichip.com/Drivers/VCP.htm>

### **TDP Software**

Download and install the latest release of the TDP-90 software for Windows from the web page located at this link:

<http://til.ca/content.php?page=programming-software-tdp90>

Once completed there will be a “TDP90” icon on your computer desktop.

## **TRANSCIVER TO COMPUTER CONNECTION**

Connect the transceiver to the computer USB port using a standard USB-A male to USB-B male cable. The USB port is located on the rear panel of mobile and base station transceivers and on the front panel of rack mount transceivers.

## **GETTING STARTED**

To start the TDP 90 program, double click the TDP90 icon on the desktop. The following Graphical User Interface will appear. The current version number is shown in square brackets on the title bar.

### **MAIN GRAPHICAL USER INTERFACE**

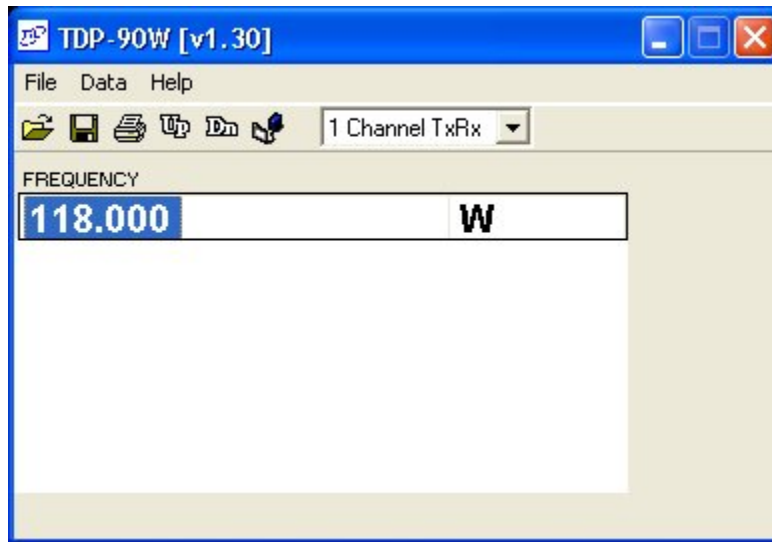

Figure 1

## ICONS AND PULL DOWN MENUS

The *icons and pull-down menus* provide the set-up and operating functions. The *Channels* pull-down tab provides selection for single or six channel transceivers (use the 6 channel window for 4 channel transceivers). The number of channels in the *Frequency editing window* changes accordingly. The frequency of each channel, as displayed in the *Frequency editing window*, can be changed by clicking on the desired channel window and entering the frequency..

### ICONS

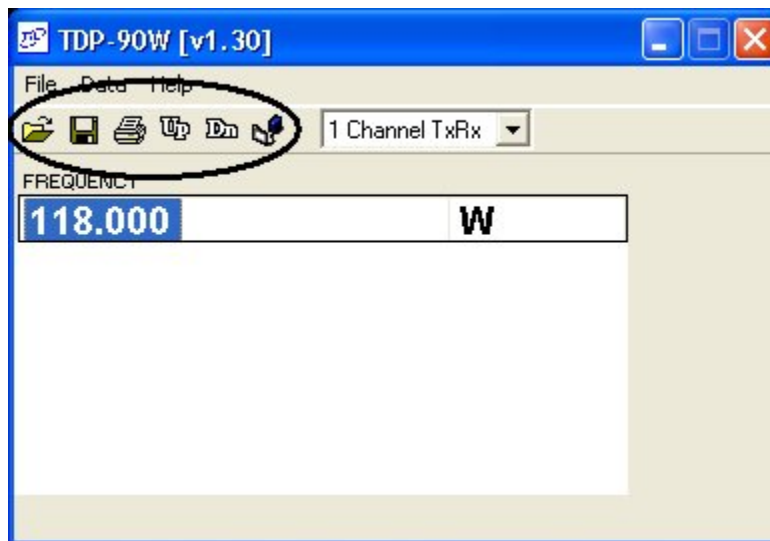

Figure 2

The icons provide single-click access to the features in the pull down menus. Details of these features are explained in the Pull Down Menu descriptions that follow.

**FILE MENU**

Figure 3

**Open** will allow you to select and load an existing file that was previously saved on disk. The yellow folder icon provides the same function in a single mouse click.

**Save** will allow you to save the current data into a file with a name of your choice. The filename may be any length up to 64 characters. The program will automatically append the .90 suffix to the filename. The diskette icon provides the same function in a single mouse click.

**Print** will create a text file of the channel list, as presented in the Frequency List window. Once the Print function is invoked, you will be prompted to enter the serial number of the currently connected transceiver. The printout will append a header to the top of the page that includes the serial number of the transceiver as well as the time and date. The printout can be filed as a record of the frequencies that are programmed into that particular transceiver. The printer icon provides the same function in a single mouse click.

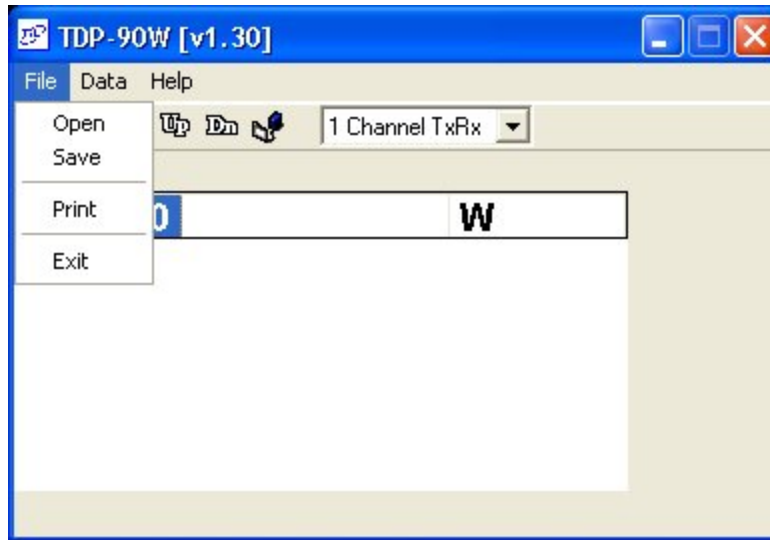
**Exit** will quit the TDP-90 program. If you have not saved your data, or if any changes were made to your data set since your last save, the TDP will warn you of this, and allow you to do so before quitting.



## DATA MENU

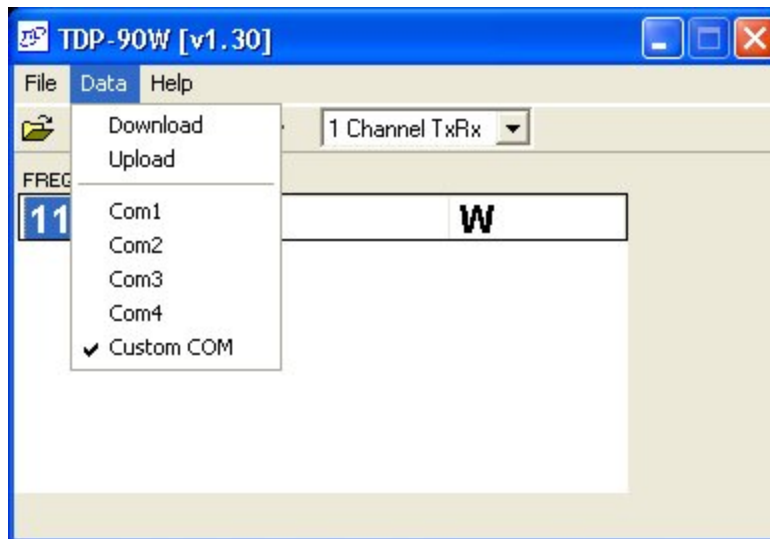
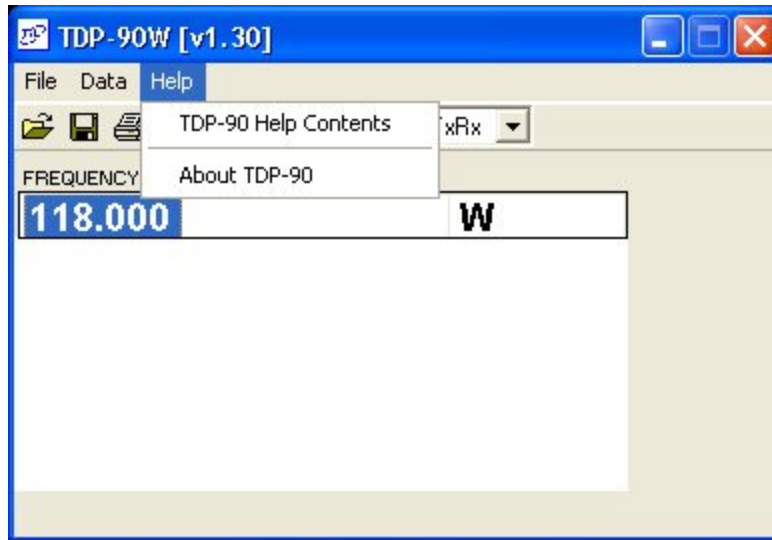

Figure 4

**Download (to Radio)** instructs the TDP 90 software to transfer the frequency data in the list to the memory channels in the connected AM transceiver. The Dn icon provides the same function in a single mouse click.

**Upload (from Radio)** instructs the TDP 90 program to wait for and read the channel data from the memory channels in the connected AM transceiver. The Up icon provides the same function in a single mouse click.

**Com1 (2,3,4, Custom COM)** allows you to select the COM port on your computer to which the transceiver is connected. The computer may assign a random unused COM port number to the Virtual Com Port (VCP) when the USB driver is installed so “Custom COM” can be selected when it is beyond the normal range of COM1-4. The assigned VCP can be determined by accessing the Device Manager (access in WinXP by right-clicking on “My Computer – Properties – Hardware – Device Manager – Port (COM & LPT) ). Note the COM number that was assigned to USB Serial Port. The Port (5th) icon provides the same function in a single mouse click.

**HELP MENU****Figure 5**

**TDP-90 Help Contents** opens the Windows Help dialog for the TDP-90 software. Here, you will find hardware connection and operating information as well as troubleshooting tips and answers to some Frequently Asked Questions.

**About** selection displays Technisonic company and contact information as well as the revision number of the TDP software in the “Terminal window” screen.

**CHANNEL SELECTION PULLDOWN**

**1 CHANNEL TRANSCEIVER**

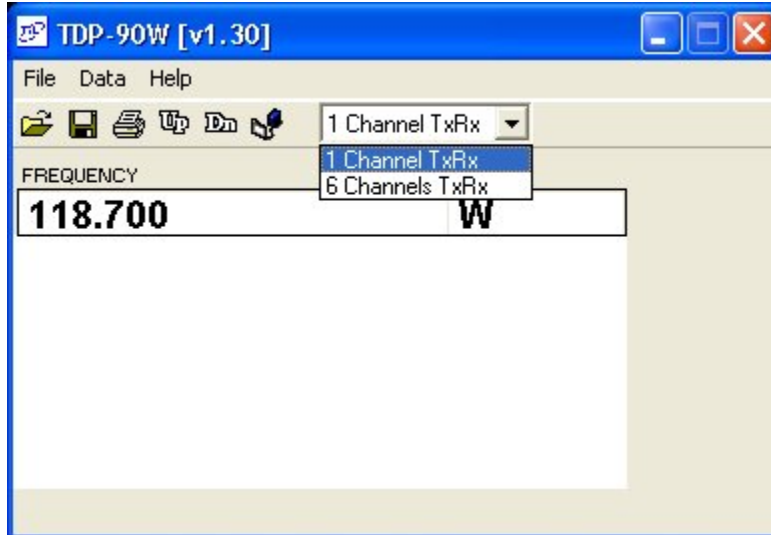

**Figure 6**

**6 CHANNEL TRANSCEIVER**

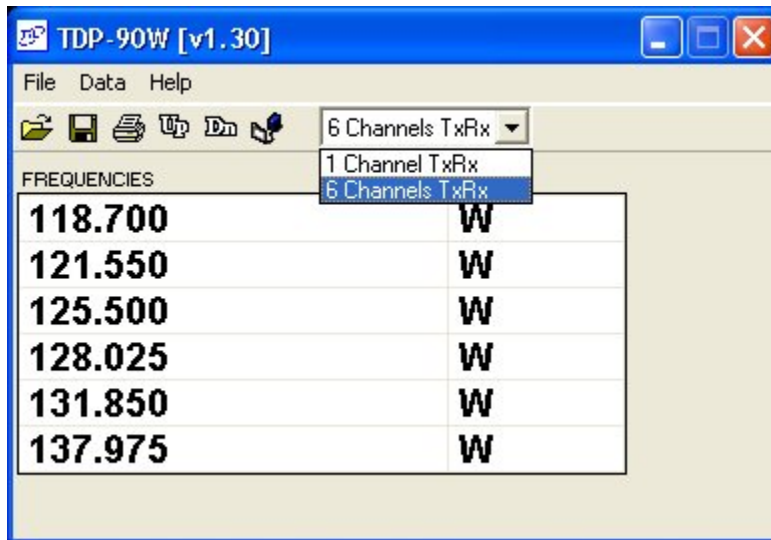

**Figure 7**

The **x Channel(s)** pull-down tab allows you to select for single or six channel AM transceiver use. The frequency editing window changes accordingly. The “W” indicates that the channels are 25kHz (**Wide**) channel spacing and as such, only channels in 25kHz increments are accepted. Be sure to set the channel pulldown appropriately for your transceiver otherwise frequency programming may be unpredictable. For 4 channel transceivers use the first 4 entries in the 6 channel window.

**SAMPLE UPLOAD AND DOWNLOAD**

- (1) Connect the transceiver to the computer USB port using a standard USB-A male to USB-B male cable. The USB port is located on the rear panel of mobile and base station transceivers and on the front panel of rack mount transceivers. Turn on the power to the transceiver.
- (2) Assuming that the USB driver is already installed, determine which Virtual Com Port has been assigned by accessing the Device Manager (accessed in WinXP by right-clicking on "My Computer – Properties – Hardware – Device Manager – Ports (COM & LPT) ). Note the COM number that was assigned to USB Serial Port.
- (3) Run the TDP-90 program on the computer.
- (4) Click on the **Data** pull-down list and select the serial port to which the transceiver is connected. Select Custom COM and enter the assigned port number if it is outside the normal range of Com1-4.
- (5) Set the program for 1 or 6 channels as applicable using the channel pulldown list.
- (6) Click on the **Up** icon to retrieve the frequencies from the radio. "UPLOADING" will appear at the bottom of the window as data is being transferred.
- (7) Edit the frequencies as desired. (The program only accepts 25 kHz spaced frequencies.)
- (8) Click on the **Dn** icon to copy the frequencies to the transceiver. "DOWNLOADING" will appear at the bottom of the window as data is being transferred.
- (9) Click on the **diskette** icon to save the file. Hint: Use the transceiver serial number or some other unique filename to identify the specific transceiver. The program will automatically append the .90 suffix to the filename.
- (10) Click on the **printer** icon to print a hard-copy of the frequencies.