

SAFE 128
Avionics Cooling Fan
With Fault Detection

INSTALLATION INSTRUCTIONS



1.1 INTRODUCTION

This sheet describes the installation of the SAFE 128 avionics cooling fan with fault detection output. It is intended for use by FAA certified repair stations to install the SAFE 128 and includes both mechanical and electrical installation information. The installer should insure that the SAFE 128 is operating according to its intended function.

1.1 PRODUCT DESCRIPTION

The SAFE 128 is an avionics cooling fan that provides an operating indication. When the fan is normally operating, this output is at low impedance. The output goes to high impedance whenever the RPM of the motor drops below a preset threshold, signaling the connected avionics of the reduction in cooling from the SAFE 128.

1.2 TECHNICAL CHARACTERISTICS

1.2.1 PHYSICAL CHARACTERISTICS

Width	2.36"	Height	2.87"
Depth	1.44" (inc. pins)	Weight	0.25 lb

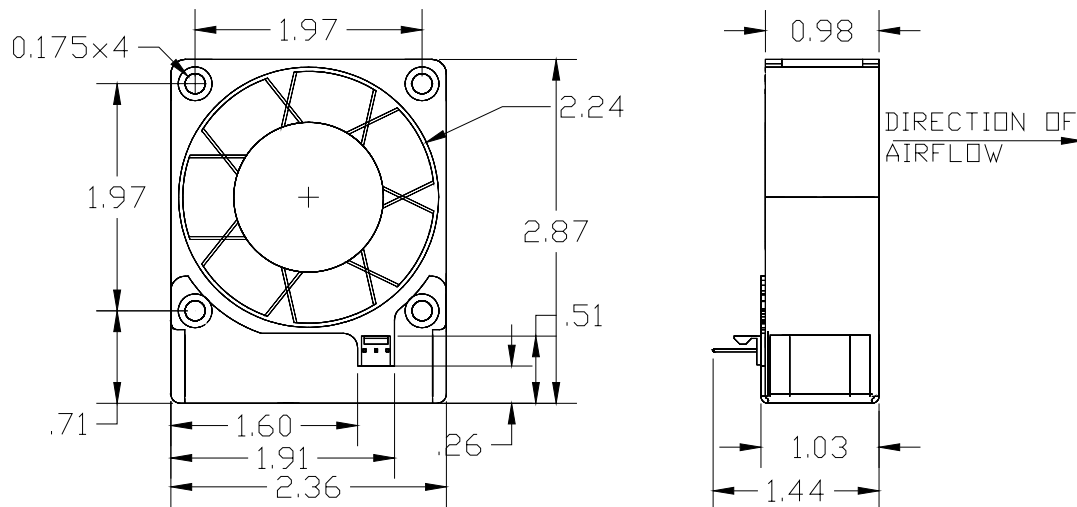

1.2.2 OPERATIONAL CHARACTERISTICS

Operating Voltage	22-31Vdc
Current	Operating .100 Amps Nominal Start-up <.250 Amps
Air Flow (No Load)	20 CFM (10CFM @ .08" H ₂ O)
Operating Temp	-20 to +55 °C
Max Operating Altitude	55,000 Feet

1.2.3 CERTIFICATION

FAA-PMA	PQ0894SW Diamond DA40
DO 160D	[F1]BAA[S2R2(B2,M)]XXXXXXXXZBAZA[XX]M[XXXX][XX]XX

2.0 INSTALLATION PROCEDURES

2.1 GENERAL

The SAFE 128 is supplied with a mounting connector and four contacts. Only three contacts are required and the spare one is provided in case one is destroyed during installation. The SAFE 128 is also shipped with a mating connector attached to the unit itself. This is to protect the pins during transit. This connector can be discarded once the unit is received or may be retained to cover the pin in case return shipment to the factory is necessary. The SAFE 128 is mounted with four (4) number 6 or 8 screws.

2.2 EQUIPMENT REQUIRED

2.2.1 Supplied

SAFE 128 System

Includes:	SAFE 128 Fan	305468-00
	Installation Kit	305477-00
	Mating Connector	305479-03
	Mating Pins	305478

2.2.1 REQUIRED BUT NOT SUPPLIED

Four (4) Number 6-32, 8-32 or equivalent mounting screws

2.3 MOUNTING

The SAFE 128 mounts with four number (4) 6-32 or 8-32 or equivalent machine screws. Be sure to observe the direction of airflow.

2.4 ELECTRICAL

The SAFE 128 operates on 28Vdc. It will provide a low on Fan Fail (center pin) of the connector when operating normally. When airflow drops to 60% of nominal, as determined by fan RPM, Fan Fail will output a high. An external pull-up is required. Power to the SAFE 128 can be supplied from the aircraft buss or from the unit to be cooled if an output is available. If connected to the aircraft buss, the SAFE 128 should be protected by a .5 amp fuse or breaker.

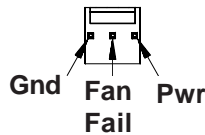

Description	Manufacturer	Series Number	Manf. Part Number	Sandia Part Number
Connector Housing	Molex	2695	22-1-3037	305479-03
Crimp Contact	Molex	2759	08-50-0114	305478
Hand Crimper Tool	Molex	NA	*11-01-0185 or CR2262C	NA
Extraction Tool	Molex	NA	*11-03-0022	NA
Insertion Tool	Molex	NA	*63812-0000	NA

*or equivalent

Mating Connector and Contact Information

2.5 CALIBRATION

No calibration of the SAFE 128 is required. The unit can be tested by slowing the fan manually and observing a high present on the Fan Fail pin. Allow the fan to return to normal speed and observe a low on the Fan Fail pin.

2.6 CONTINUED AIRWORTHINESS

Maintenance of the SAFE 128 is on condition only. No scheduled maintenance is required.

Avionics Cooling Solutions

Increase Your Avionics Reliability

It is well known that reducing the temperature at which electronics components operate increases their life expectancy. The avionics you depend on for critical navigation and communication functions endure one of the harshest environments of any electronics...the avionics stack! Today's avionics are housed in smaller and smaller packages that retain heat. They are also subjected to chimney effect, where the heat from the bottom radios rise throughout the entire radio stack, increasing overall operating temperatures. Today's engineers are making greater use of surface mounted devices to reduce size and weight. And although these devices use less power, they can be more sensitive to heat. Fortunately, removing heat from your avionics is easy and inexpensive, making a cooling fan one of the best investments you can make when installing your new avionics. A cooling fan from SANDIA aerospace will give you the peace of mind knowing your avionics will continue to operate at peak performance.

The Choice Is Up To You

SANDIA aerospace offers a variety of cooling solutions to choose from. For most avionics stacks, a three port fan will provide all the cooling you need, two navigation units and a transponder. For more complex panel, try the five port fan. Used ports can be capped and reserved for use on later system upgrades

Know When You Lose Your Cool

For critical applications, SANDIA offers three cooling solutions that have a fault detection output that will notify you whenever the cooling unit drops below a preset level. This will allow you to obtain service on the unit as soon as practical, reducing any failure possibilities to your avionics.

Technical Specifications

Model	Operating Voltage	Current Draw	Size	Weight	Fault Detection	Certification
ACF 314	14 Vdc	960 mA nominal (1.7A startup)	5.18" x 5.18" x 2.1"	1.18 lb	No	FAA-PMA
ACF 328	28 Vdc	480 MA Nominal (.85A startup)	5.18" x 5.18" x 2.1"	1.18 lb	No	FAA-PMA
ACF 528	28 Vdc	480 mA nominal (.85A startup)	5.13" x 6.77" x 2.1"	1.18 lb	No	FAA-PMA
SAFE 328	22-31 Vdc	400 mA nominal (550 mA startup)	5.58" x 4.75" x 1.25"	.70 lb	Yes	FAA-PMA
SAFE 528	22-31 Vdc	400 mA nominal (550 mA startup)	5.13" x 6.77" x 2.1"	1.23 lb	Yes	FAA-PMA Pending
SAFE 128	22-31 Vdc	100 mA nominal (.250 mA startup)	2.36" x 2.87" x 1.44"	.25 lb	Yes	FAA-PMA



3700 Osuna Rd NE

Suite 711

Albuquerque, NM 87109

www.sandia.aero

CF1012-1000