



SANDIA aerospace

Installation Manual

AIS 240-35

AIS 240A-35



This document and the information contained herein is the proprietary data of SANDIA aerospace. No part of this document may be transmitted, reproduced, or copied in any form or by any means without the prior written Consent of SANDIA aerospace. Due to SANDIA aerospace's continued product and quality improvement programs, information contained in this document is subject to change without prior notice. Copyright 2013 SANDIA aerospace. All rights reserved. Printed in USA.

Record of Revisions

Revision	Date	Description	Approval
A	9/6/13	DRN439	Leah Harrison

Table of Contents

Record of Revisions.....	i
Table of Contents	ii
List of Illustrations.....	ii
Section 1 General Description.....	1
1.1 Introduction.....	1
1.2 Product Description	1
1.2.1 Product Variations	1
1.3 Technical Characteristics	1
1.3.1 Physical Characteristics	1
1.3.2 Electrical Characteristics	1
1.4 Certification	1
Section 2 Installation Considerations	2
2.1 Introduction.....	2
2.2 Mounting.....	2
2.3 Cooling	2
2.4 Electrical	2
Section 3 Installation Procedures.....	3
3.1 General.....	3
3.2 Equipment Required	3
3.2.1 Supplied	3
3.2.2 Required But Not Supplied	3
3.3 Mounting.....	3
3.4 Electrical	4
3.5 Operating Instructions and Limitations	4
3.6 Calibration	4
3.7 Continued Airworthiness.....	4

List of Illustrations

Figure 3-1	Mounting Dimensions.....	3
Figure 3-2	AIS 240A-35 Schematic and Pin Out	4
Figure 3-3	AIS 240-35 Schematic and Pin Out	5

SECTION 2

INSTALLATION CONSIDERATIONS

1.1 Introduction

This Manual describes the installation of the AIS 240-35 and AIS 240A-35 Switching Modules. It is intended for use by FAA certified repair stations and original equipment manufacturers (OEM's) to install the units and includes both mechanical and electrical installation information. The installer should insure that the Switching Modules are operating according to their intended function.

1.2 Product Description

The AIS 240-35 and AIS 240A are 24 pole signal level switching units. The contact switching rating is limited by the circuit board track current capacity to 1.0 Amps.

1.2.1 Product Variations

The Model **AIS 240-35**, Sandia Part Number AIS 240-35 is the original variation and uses 6 relays of four poles each to provide the 24 poles of switching.

The Model **AIS 240A-35**, Sandia Part Number 306120-00 is a direct replacement for the AIS 240-35. It uses 12 relays in a series/parallel arrangement to provide the same 24 poles of switching. The AIS 240A addresses the obsolescence of the AIS 240-35 relays. While the mechanical package and installation of the AIS 240A is identical to the AIS 240-35, there is a slight weight variation. See the physical Characteristics for the weight of each unit.

1.3 Technical Characteristics

1.3.1 Physical Characteristics

	AIS 240-35	AIS 240A-35
Length	5.13"	5.13"
Width	3.46"	3.46"
Height	1.20"	1.20"
Weight	0.45 lb.	.50 lb.

1.3.2 Electrical Characteristics

	AIS 240-35	AIS 240A-35
Operating Voltage	28 Vdc	28 Vdc
Current	120 mA (All Relays Engaged)	160mA (All Relays Engaged)
Max Operating Temp.	-20°C to +55°C	-20°C to +55°C
Max Operating Altitude	50,000 ft.	50,000 ft.
Contact Rating	1.0 A @30 Vdc	1.0 A @30 Vdc

1.4 Certification

AIS 240-35 FAA-PMA

DO-160C Env. Cat. [A1D1]-CA(MN)XXXXXXXXZBABATZXXX

AIS 240A-35 FAA-PMA Pending

SECTION 2

INSTALLATION CONSIDERATIONS

2.1 Introduction

The AIS 240-35 and AIS 240A-35 have been designed to provide 24 poles of signal level switching.

2.2 Mounting

The AIS 240-35 and AIS 240A-35 can be mounted in any axis either inside or outside the pressure vessel. The units are mounted with 4 each number six or eight mounting screws (not provided).

2.3 Cooling

The AIS 240-35 and AIS 240A-35 do not require external cooling.

2.4 Electrical

The AIS 240-35 and AIS 240A-35 will operate on 18 to 32.0 Vdc. The AIS 240-35 and AIS 240A-35 units are supplied with a 78 pin Sub-D connector, Sandia Part Number 204508-1 and 80 crimp contacts, Sandia Part Number 305070. Extra pins can be discarded upon completion of the installation. Power and ground wires should be #22 AWG or larger.

SECTION 3

INSTALLATION PROCEDURES

3.1 General

The AIS 240-35 and AIS 240A-35 are supplied with a 78 pin Sub D mounting connector and 80 crimp style contacts. The AIS 240-35 and AIS 240A-35 are hard mounted in any axis using four (4) number 6 or 8 screws.

3.2 Equipment Required

3.2.1 Supplied

Model AIS 240-35, Sandia Part Number AIS 240-35 or Model AIS 240A-35, Sandia Part Number 306120-00.

Electrical Installation Kit Sandia Part Number 305552-00. The installer may also use the manufacturer's part in lieu of the Sandia Part. The Manufacturer and their part number(s) are listed below along with the Sandia Part Numbers.

1 each	204508-1 Connector Housing (AMP/TYCO P/N 204508-1)
1 each	305055 Connector Clamp (AMP/TYCO 1-5207908-3)
80 each	305070 Crimp Contacts (AMP/TYCO P/N 204351-1)

3.2.2 Required But Not Supplied

Four (4) Number 6 or Number 8 or equivalent mounting screws.

3.3 Mounting

The AIS 240-35 and AIS 240A-35 mount with four (4) Number 6, 8 or equivalent machine screws in the four holes in the units mounting flanges.

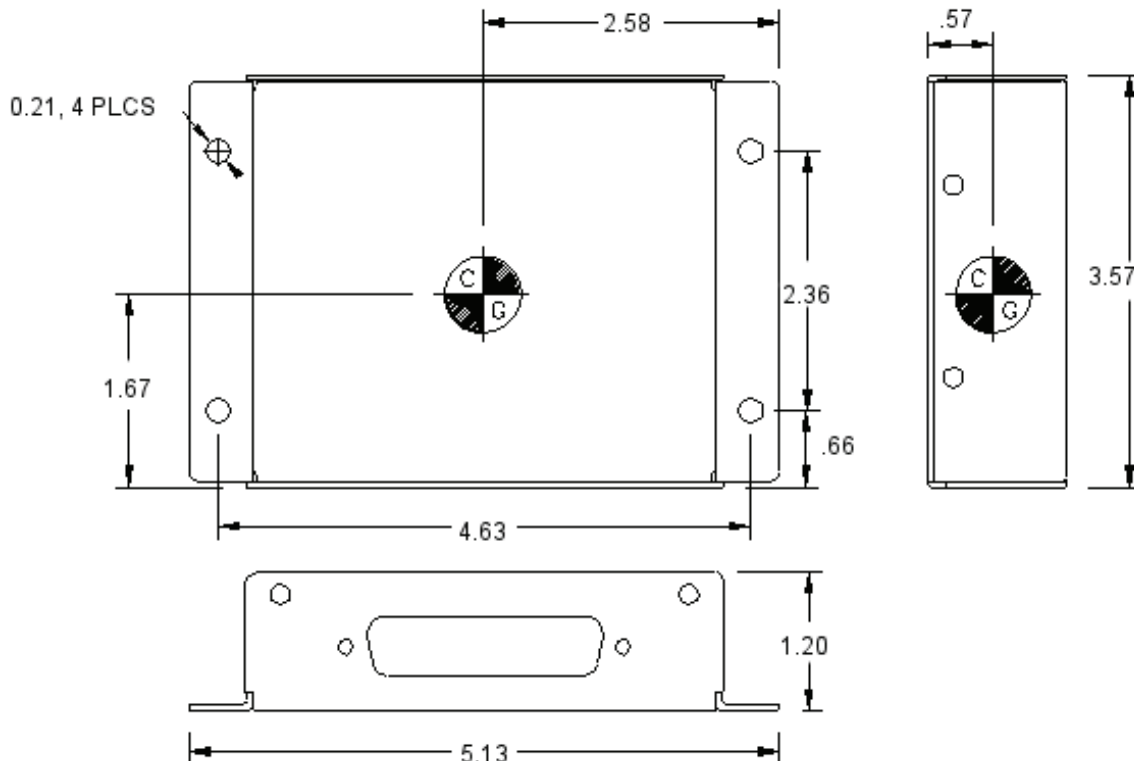

Figure 3-1
Mounting Dimensions

3.4 Electrical

The AIS 240-35 and AIS 240A-35 use 28 Vdc relays for the control HI input and a Control low for activation of the relays. There is no difference in the interconnect wiring between the AIS 240-35 and AIS 240A-35.

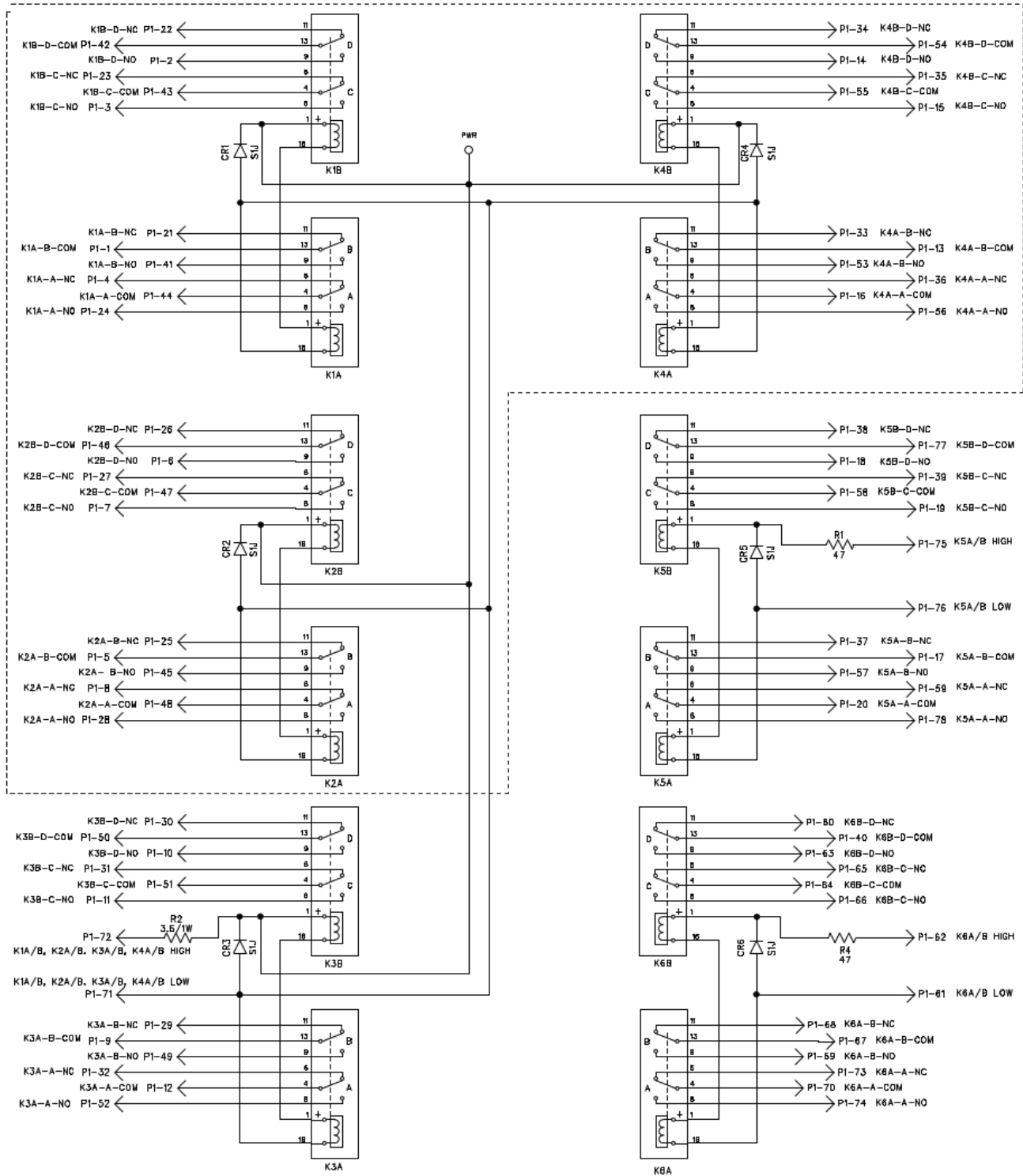

Figure 3-2
AIS 240A-35 Schematic and Pin Out

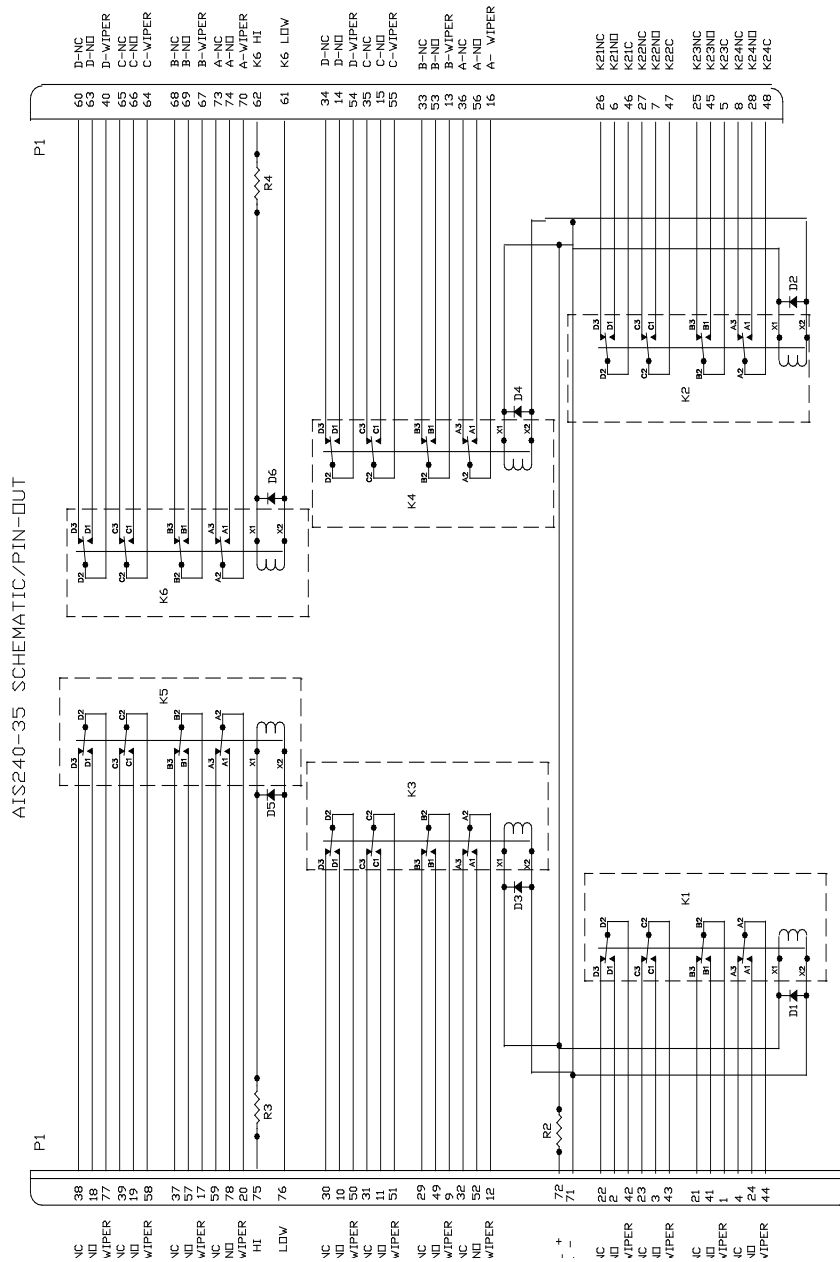

Figure 3-3
AIS 240-35 Schematic and Pin Out

3.5 Operating Instructions and Limitations

Refer to the equipment being switched for operation and Limitations.

3.6 Calibration

No calibration is required

3.7 Continued Airworthiness

Maintenance of the AIS 240-35 and the AIS 240A-35 is on condition only. No scheduled maintenance is required.

MARC 35

Switching Solutions For General Aviation



20 or 24 Pole
14Vdc or 28Vdc
FAA-PMA'd
Certified to 35K Feet

MARC 35 Switching Solutions

The AIS200-35 and AIS200-3514 are remote switching units that operate on 28 Vdc and 14 Vdc respectively. They allow a VOR NAV receiver and a GPS or other Long Range Navigation system to share a single HSI or CDI. The twenty poles of switching allows all the resolver lines and the steering lines to be switched simultaneously. Internal fail safe switching circuitry ensures that ILS steering is always displayed on the indicator should power be lost to the system or if an ILS frequency is selected in the NAV receiver. Annunciator outputs advise the pilot which system is being displayed on his HSI/CDI. The rugged construction of the AIS200-35 family, makes them ideal switching units for both fixed wing and helicopter operations.

AIS200-35 & AIS200-3514 Specifications

Size:	1.20" x 3.46" x 5.15"	
Weight:	8.0 oz	
Electrical:		
Voltage:	AIS200-35	28 Vdc
	AIS200-3514	14 Vdc
Current:	AIS200-35	20mA per relay (120mA all relays)
	AIS200-3514	40mA per relay (240mA all Relays)
Contact Rating:	2.0 Amps	
Operating Temp:	-40° to +70° C	
Altitude:	35,000 Ft.	
Shock:	12 G's in all axis	

The AIS240-35 is a multi-purpose switching unit , consisting of six, four pole relays for a total of 24 poles of switching capabilities. The relays are arranged in a group of four (16 poles) and two single relays (4 poles each). The relays can be activated by either a ground or 28 Vdc, maximizing installation flexibility. As with our whole family of switching units, the AIS240-35 uses gold plated dry contacts that are sealed in nitrogen filled cases.

AIS240 Specifications

Size:	1.20" x 3.46" x 5.15"
Weight:	8.0 oz
Electrical:	
Voltage:	28 Vdc
Current:	20mA per relay (120mA all relays)
Contact Rating:	2.0 Amps
Operating Temp:	-40° to +70° C
Altitude:	35,000 Ft.
Shock:	12 G's in all axis
Certification:	PMA, DO160c