

# SAC 7-35 Air Data Computer

## Putting Power In Your Navigation System



**Get The Most From Your Garmin GNS430/530**  
**Real Time Winds Aloft**  
**Density Altitude**  
**Outside Air Temperature**  
**Improved Roll Steering And Autopilot Capture**  
**ADS-B Interface to Mode S Transponders**



# SAC 7-35 Air Data Computer

## PERFORMANCE YOU CAN COUNT ON

The SAC 7-35 has set the Air Data Computer standard for General Aviation aircraft, combining the accuracy and performance demanded by today's integrated avionics systems. The addition of the SAC 7-35 will unlock the powerful features your new system is capable of providing to you. All with the quality and reliability you have come to expect from SANDIA aerospace.

In addition to the airdata capabilities the -01 version of SAC 7-35 provides interface compatibility between Garmin 400W/500W navigators and certain Mode S transponders for **ADS-B** operations.

## GET MORE FROM YOUR NAVIGATION SYSTEM

The new generation of integrated avionics have been designed to provide the pilot with a host of information to make his flying safer and more economical. Such information as real time **Winds Aloft** which aid the pilot in selecting the altitude that provides the best cruise performance. And with today's rising fuel costs, this is rapidly becoming a more and more important consideration. **Density Altitude** to help determine takeoff off distances and make those important go, no-go decisions, particularly at high altitude airports and those with short runways. Digital **Outside Air Temperature** simplifies temperature monitoring to determine when icing conditions may exist. **Fuel Flow** data allows you to continually monitor your fuel used and watch any changes in fuel consumption that may indicate engine problems.

## FOUR SYSTEMS IN ONE

A full featured **Air Data Computer** enhancing the utility of your navigation system. The SAC 7-35 provides all the performance of Airdata Computers costing thousands of dollars more. **Altitude In-Flight Monitoring** (AIM) alerts the pilot whenever the aircraft deviates more than 100' feet from a selected altitude. Certified **Altitude Encoder** that provides both Gilliam Grey Code for legacy transponders and RS 232 outputs for modern designs. With the addition of a fuel flow transducer(s) the SAC 7-35 supplies digital **Fuel Flow** information to navigation systems that have Fuel Flow displays.

## TECHNICAL SPECIFICATIONS

Electrical:		Altitude:	35,000' Max		
10-32 VDC					
1 Amp Max		Resolution:	Grey Code	100'	
Mechanical:			RS 232	10'	
4.87W x 5.62L x 1.89H			ARINC 429	10'	
1.2 Lbs		Accuracy:			
Inputs:		-1000'	to	5000'	±25'
ARINC 407 Synchro Heading		5001'	to	11000'	±30'
OAT		11001'	to	20000'	±35'
Pitot (Airspeed)		20001'	to	30000'	±50'
Static (Altitude)		30001'	to	35000'	±75'
Track, Mag Var & Ground Speed From On Board GPS					
5 Volt Pot Baro					
Fuel Flow, Pulse		Fuel Flow:			
GPS Position (-01 Version only)		Flow Rate	1-14400 GPH Per Side		
Air Speed:		K-Factor Range	500-130,000		
KTS:	40-450	ADS-B			
MACH:	0.1-.99		ARINC 743 Labels (-01 Version Only)		
Wind Speed:	0-200 Kts	Certification:			
Vertical Speed:	+/- 9999 Ft/min	TSO C88a, ETSO C88a			
	+/- 20000 On ARINC Bus	TSO C106, ETSO C106			
Air Temp:		DO160E			
Range:	-60C to +60C	DO178 Level C			
Accuracy:	+1.5°C	DO254			



www.sandia.aero

3700 Osuna Rd NE  
Suite 711  
Albuquerque, NM 87109  
R4-022010-1000



**SAC 7-35**

**Airdata Computer  
Installation Manual**



**SANDIA aerospace, Inc.**  
3700 Osuna Rd. NE, Suite 711  
Albuquerque, NM 87109  
[www.sandia.aero](http://www.sandia.aero)

305586-00

This document and the information contained herein is the proprietary data of SANDIA aerospace, Inc. No part of this document may be transmitted, reproduced, or copied in any form or by any means without the prior written consent of SANDIA aerospace, Inc. Due to SANDIA aerospace's continued product and quality improvement programs, information contained in this document is subject to change without prior notice.

Copyright 2009 SANDIA aerospace, Inc., All rights reserved. Printed in USA

Revision	Date	Description	Approval
A	20090205	DRN 309	John R. Fiala
B	20091113	ECN 3707	Leah Harrison
C	20100125	ECN 3720	Leah Harrison
D	20100323	ECN 3725	Leah Harrison
E	20140414	ECN 4007	Leah Harrison

# Table Of Contents

<b>Record of Revisions</b> .....	1
<b>Table of Contents</b> .....	2
<b>List of Illustrations</b> .....	2
<b>Section 1 - General Description</b>	
1.1 Introduction .....	4
1.1.1 Product Description .....	4
1.2 Technical Characteristics .....	5
1.2.1 Physical Characteristics .....	5
1.2.1.1 SAC 7-35 .....	5
1.2.1.2 STP 78 OAT Probe .....	5
1.2.2 Operational Characteristics .....	5
1.2.3 Operating Limitations .....	5
1.2.4 Outputs .....	7
1.2.4.1 RS 232 .....	7
1.2.4.1.1 RS 232 (A and B) Airdata Output .....	7
1.2.4.1.2 RS 232 (C and D) Corresponding Altitude Output .....	8
1.2.4.2 ARINC 429 High Speed Labels .....	8
1.2.4.3 Gillham Grey Code Output .....	8
1.2.4.4 AIM Output .....	8
1.2.5 Inputs .....	9
1.2.6 Certification .....	9
<b>Section 2 Installation Considerations</b>	
2.1 Introduction .....	12
2.2 Mounting Considerations .....	13
2.3 Cooling .....	13
<b>Section 3 Installation Procedures</b>	
3.1 General .....	14
3.2 Equipment Required .....	14
3.2.1 Equipment Supplied .....	14
3.2.2 Equipment Required But Not Supplied .....	14
3.3 Mounting Tray Installation .....	14
3.4 Static and Pitot Port Connection .....	16
3.5 OAT Probe Mounting and Connection .....	16
3.6 Electrical Installation .....	17
3.7 Fuel Flow Interconnect .....	18
3.8 Synchro Inputs .....	18
3.9 BARO Interface .....	18
3.10 Transponder Interconnect .....	19
3.11 AIM Interconnect .....	19
<b>Section 4 Configuration and Calibration</b>	
4.1 Setup for Configuration .....	24
4.2 Changing Configuration Parameters .....	24
4.3 Status Line Descriptions .....	26
4.3.1 Serial Port Settings .....	27
4.3.2 Airspeed Trim .....	27

## Table Of Contents Con't

4.3.3	Synchro Input Settings .....	27
4.3.4	Altitude Trim .....	28
4.3.5	BARO Setting Trim .....	28
4.3.6	Airspeed Cutoff .....	29
4.3.7	Fuel flow Configuration and K-factor .....	29
4.3.8	List Inputs .....	29
4.3.9	ARINC Mode .....	29
4.3.10	OAT Probe Trim .....	30
4.4	Continued Airworthiness .....	30

## List Of Illustrations

Figure 1-1	System Configuration Diagram .....	4
Figure 1-2	SAC 7-35 Environmental Qualification Form.....	10
Figure 1-3	OAT Probe Environmental Qualification Form.....	11
Figure 3-1	Mounting Tray Dimensions .....	15
Figure 3-2	SAC 7-35 Outline Dimensions .....	15
Figure 3-3	OAT Probe Dimensions .....	16
Figure 3-4	OAT Probe Mounting .....	17
Figure 3-5	Fuel Flow Interconnect .....	18
Figure 3-6	AIM Interconnect .....	19
Figure 3-7	Gilham Gray Code Interconnect w/ Most Popular Transponders .....	20
Figure 3-8	SAC 7-35 Interconnect Wiring Diagram .....	21
Figure 3-9	Front Panel Connector Location .....	23
Figure 4-1	6 Pin Din to Serial Interconnect .....	24
Figure 4-2	RS-232 Status Lines Setting .....	26
Figure 4-3	SAC 7-35 Configuration Mode - Unit Trim Status .....	26
Figure 4-4	SAC 7-35 Configuration Mode - Fuel Unit Status .....	26

# Section 1 General Description

## 1.1 INTRODUCTION

This manual describes the installation of the SANDIA aerospace SAC 7-35 Airdata Computer. It is intended for use by FAA certified repair stations to install the SAC 7-35 Airdata Computer and includes both the mechanical and electrical installation information for the SAC 7-35. Calibration, system configuration and checkout procedures are included. The installer should ensure that all functions are operating according to their intended purpose in their particular installation.

### 1.1.1 Product Description

The SAC 7-35 is a solid state -1000 to 35,000 foot airdata computer and altitude encoder. With the addition of a fuel flow transducer(s), the SAC 7-35 will also provide fuel flow data to systems capable of displaying that information. The SAC 7-35 provides five data outputs that allow it to interface with a wide range of transponders, TAWS, MFD's, Navigation Systems and a variety of other avionics products. The SAC 7-35 can also be installed for use in a variety of converter functions. Contact factory for more information.

- One ARINC 429 High Speed output, airdata and/or ADS-B.
- Two RS-232 airdata output ports (including fuel flow or ADS-B).
- Two RS-232 serial encoder outputs  
Note: All four of the RS-232 outputs can be individually configured to match the system(s) being interfaced.
- One Gillham Grey code output for legacy transponders.
- One SANDIA Altitude In-flight Monitoring (AIM) feature. With the addition of an optional panel mounted switch and annunciator the AIM mode will monitor and advise the pilot if the aircraft deviates from a selected altitude.

All calibration and configuration is accomplished via a lap top computer through the 6 pin Din connector on the front of the SAC 7-35.

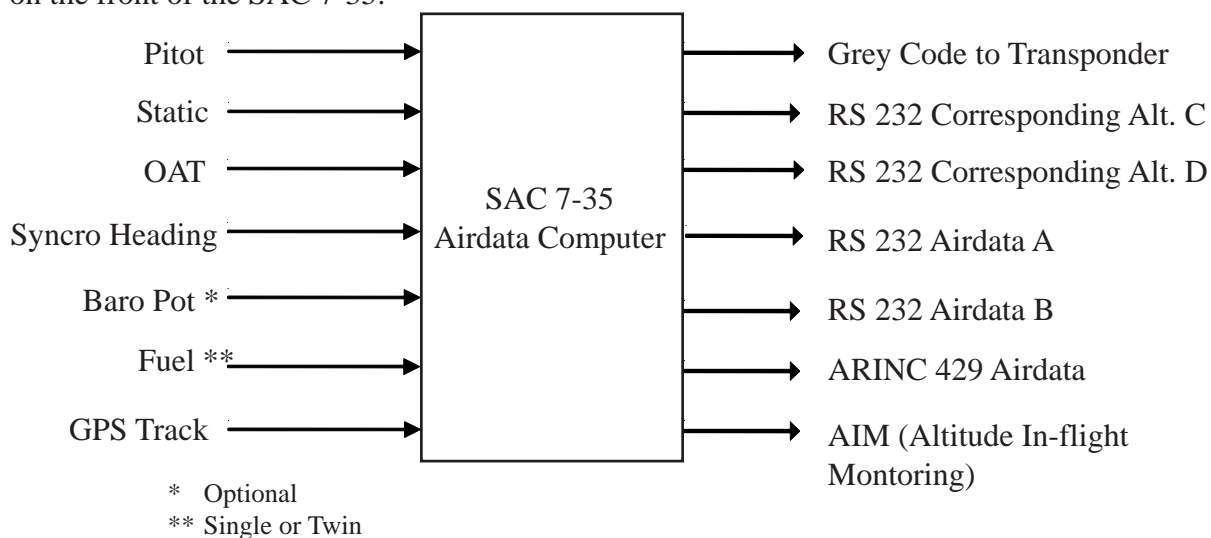

Figure 1-1  
System Configuration

## 1.2 TECHNICAL CHARACTERISTICS

### 1.2.1 Physical Characteristics

#### 1.2.1.1 SAC 7-35

Width: 4.87" (5.11" with mounting tray)  
 Height: 1.89" (2.35" with mounting tray)  
 Depth: 5.62" (5.62" with mounting tray)  
 Weight: 1.18 lbs. (1.39lbs. with mounting tray)

#### 1.2.1.2 STP 78 OAT Probe

See Fig 3.3 for Dimensions  
 Weight: .067 lbs

### 1.2.2 Operational Characteristics

Operating Temp.	-20° C to + 55° C	
Input Voltage:	11 - 32 Vdc	
Current	1.0 amp maximum with heater on	
Altitude Range	-1000' to 35,000'	
PressureAltitude Tolerance:	0'	+/- 25'
	2000'	+/- 25"
	3000'	+/- 30'
	4000'	+/- 25'
	5000'	+/- 25'
	8000'	+/- 30'
	11000'	+/- 35'
	14000'	+/- 40'
	17000'	+/- 45'
	20000'	+/- 50'
	30000'	+/- 100'
	40000'	+/- 125'
Resolution:	Grey Code	100'
	RS232	10'
	ARINC 429	1'
Density Altitude Accuracy	Pressure Alt	Correction Tolerance
	1000' - 18000' (P Alt)	250 ft. max.
Maximum Vertical Speed:	9,999 fpm Serial	
	20,000 fpm ARINC 429	
Accuracy	±1000 ft/min at ±20000 ft/min	
	±0300 ft/min at ±6000 ft/min	
	±0200 ft/min at ±4000 ft/min	
	±0100 ft/min at ±2000 ft/min	
	±0050 ft/min at ±1000 ft/min	
	±0045 ft/min below ±1000 ft/min	



Indicated Airspeed:	0-450 KTS 0.088-.999 MACH
---------------------	------------------------------

Accuracy	<u>Kts</u>	<u>Accuracy</u>
	50	5.0
	80	3.5
	100	2.0
	120	2.0
	150	2.0
	200	2.0
	250	2.4
	300	2.8
	350	3.2
	400	3.6
	450	4.0

MACH Number Accuracy	<u>MACH</u>	<u>Tolerance</u>
	0.3 to 0.4	0.012
	.0.5	0.010
	0.6	0.0075
	0.7-0.9	0.0050
	.95	0.0075

True Airspeed Accuracy	<u>ALT</u>	<u>IAS</u>	<u>TAS</u>	<u>TAS Accuracy</u>
	10000	50	53	6.6
	10000	100	105	3.0
	10000	200	211	3.3
	10000	300	314	4.6
	10000	400	416	5.9
	10000	450	467	6.5
	30000	50	80	10.1
	30000	100	160	4.6
	30000	200	315	5.2
	30000	300	460	6.9

## 1.2.2 Operational Characteristics con't

Wind Speed:	0-200 KTS
Accuracy	6.5 Kts
Wind Direction Accuracy	10 degrees
Air Temp:	
Range:	-60°C to +60°C
Accuracy	+1.5°C
Fuel Flow:	
Flow Rate:	1-14400 GPH
K-Factor Range	500-130,000
Outside Air Temperature	-60°C - +60°C
Accuracy	1.5°C

**The SAC 7-35 fuel flow conversion is limited to 2000 input pulses per second  
For example, do not install where the K factor and maximum fuel flow exceed:**

<b>500K — 14,400 gph</b>	<b>19700K — 365 gph</b>
<b>84600K — 85 gph</b>	<b>130000K — 55 gph</b>

## 1.2.3 Operating Limitations

**1.2.3.1** All functions of the SAC 7-35 meet the appropriate design assurance qualifications for a secondary system for airplanes in Class I, Class II and Class III in accordance with AC 23.1309-1D, Figure 2. The TSO authorization with the RTCA/DO178B software levels by functions are listed in Section 1.2.6

**1.2.3.2** The SAC 7-35 is for navigation information only and not for primary flight information.

**1.2.3.3** Fuel flow limited to 2000 input pulses per second.

## 1.2.4 Outputs

### 1.2.4.1 RS-232

#### 1.2.4.1.1 RS-232 (A & B) Airdata

The airdata outputs supported by the SAC 7-35 are Garmin Z-message, Garmin-G and King D. Each of these output formats work with 'Aviation' format input.

The SAC 7-35 will also interface to a Garmin ADS-B serial output on port -B at 9600 baud. When connected to ADS-B input no serial data is output on port-B.

Baud Rate	Installation Configurable to 1200, 9600, 19200 or 38400
Data Bits	8
Stop Bit	1
Parity	None
Output Rate:	1 +/- .2 seconds
Altitude Resolution	10"
Airspeed Resolution	1 Kt

### 1.2.4.1.2 RS 232 (C & D) Corresponding Altitude

The SAC 7-35 supports Garmin and Garmin AT RS232 Corresponding Altitude formats.

Baud Rate	Installation Configurable to 1200, 9600, 19200 or 38400
Data Bits	8
Stop Bit	1
Parity	None
Output Rate:	1 +/- .2 seconds
Altitude Resolution	10"

### 1.2.4.2 ARINC 429, High Speed

If Selected, the following 100 kbit/sec (High Speed) ARINC 429 Airdata Labels are transmitted by the SAC 7-35:

<u>Label</u>	<u>Parameter</u>	<u>Units</u>	<u>Repeat Rate</u>	<u>Range</u>	<u>Resolution</u>
162	Density Altitude	Feet	62.5ms	131072	1
203	Pressure Altitude	Feet	62.5ms	131072	1
204	Baro Altitude	Feet	62.5ms	131072	1
205	MACH Number	Mach	62.5ms	4.0	6.25E-5
206	IAS	Knots	62.5ms	1024	0.0625
210	True Airspeed	Knots	62.5ms	2048	0.0625
211	Total Air Temp	degC	500ms	512	0.25
212	Altitude Rate	ft/min	62.5ms	32768	16
213	Static Air Temp	degC	500ms	512	0.25
235	Baro Setting	InHg	62.5ms	39.999	0.001
244	Total Fuel Flow	Lb/hr	62.5ms	32768	0.5
315	Wind Speed	Knots	500ms	256	1
316	Wind Direction	Deg True	500ms	360	0.05
320	Magnetic Heading	Deg Mag	62.5ms	360	0.0055
347	L/R Fuel Flow	Lb/hr	62.5ms	32768	0.5

(Alternates L/R)

If selected, the following 100 kbit/sec (High Speed) ARINC 429/743 ADS-B Labels are transmitted by the SAC 7-35 (-01 version only):

<u>Label</u>	<u>Parameter</u>	<u>Units</u>	<u>Repeat Rate</u>	<u>Range</u>	<u>Resolution</u>	<u>Data bits</u>
103	Ground Track	Degrees	as received	180	0.0055	15
110	Latitude	degrees	as received	180	1.7E-4	20
111	Longitude	degrees	as received	180	1.7E-4	20
112	Ground Speed	knots	as received	4096	0.125	15
120	Fine Latitude	degrees	as received	1.7E-4	8.4E-8	11
121	Fine Longitude	degrees	as received	1.7E-4	8.4E-8	11
130	Horiz Prot Level	nm	1 sec	16	1.22E-4	17
133	Vert Prot Level	feet	1 sec	32768	0.125	18
136	Vert. Fig of Merit	feet	1 sec	32768	0.125	18
165	Vert Velocity	fpm	as received	32768	1	15
166	North/South Velocity	knots	as received	4096	0.125	15
174	East/West Velocity	knots	as received	4096	0.125	15
247	Horiz Fog of Merit	nm	1 sec	16	6.10E-5	18
273	GPS Status	discr	1 sec	discr	discr	discr
335	Track Angle Rate	deg/s	as received	32	0.015625	11
370	GPS Height	feet	as received	131072	0.125	20

### 1.2.4.3 Gillham Grey Code Outputs

- a. 10 Bits available: D4, A4, A2, A1, B4, B2, B1, C4, C2, C1
- b. Bit On Impedance: Less than 5 ohms
- c. Bit Off Leakage: Less than 10uA
- d. Maximum Current per bit: 20 mA
- e. Minimum working current: 10 uA
- f. Maximum voltage per bit: 50V
- g. Minimum working voltage: 5V
- h. Bit update rate: Less than 250 mS
- i. Minimum strobe switching bandwidth: Greater than 10kHz

### 1.2.4.4 AIM Outputs

Maximum Lamp Current: 80 mA

Maximum off Voltage: 50V

### 1.2.5 Inputs

Static Pressure	-1000 to 35,000 feet
Pitot Pressure	0 to 450 Kts
Outside Air Temp (OAT)	-60° to +60° C
Heading	ARINC 407 Syncro (line voltage 11.8 Vrms) Leg H 10 KΩ Leg X 17 KΩ Leg Y 17 KΩ
Fuel Flow	0 to 14400 GPH (2000 pulses/sec max)
K-factor	500-130000
Baro	0 to +5Vdc Baro Pot
AIM Pushbutton	Active Low with Internal Pull Up
Strobe	From On board Transponder

### 1.2.6 Certification

- TSO C88a (Encoder)
- TSO C106 (Airdata Computer)
- ETSO C88a
- ETSO C106
- Hardware DO 160E
- Software DO 178B Level C
- Complex Hardware DO-254 Level C

“The conditions and test required for TSO approval of this article are minimum performance standards. It is the responsibility of those desiring to install the article either on or within a specific type or class of aircraft to demonstrate that the aircraft installation conditions are within the TSO standards. The article may be installed only if installation of the article is approved by the Administrator.”

## Environmental Qualification Form for the SAC 7-35 Airdata Computer

**NOMENCLATURE:** SAC 7-35, Airdata Computer

**TYPE/MODEL/PART NO:** SAC 7-35 / 305548-00

**TSO NUMBER:** C88a, C106

**MANUFACTURER'S SPECIFICATION AN/OR OTHER APPLICABLE SPECIFICATION:**

SAC 7-35 INSTALLATION MANUAL P/N 305586-00

QUALIFICATION TEST PLAN, 901000-QTP

**MANUFACTURER:** SANDIA AEROSPACE

**ADDRESS:** ALBUQUERQUE, NM 87109

**REVISION & CHANGE NUMBER OF DO-160:** REV E

Conditions	Section	Description
Temperature and Altitude	4.00	Category C4
Low Temperature	4.5.1	-20C Operation Cold Temp
High Temperature	4.5.2 & 4.5.3	+55C Operating High Temp -40C Short Time OP Low Temp +55C Short Time Op High Temp -55C Ground Survival Lo +85C Ground Survival High
	4.5.4	Test Not Applicable
In-Flight Loss of Cooling Altitude Decompression Overpressure	4.6.1 4.6.2 4.6.3	35,000 feet Test Not Applicable Test Not Applicable
Temperature Variation	5.0	Tested to Category C 2C/Min
Humidity	6.0	Tested to Category A
Operational Shock and Crash Safety	7.0	Test to Category A, Aircraft Type 5. Random Orientation
Vibration	8.0	Tested to Categories S & U2, Aircraft Zone 2 using vibration curves M, F & F1
Explosion	9.0	Equipment identified as Category X, no test performed
Waterproofness	10.0	Equipment identified as Category X, no test performed
Fluids Susceptibility	11.0	Equipment identified as Category X, no test performed
Sand and Dust	12.0	Equipment identified as Category X, no test performed
Fungus	13.0	Equipment identified as Category X, no test performed
Salt Spray	14.0	Equipment identified as Category X, no test performed
Magnetic Effect	15.0	Equipment is category Z < 0.3M Deflection
Power Input	16.0	Tested to Category B
Voltage Spike	17.0	Tested to Category A
Audio Frequency Susceptibility	18.0	Tested to Category B
Induced Signal Susceptibility	19.0	Tested to Category BC
Radio Frequency Susceptibility	20.0	Tested to Category TT
Radio Frequency Emission	21.0	Tested to Category M
Lightning Induced Transient Susceptibility	22.0	Equipment identified as Category X, no test performed
Lightning Direct Effects	23.0	Equipment identified as Category X, no test performed
Icing	24.0	Equipment identified as Category X, no test performed

Figure 1-2  
SAC 7-35 Environmental Qualification Form

## Environmental Qualification Form for the STP 78 OAT Probe

**NOMENCLATURE:** Outside Air temperature Probe

**TYPE/MODEL/PART NO:** STP 78 OAT Probe /305561-01

**TSO NUMBER:** C88a, C106

**MANUFACTURER'S SPECIFICATION AN/OR OTHER APPLICABLE SPECIFICATION:**

SAC 7-35 INSTALLATION MANUAL P/N 305586-00

QUALIFICATION TEST PLAN, 901000-QTP

**MANUFACTURER:** SANDIA AEROSPACE

**ADDRESS:** ALBUQUERQUE, NM 87109

**REVISION & CHANGE NUMBER OF DO-160:** REV E

CONDITIONS	SECTION	DESCRIPTION OF TESTS CONDUCTED
Temperature and Altitude	4.0	Category C2
Low Temperature	4.5.1	-55C Operating Low Temp
High Temperature	4.5.2 & 4.5.3	+70C Operating High Temp -55C Short Time Op Low Temp +70C Short Time Op High Temp 55C Ground Survival Low +85C Ground Survival High
In-Flight Loss of Cooling	4.5.4	Test not Applicable
Altitude	4.6.1	35,000 feet
Decompression	4.6.2	Test not Applicable
Overpressure	4.6.3	Test not Applicable
Temperature Variation	5.0	Tested to Category A 10C/Min Tested separately from SAC 7-35
Humidity	6.0	Tested to Category C Tested separately from SAC 7-35
Operational Shock and Crash Safety	7.0	Test to Category A, Aircraft Type 5. Random Orientation
Vibration	8.0	Tested to Categories S & U2, Aircraft Zone 1 using vibration curves M, F & F1
Explosion	9.0	Equipment identified as Category X, no test performed
Waterproofness	10.0	Equipment identified as Category X, no test performed
Fluids Susceptibility	11.0	Equipment identified as Category X, no test performed
Sand and Dust	12.0	Equipment identified as Category X, no test performed
Fungus	13.0	Equipment identified as Category X, no test performed
Salt Spray	14.0	Equipment identified as Category X, no test performed
Magnetic Effect	15.0	Equipment is category Z
Power Input	16.0	Equipment identified as Category X, no test performed
Voltage Spike	17.0	Equipment identified as Category X, no test performed
Audio Frequency Susceptibility	18.0	Tested to Category B
Induced Signal Susceptibility	19.0	Tested to Category BC
Radio Frequency Susceptibility	20.0	Tested to Category TT
Radio Frequency Emission	21.0	Tested to Category M
Lightning Induced Transient Susceptibility	22.0	Equipment identified as Category X, no test performed
Lightning Direct Effects	23.0	Equipment identified as Category X, no test performed
Icing	4.0	Equipment identified as Category X, no test performed

Figure 1-3  
OAT Probe Environmental Qualification Form

# Section 2 Installation Considerations

## 2.1 INTRODUCTION

The SAC 7-35 Airdata Computer enhances installations that include GPS, TWAS, Moving Map Displays and other avionics that can utilize airdata information. Additionally, the SAC 7-35 is TSO'd and ETSO'd as an Altitude Encoder for use with transponder systems. The SAC 7-35 provides standard Gillham Grey Code output on its 15 pin connector (P-101) for use with legacy transponders. Two independent RS232 corresponding altitude outputs are provided on the 25 pin connector (J-100). The RS 232 outputs can be used on new generation transponders that accept RS-232 altitude format or other systems that require corresponding altitude. The P-101 Grey Code connector follows the standard interconnect format used by most encoder manufacturers. By following this convention, upgrading to the SAC 7-35 is made easier. If an existing encoder is being replaced, it is important to check the wiring information before plugging the existing connector into the SAC 7-35.

Two RS232 Airdata and one high-speed ARINC 429 airdata outputs are available from the SAC 7-35.

Fuel flow data is supported by the SAC 7-35 if pulse type fuel flow transducer(s) are mounted in the aircraft's fuel lines. The SAC 7-35 only accepts pulse type fuel information such as that provided by Flow Scan transducers or through the use of an appropriate converter. If the aircraft is equipped with a Flow Scan transducer(s) the SAC 7-35 can parallel off the signal line. The SAC 7-35 must be configured with the transducer(s) K-factor number.

If the aircraft has an altimeter with a 5 VDC baro pot, the SAC 7-35 can use this to provide corrected altitude output on the ARINC 429 bus. The Garmin-Z output format does not support Baro Correction information. But, when the baro input is available the data will be included in the King-D and Garmin-G serial RS-232 airdata outputs.

The SAC 7-35 also incorporates SANDIA aerospace's exclusive Altitude In-flight Monitoring (AIM) feature that advises pilots if they deviate from their selected altitude by more than one hundred feet. The AIM feature can be installed by adding a switch and annunciators to the aircraft panel.

The SAC7-35 accepts (five wire HSI) heading input in ARINC 407 format. Heading, GPS ground speed and track inputs are required in order for the SAC 7-35 to calculate winds aloft.

The SAC 7-35 does not require warm up unless the outside temperature is below 20 degrees C. When warm up time is required, the internal heater is generally capable of warming the SAC 7-35 from -55 degrees C to operating temperature in less than one minute.

Systems configuration and calibration is accomplished using an installer supplied computer. The SAC 7-35 is connected to the computer's 9 pin RS 232 port from the 6 pin DIN connector located on the front panel of the SAC 7-35.

## 2.2 MOUNTING CONSIDERATIONS

The SAC 7-35 can be mounted in any orientation, either inside or outside the pressure vessel. Mounting location should be chosen to minimize the static pressure line length from the SAC 7-35 to the altimeter. Be sure to allow an ample service loop on the cable to allow for calibration of the SAC 7-35. You'll notice that the SAC 7-35 mounting tray has the same hole pattern as the SAE 5-35 encoder. This will simplify installations where the SAE 5-35 is being upgraded with the SAC 7-35.

**CAUTION: DO NOT mount the SAC 7-35 in the direct airstream or near either the hot or cold air ducts.**

The STP 78 Outside Air Temperature (OAT) probe is supplied with the SAC 7-35. It should be mounted in a location away for the engine exhaust or other area that prevent it from accurately measuring outside air temperature. The OAT probe should never be mounted on a dark painted surface. This will cause errors in the OAT measurement.

**CAUTION: DO NOT mount the Outside Air Temperature (OAT) probe near the aircraft exhaust or prop wash, dark surfaces, transmitting antennas or cabin heaters.**

## 2.3 COOLING

The SAC 7-35 does not require external cooling.



# Section 3 Installation Procedures

## 3.1 GENERAL

The SAC 7-35 is supplied with a mounting tray and crimp type mating connectors. It is important that the proper crimping tools and techniques be observed in attaching wires to the mating connectors. Failure to do so could result in a failure in the connection and cause intermittent or non operation of the SAC 7-35.

## 3.2 EQUIPMENT REQUIRED

### 3.2.1 Supplied

SAC 7-35 System	705548-XX
Includes: SAC 7-35 Airdata Computer	305548-XX
SAC 7-35 Installation Manual	305586-00
SAC 7-35 Installation Kit, Electrical	305588-00
15 Pin Connector Hood	305208
2 each 25 Pin Connector Hoods	305437
25 Pin Female Connector w/Crimp Pins	305583
25 Pin Connector w/Crimp Sockets	305720
15 Pin Male Connector w/Crimp Pins	305721
SAC 7-35 Installation Kit, Mechanical	305589-00
Mounting Tray	305557
Knurled Hold-down Nut	305558
STP 78 OAT Probe	305561-91
OAT Probe Installation Kit	305595-00
Mounting Nut	305560-03
Mounting Lock Washer	305050-10
Fiber Shoulder Washer	305587-03
Flat Fiber Mounting Washer	305581-04
9 pin RS 232 to 6 pin DIN adapter cable	305580

### 3.2.2 Required But Not Supplied

Number 6-32 Mounting Screws, 3 or 4 depending on your selected mounting option.

Static Port Fitting

Pitot Port fitting

## 3.3 MOUNTING TRAY INSTALLATION

The mounting tray is mounted to the airframe using either three or four number 6-32 screws. The mounting hole pattern for the SAC 7-35 mounting tray contains five holes. For new installations, it is recommended that the four corner holes be used to mount the SAC 7-35 tray. The fifth hole has been added to facilitate upgrades from some manufactures encoders. Refer to the SAC 7-35 tray dimensions in Figure 3-1 to determine if the hole pattern of the removed system match the hole pattern of the SAC 7-35 mounting tray.

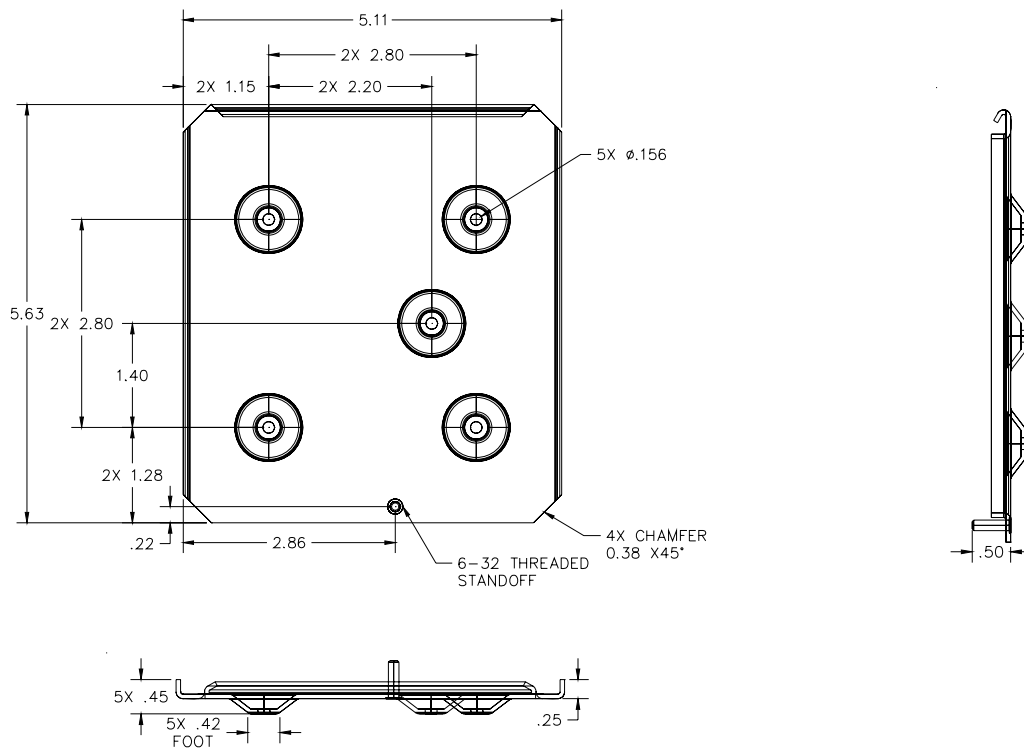

Figure 3-1  
Mounting Tray Dimensions

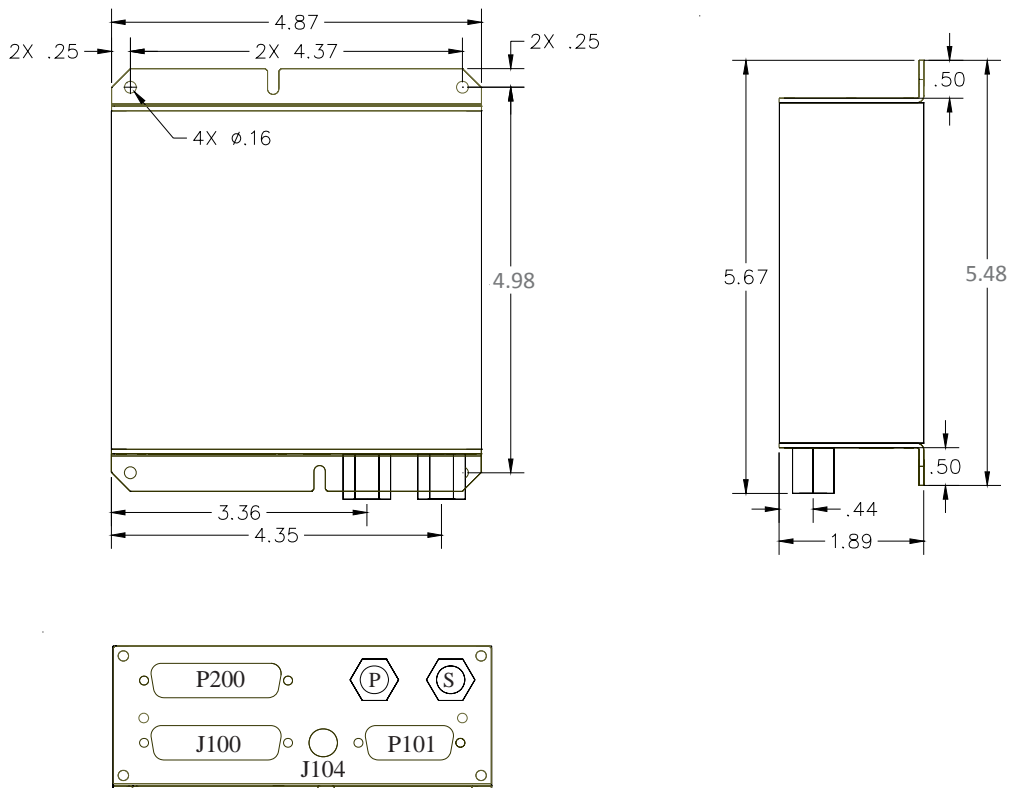

Figure 3-2  
Unit Outline Dimensions

### 3.4 STATIC AND PITOT PORT CONNECTION

Standard 1/8 - 27 NPT brass fittings are provided on the front plate of the SAC 7-35 for attaching to the aircraft static and pitot systems. An adapter may be used to convert these to match the aircraft static and pitot plumbing. When attaching the mating fittings, make sure that they are secure and free from leaks that can induce errors in the static and pitot systems. To reduce the likelihood of the brass fitting rotating while installing the static line, a “D” shaped hole is used to mount the brass fittings into the front panel. Upon completion of the installation of the SAC 7-35, a Case Leak test is to be performed per FAR Part 43 Appendix E.

**NOTE: Since significant force can be applied to the SAC 7-35 during static and pitot fitting installation, dual wrench techniques are always recommended to avoid damage to the airdata computer.**

### 3.5 OUTSIDE AIR TEMPERATURE (OAT) PROBE INSTALLATION

The SAE 7-35 is supplied with the STP 78 OAT probe P/N 305561-91. Avoid mounting the OAT probe in or near prop airstream, engine or heater exhaust, transmitting antennas or on dark painted surface. Failure to do so will result in improper OAT readings. The OAT probe requires a 7/16” hole be drilled in the skin of the aircraft. The installer should consider fabricating an appropriate doubler plate in accordance with accepted installation practices as outlined in AC 43.13-1B. Skin thickness including doubler should be a minimum of 0.050” and a maximum of 0.188”. See figure 3-4 for mounting details. The OAT probe comes with a three wire pigtail approximately 2 feet in length. The installer can cut this cable to length or extend it by adding additional wire. Make sure that any connections are away from areas that can accumulate water or chemicals.

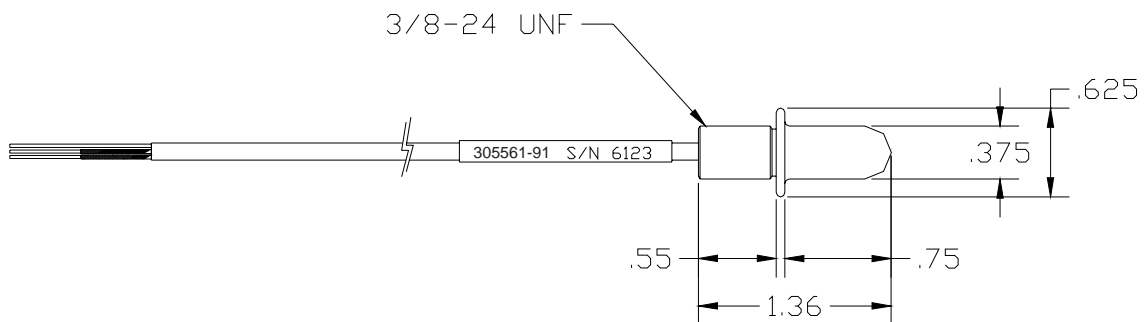

Figure 3-3  
STP 78 OAT Probe Dimensions

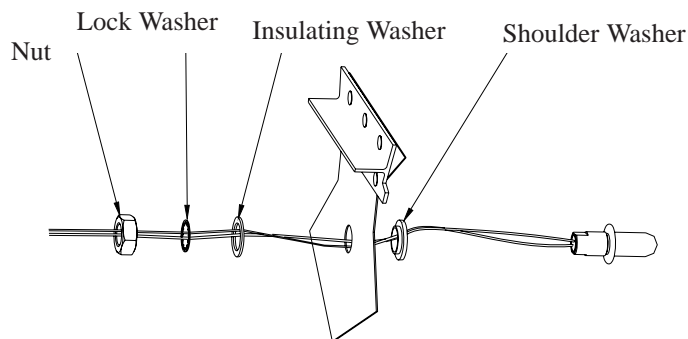

Figure 3-4  
STP 78 OAT Probe Mounting

### 3.6 ELECTRICAL INSTALLATION

The SAC 7-35 is designed to operate from 11-32 Vdc without any special wiring considerations. Power can be supplied from the aircraft buss through a 2 Amp circuit breaker. Since the SAC 7-35 is TSO'd as an encoder, power can also be supplied from the onboard transponder. If power is supplied from the transponder, the SAC 7-35 and it's airdata functions will not operate if the transponder is turned off or removed from the aircraft.

**Installation to be in accordance with FAA  
AC 43.13-1B**

**NOTE: If the power source for the SAC 7-35 is from the on board transponder, the SAC 7-35 and it's airdata outputs will not be available if the transponder is turned off or removed from the aircraft.**

SAE document AS8003 *Minimum Performance Standard for Automatic Pressure Altitude Code Reporting Equipment* states that “a means shall be incorporated in the equipment to indicate the loss of electrical power or the effect thereof, unless the electrical power to operate the code generating equipment is supplied by an ATC Transponder which also supplies an indication of this power loss.” The two power pins 14 and 8 on P101 are internally connected in the SAC 7-35. Only one of these connections is necessary to supply power to the unit. The unused connection can be used to drive a panel-mounted indicator if desired.

The SAC 7-35 uses crimp type Sub-D connectors with screw lock assemblies. The proper crimp tool for use with machined Sub-D connector pin and sockets is required to ensure that the wire and connector have good electrical and mechanical bond.

### 3.7 FUEL FLOW INTERCONNECT

The SAC 7-35 accepts Fuel Flow from a pulse type fuel flow transducer, such as the Flow Scan 201 series, that outputs flow rates from 0-14400 GPH (2000 pulses/sec max). The SAC 7-35 can use existing Fuel Flow transducers that are already installed in the aircraft, if they are of the proper type. The signal and ground wire(s) can be paralleled into the SAC 7-35 (in this case, power should not be connected from the SAC 7-35). Fuel Flow signals are inputted on J100.

Fuel Flow transducers should never have power connected to two sources. This will cause damage to one of the devices.

**Note: Use Shielded wires grounded at SAC 7-35 end only.**

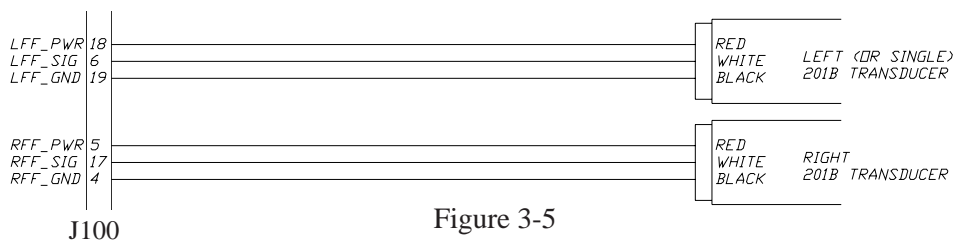

Figure 3-5  
Fuel Flow Interconnect

### 3.8 SYNCHRO INPUTS

The heading synchro heading inputs follow ARINC 407 standard. There are five input signals; SYNC-VX, SYNC-VY, SYNC VZ, SYNC VH and SYNC VC. They are available from a slaved compass system with a boot strap output.

**Note: SYNC VC is grounded.**

### 3.9 BARO INTERFACE

If the aircraft is so equipped, the SAC 7-35 will accept a Baro correction input from the onboard altimeter. The Baro signals are BARO Pwr and Baro Sig. The baro setting input is a 5Vdc potentiometer which is included in several common altimeters. The BARO PWR signal is an accurate 5Vdc output that energizes the potentiometer in the altimeter. The BARO SIG is the voltage on the wiper of the pot. Representative baro setting versus voltages are:

<u>InHG</u>	<u>Volts</u>
28.10	0.484
28.50	1.029
29.00	1.701
29.50	2.364
29.92	2.916
30.06	3.098
30.50	3.664
30.90	4.174
30.99	4.288

**Note: If Baro Pot is not connected, Ground Pin 7 on P200**

### 3.10 TRANSPONDER INTERCONNECT

All transponder functions including the Gilham Grey Code output are on the 15 pin connector P101. The two RS232 digital outputs for new generation transponders and other avionics that require corresponding altitude are on P100 pin 9 & 10 and 21 & 22. The two RS-232 corresponding outputs that can be independently configured. The Grey code output is enabled by grounding the Strobe line on J101 pin 6. There are three methods to accomplish this grounding.

1. Permanently ground this line.
2. The transponder provides a switched ground enable signal.
3. The transponder provides a strobe-ground enable signal.

The SAC 7-35 is compatible with all three systems. Refer to the appropriate transponder installation manual for detail. Interconnect information for the most popular transponders can be found in Figure 3-7. For other makes of transponders, refer to the manufactures installation manual.

**Note: The RS232 serial data outputs are not affected by the Strobe/Enable input signal.**

### 3.11 AIM INTERCONNECT

The SAC 7-35 incorporates SANDIA's AIM (Altitude Inflight Monitoring) feature that will alert the pilot any time he deviates from his selected altitude by 100' or more. The AIM functions are on P100, pins 1, 2 and 14. A momentary pushbutton and two annunciators are required for this function.

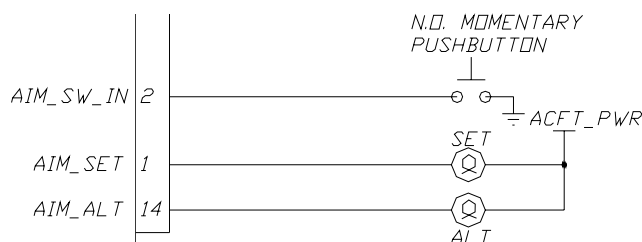

Figure 3-6  
AIM Interconnect

Notes:

1. Maximum lamp current 80mA
2. AIM switch is a momentary contact
3. If the AIM function uses annunciator lamps provided by the installer, they should be appropriately labeled. The lamp connected to pin 14 should be labeled 'ALT' and the lamp connected to pin 1 should be labeled 'SET'.
4. Sandia recommends a Green lamp for the SET Annunciator and Amber for the ALT Annunciator

SAE5-35 J4	Function	Bendix TPR2060	Bendix TR641A/B	Cessna RT359T, RT459A, RT859A	Garmin GTX32X Series	Garmin GTX330, GTX33 (J3301)	Honeywell KT7071 (Connector JKT701)	Honeywell KT76A/78A	Honeywell KXP	Narco AT50/A, AT150	Narco AT5, AT6/A	UPS/AT SL70	Wilcox 1014A
1	D4	No Connection	N	10	18	11	8	No Connection	V	No Connection	No Connection	35	C
2	A1	4	A	14	3	2	M	M	G	7	2	13	k
3	A2	6	B	13	5	4	K	K	H	6	4	31	c
4	A4	8	C	15	6	5	J	J	J	8	8	12	W
5	B1	9	D	19	9	7	E	E	K	12	9	33	T
6	Strobe/Enable	Aircraft Ground	Aircraft Ground	11	Aircraft Ground	Aircraft Ground	Aircraft Ground	Aircraft Ground	Aircraft Ground	5	12	Aircraft Ground	Aircraft Ground
7	Ground	Aircraft Ground	Aircraft Ground	Aircraft Ground	Aircraft Ground	Aircraft Ground	Aircraft Ground	Aircraft Ground	Aircraft Ground	Aircraft Ground	Aircraft Ground	Aircraft Ground	Aircraft Ground
8	Aircraft Power	Note 1	Note 1	9 or per Note 1	Note 1	Note 1	Note 1	Note 1	Note 1	18 or per Note 1	13 or per Note 1	Note 1	Note 1
9	B2	10	E	17	11	9	C	C	L	10	10	14	L
10	B4	11	F	16	12	10	B	B	M	9	11	32	D
11	C1	3	H	21	10	8	D	D	P	14	1	16	P
12	C4	7	K	20	7	6	H	H	S	13	5	15	Z
13	C2	5	J	18	4	3	L	L	R	11	3	34	f
14	Aircraft Power	Note 1	Note 1	Note 1	Note 1	Note 1	Note 1	Note 1	Note 1	Note 1	Note 1	Note 1	Note 1
15	Aircraft Ground	Aircraft Ground	Aircraft Ground	Aircraft Ground	Aircraft Ground	Aircraft Ground	Aircraft Ground	Aircraft Ground	Aircraft Ground	Aircraft Ground	Aircraft Ground	Aircraft Ground	Aircraft Ground

Figure 3-7  
Gilham Gray Code Interconnect w/ Most Popular Transponders

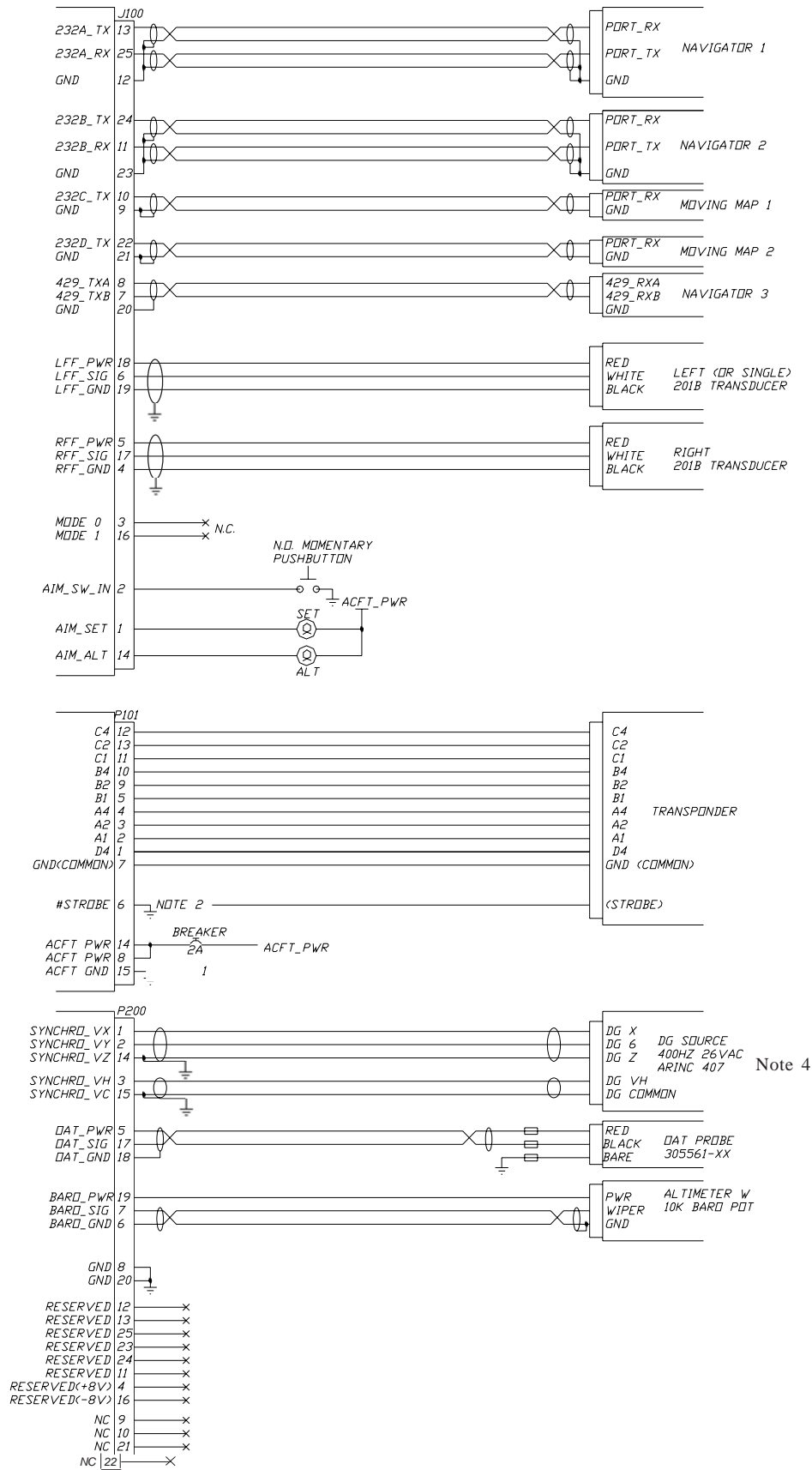

Figure 3-8  
SAC 7-35 Interconnect Wiring Diagram



## Installation Notes:

Note 1: All wires are 24 AWG or larger unless otherwise noted.

Note 2: Ground Strobe output to P101-6 if not required for transponder.

Note 3: Fuel Flow transducers should never have power connected to two sources. This will cause damage to one of the devices.

Note 4: Depending upon the DG source output levels, a Static Inverter such as the Mid-Continent MD26-XX or equivalent may be required.

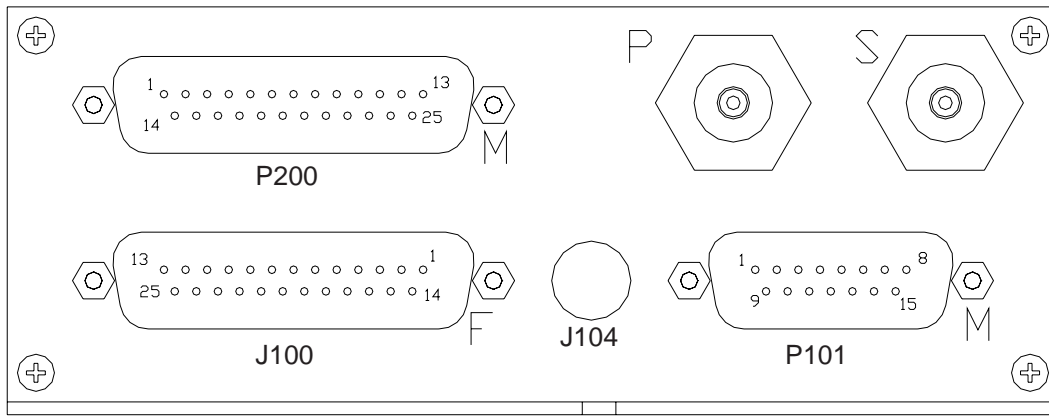

Figure 3-9  
Front Panel Connector Location

J100		P200		P101		
13	RS232A TX	} RS 232A Airdata	1	Syncro VX	12	C4
25	RS232A RX		2	Syncro VY	13	C2
12	Gnd		14	Syncro VZ	11	C1
24	RS232B TX	} RS232B Airdata	3	Syncro VH	10	B4
11	RS232B RX		15	Syncro VC	9	B2
23	Gnd		5	OAT Pwr (+5V)	5	B1
10	RS232C TX	} RS232C Corresponding Alt	17	OAT Signal	4	A4
9	Gnd		18	OAT Return	3	A2
22	RS232D TX		19	BARO Pwr	2	A1
21	Gnd	Note 2	7	BARO Signal	1	D4
8	ARINC 429 TXA		6	BARO Return	7	Gnd
7	ARINC 429 TXB		12	Reserved	Note 3 — 6	Strobe
20	Gnd	13	Reserved	Note 1 □ 14		A/C Pwr
18	Left Fuel Flow Pwr	25	Reserved			8
6	Left Fuel Flow Signal	23	Reserved		15	A/C Gnd
19	Left Fuel Flow return	24	Reserved			
5	Right Fuel Flow Pwr	11	Reserved			
17	Right Fuel Flow Signal	9	N/C			
4	Right Fuel Flow Return	10	N/C			
3	Configuration Mode	21	N/C			
16	N/C - Reserved	22	N/C			
15	Oper (Unit Valid)	N/C				
2	AIM SW In	Note 1 □ 8	8	Gnd		
1	AIM SET		20	Gnd		
14	AIM ALT	4	Reserved (+8V)			
		10	Reserved (-8V)			

- Note 1 Internally Connected  
 Note 2 Ground Pin 7 if Baro Pot not connected  
 Note 3 Ground Strobe Pin is not required by Transponder

Figure 3-8  
SAC 7-35 Pinout

# Section 4 Configuration and Calibration

## SYSTEM CONFIGURATION

### 4.1 Setup for Configuration

The SAC 7-35 has a configuration mode allowing it to be configured for varying aircraft equipment. A DIN to 9-pin serial port adapter can be plugged into the configuration connector, J104 (a 6 pin Din to 9 Pin serial adapter cable, SANDIA upart number 305580, is supplied with each unit). The SAC 7-35 automatically senses if a computer is plugged into this connector and will enter configuration mode on power up. The unit will set the RS232B port for system configuration mode. Disconnect J100 from the SAC 7-35 during this procedure to prevent any possible interference on the RS232 lines. This port will have the following parameters: Baud: 9600 Bits: 8 Stop bits: 1 Parity: None

**Note: You can purchase a 9 Pin to Din adapter locally, use the supplied Sandia Adapter or build your own using the diagram in Fig. 4-1**

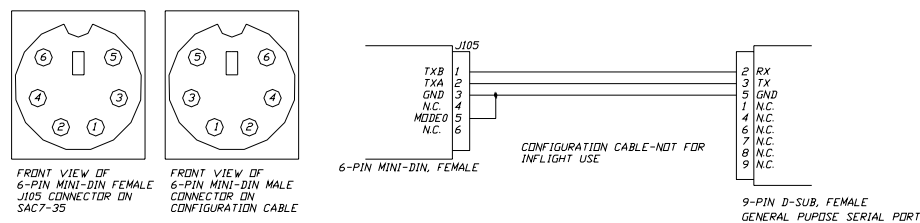

Figure 4-1  
6 Pin Din to Serial Interconnect

**SAC 7-35 J100 MUST be disconnected during configuration and calibration procedures to eliminate possible interference on the RS 232 lines.**

### 4.2 Changing Configuration Parameters

When first connecting the SAC 7-35, the installer will be presented with the following menu:

SANDIA AEROSPACE SAC 7-35 305548-XX Copyright 2004-2009  
SW PN: 901001-0C-00 SW VER: XX.X

CONFIGURATION:

Serial > K:9600 G:38400 S:1200 E:19200 Mode>> IAS\_Cutoff=40 Arinc=A DASH -00  
Trim >> Alt:-1270:1270 IAS:0:10 Baro:-1.27:1.27 OAT:0:0 Hdg:000:0  
Fuel >> K=130000:500 Os delay 6.02lb/g

CONFIGURATION MENU:

- |                     |                    |                 |                     |
|---------------------|--------------------|-----------------|---------------------|
| 1. PortA Format     | 2. PortA Baud      | 3. PortB Format | 4. PortB Baud       |
| 5. PortC Format     | 6. PortC Baud      | 7. PortD Format | 8. PortD Baud       |
| 9. Airspeed Trim    | a. Altitude Trim   | b. Baro Trim    | c. Airspeed Cut off |
| d. Fuel Start Delay | e. Fuel Engine Cnt | f. Fuel Density | g. Reserved         |
| h. Syncro CW/CCW    | i. Syncro Index    | j. Reserved     | k. Fuel Kfactor     |
| l. List Inputs      | m. Mode Select     | n. Reserved     | o. Oat Trim         |
| x. Exit             |                    |                 |                     |

**Note: The SAC 7-35 must be reset by cycling power, after configuration is completed**

The configuration menu presents all the adjustable parameters. To change a parameter enter a single character followed by return. For example:

Select an Option to Configure: 1<enter>

Select the number 1 and press Enter. This would change the Port1 Format parameter. The prompt will then change to:

1. Garmin Z
2. King D
3. Garmin G
4. ADS-B
5. Disabled

Select a Navigation System:

Then enter a selection (or value) followed by enter. For Example:

Select a Navigation System: 1<enter>

The status lines will show the new configuration. (Garmin-Z is represented by a Z):

Serial > Z:1200 G:38400 S:1200 E:19200 Mode>> IAS\_Cutoff=40 Arinc=A DASH -00

Trim >> Alt:-1270:1270 IAS:0:10 Baro:-1.27:1.27 OAT:.0:.0 Hdg:000:0

Fuel >> K=130000:500 Os delay 6.02lb/g

After all the configuration parameters are programmed, select x<enter> to store the parameters. Press Enter again to record changes or Escape to go back. The status lines should be recorded for future reference. Then the DIN to Serial cable adapter removed. Upon a power cycle, the new parameters will be set into the SAC 7-35.

**Note: Record and save the Status lines for future use. They can be use to reprogram the unit should service or replacement be required.**

SAC 7-35 S/N \_\_\_\_\_ A/C N# \_\_\_\_\_

Serial > \_\_\_ : \_\_\_ : \_\_\_ : \_\_\_ : \_\_\_ : \_\_\_ Mode>>IAS\_Cutoff= \_\_\_ Arinc= \_\_\_ DASH \_\_\_\_\_

Trim >> Alt: \_\_\_ : \_\_\_ IAS: \_\_\_ : \_\_\_ Baro: \_\_\_ : \_\_\_ OAT: \_\_\_ : \_\_\_ Hdg: \_\_\_ : \_\_\_

Fuel >> K = \_\_\_ : \_\_\_ S delay \_\_\_\_\_ lb/g

### 4.3 Status Line Descriptions

There are three status lines that indicate the various parameter settings. The first line contains information about the RS232 port communication settings.:

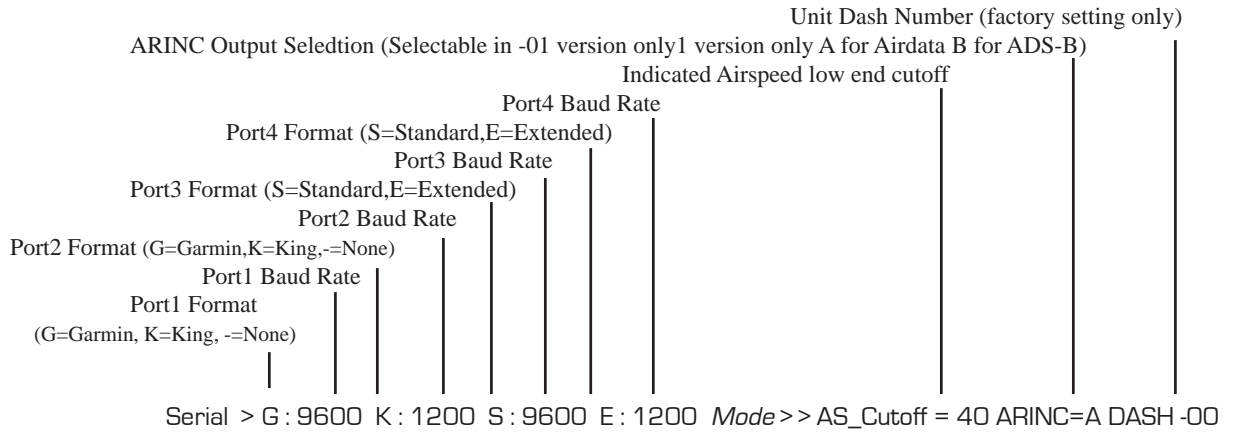

Figure 4-2  
RS-232 Status Lines Setting

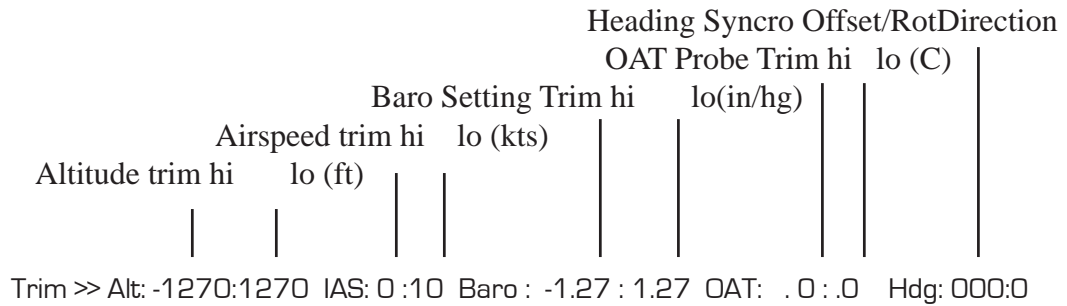

Figure 4-3  
SAC 7-35 Configuration Mode - Unit Trim Status

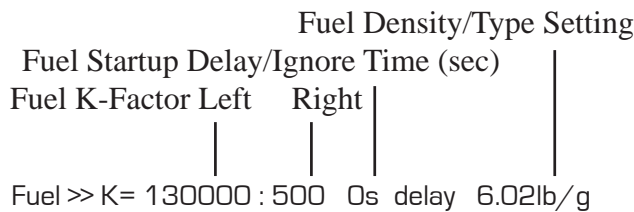

Figure 4-4  
SAC 7-35 Configuration Mode - Unit Fuel Status

## Parameter Descriptions

### 4.3.1 Serial Port Settings

Parameter	Description	Allowed Settings
1. Port 1 Format	Set Port 1 (RS232A) Data Format	1. Garmin-Z 2. King-D 3. Garmin-G 5. Disable
2. Port 1 Baud	Set Port 1 (RS232A) Baud Rate	1. 1200 bps 2. 9600 bps 3. 19200 bps 4. 38400 bps
3. Port 2 Format	Set Port 2 (RS232B) Data Format	1. Garmin-Z 2. King-D 3. Garmin-G 4. ADS-B 5. Disable
4. Port 2 Baud	Set Port 2 (RS232B) Baud Rate	1. 1200 bps 2. 9600 bps 3. 19200 bps 4. 38400 bps
5. Port 3 Format	Set Port 3 (RS232C) Data Format	1. Standard 2. Extended 3. No Output
6. Port 3 Baud	Set Port 3 (RS232C) Baud Rate	1. 1200 bps 2. 9600 bps 3. 19200 bps 4. 38400 bps
7. Port 4 Format	Set Port 4 (RS232D) Data Format	1. Standard 2. Extended 3. No Output
8. Port 4 Baud	Set Port 4 (RS232D) Baud Rate	1. 1200 bps 2. 9600 bps 3. 19200 bps 4. 38400 bps

### 4.3.2 Airspeed Trim

Parameter	Description	Allowed Settings
9. Airspeed Trim	Adjust for high speeds. Moves speeds +/-12.7 knots in 0.1 kt increments. Use a negative sign for negative trim.	+/- 12.7 knots
	Adjust for low speeds. Moves low speeds +/-12.7 knots in 0.1 kt increments. Use a negative sign for negative trim.	+/- 12.7 knots

## Parameter Descriptions Con't

### 4.3.3 Syncro Input Settings

Parameter	Description	Allowed Settings
h. Syncro Rotation	Direction of rotation	0. Positive Rotation 1. Negative Rotation
i. Synchro Index	Adjustment of synchro input index	0-359 degrees in 1 degree steps

### 4.3.4 Altitude Trim

The altitude trim adjusts all of the SAC 7-35 encoder altitude output including: the Gillham Grey code and serial encoder..

There are two trim values, high trim and low trim. The low trim value is applied for sea level altitudes. The high trim value is applied at the units certified service ceiling 35,000ft. For other altitudes the two trim values are interpolated.

Parameter	Description	Allowed Settings
a. Altitude Trim	Adjust for high altitudes. Moves high altitudes +/-635 feet in 5' increments. Use a negative sign for negative trim.	+/- 635 (feet)
	Adjust for low altitudes. Moves low altitudes +/-635 feet in 5' increments. Use a negative sign for negative trim.	+/- 635 (feet)

### 4.3.5 Baro Setting Trim

Parameter	Description	Allowed Settings
b. Baro Trim	Adjust for high and low Baro settings Enter high and then low trim offsets	+/- 127 0.01 inHg

### 4.3.6 Airspeed Cutoff

Parameter	Description	Allowed Settings
c. Airspeed Cutoff	Select the airspeed cutoff value. Below the cutoff value the airspeed is output as zero to minimize wind gust airspeed reports on the ground. Enter the desired value in knots: Even values 40 and 0-28 are supported.	0-40

## Parameter Descriptions Con't

### 4.3.7 Fuel Flow Configuration and K-factor

Parameter	Description	Allowed Settings
d. Fuel Start-up delay	Delay Fuel Flow Calculation	(0-12 for 0-60 second delay)
e. Fuel Input	Engine count	0 ,1,2
f.	Fuel Density	0 = 100LL 1 = Jet B 2 = Jet 1A 3 = JetA or enter #
k.	Fuel Transducer K-Factors (L&R)	500-130000

### 4.3.8 List Inputs

Parameter	Description	Allowed Settings
l. List Inputs	<p>This configuration menu selection lists the current Altitude, Airspeed, Outside Air Temperature and Baro Setting. The list is in the form:</p> <p>Trimmed inputs&gt;&gt;Alt=1234 IAS=321 Baro=29.92 OAT=15.12</p> <p>The alt is in feet, IAS knots, Baro InHg and OAT in Deg C</p>	N/A

### 4.3.9 ARINC Mode

**Note: The ARINC output select is available only in-01 units. In -01 units the ARINC 429 output can be disabled. The output can also be configured for Airdata only, ADS-B only or both**

Parameter	Description	Allowed Settings
m. Mode Select	<p>Select the ARINC output mode</p> <p>0. ARINC 429 Output Disable 1. ARINC 429 Output Airdata Only 2. ARINC 429 Output ADS-B only 3. ARINC 429 Output ADS-B and Airdata</p>	0-3



#### 4.3.10 OAT Probe Trim

The OAT probe trim should always be set to 0 for SAC 7-35 installations with the Sandia Aerospace OAT Probe (305561-01).

Parameter	Description	Allowed Settings
o. OAT Probe	Outside Air Temperature Trim Enter high and then low trim offsets	+/-127 0.05° C

#### 4.4 Continued Airworthiness

The encoder portion of the SAC 7-35 requires calibration every 24 months per FAR 91.411. All other maintenance is on condition only.

.