

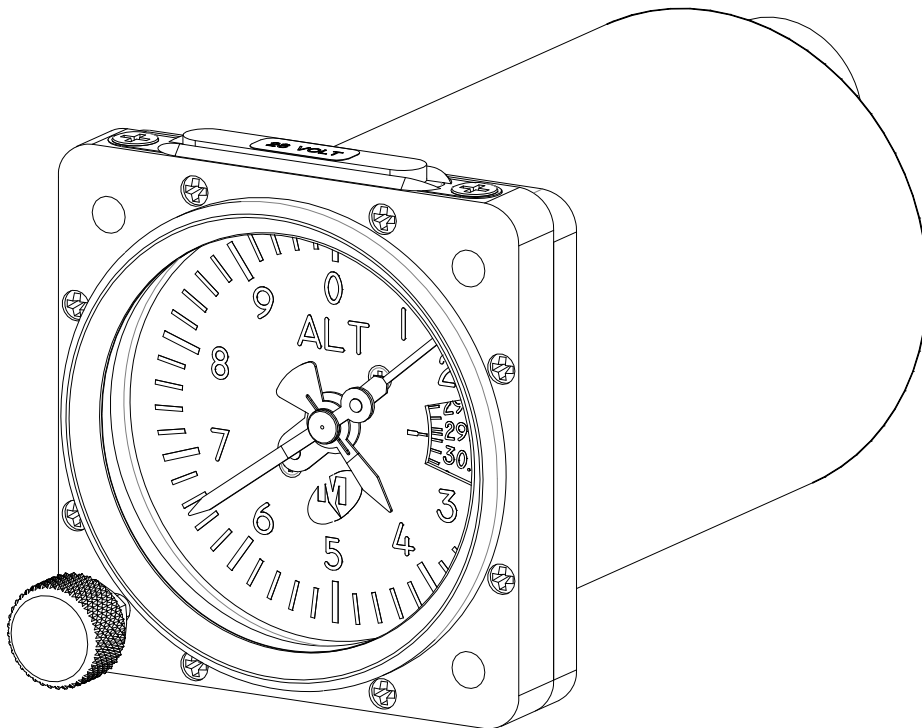

INSTALLATION MANUAL AND OPERATING INSTRUCTIONS

MD15-() Series Altimeter



REV. D July 14, 2011

MANUAL NUMBER 9017061

Mid-Continent Instruments and Avionics
9400 E. 34th Street N., Wichita, KS 67226 USA
phone 316-630-0101 • fax 316-630-0723 • web www.mcico.com

FOREWORD

This manual provides information intended for use by persons who, in accordance with current regulatory requirements, are qualified to install this equipment. If further information is required, please contact:

Mid-Continent Instruments and Avionics
Attn: Customer Service Dept.
9400 E. 34th Street N.
Wichita, KS 67226 USA
Phone 316-630-0101 Fax 316-630-0723

We welcome your comments concerning this manual. Although every effort has been made to keep it free of errors, some may occur. When reporting a specific problem, please describe it briefly and include the manual part number, the paragraph/figure/table number, and the page number. Send your comments to:

Mid-Continent Instruments and Avionics
Attn: Technical Publications
9400 E. 34th Street N.
Wichita, KS 67226 USA
Phone 316-630-0101, Fax 316-630-0723
info1@mcico.com
www.mcico.com

© Copyright 2010
Mid-Continent Instruments and Avionics

REVISION DETAIL

Rev.	Date	Approved	Detail
A	06/25/10	CJM/BAW	Initial release
B	08/12/10	BAW/CJM	Updated Table 1.2 with Humidity and Magnetic Effect info. Added detail to Section 4 Conformance table.
C	10/15/10	MKN/CJM	Changed 0.890/0.885 from Ø2.625BC hole to knob hole cutout in Figure 3.2.
D	07/14/11	MKN/CJM	Added DO-160 Environmental Qualifications in Sections 1.2.2 and 4.2.

TABLE OF CONTENTS

1. GENERAL DESCRIPTION

- 1.1 INTRODUCTION
- 1.2 TECHNICAL SPECIFICATIONS
 - 1.2.1 PHYSICAL ATTRIBUTES
 - 1.2.2 QUALIFICATIONS

SECTION 2 INSTALLATION PROCEDURE

- 2.1 GENERAL INFORMATION
- 2.2 UNPACKING AND INSPECTING
- 2.3 INSTALLATION
- 2.4 LIMITATIONS

SECTION 3 OPERATION

- 3.1 MINIMUM PERFORMANCE REQUIREMENTS
 - 3.1.1 SCALE ERROR
 - 3.1.2 HYSTERESIS
 - 3.1.3 AFTER EFFECT
 - 3.1.4 FRICTION
 - 3.1.5 CASE LEAK
 - 3.1.6 POSITION ERROR
 - 3.1.7 BAROMETRIC SCALE ERROR

SECTION 4 CONFORMANCE

- 4.1 CONTINUED AIRWORTHINESS STATEMENT
- 4.2 ENVIRONMENTAL QUALIFICATION STATEMENT

NUMBER LIST OF TABLES AND FIGURES

- 1.1 PHYSICAL ATTRIBUTES TABLE
- 1.2 QUALIFICATION TABLE
- 1.3 CONFIGURATION DATA
- 3.1 MD15 OUTLINE DRAWING
- 3.2 PANEL CUTOUT DIMENSIONS
- 3.3 MD15 REAR VIEW

SECTION 1 GENERAL DESCRIPTION

1.1 INTRODUCTION

The model MD15-() series two-inch Altimeter is a pressure actuated, sensitive altimeter built to meet or exceed SAE AS392C standards as per FAA TSO-C10b.

Features include a three-pointer indication (100 feet, 1000 feet, and 10,000 feet) and an inset dial displaying the manual knob adjustment for barometric pressure correction. Internally, a compensation mechanism maintains accuracy throughout the rated temperature range.

1.2 TECHNICAL SPECIFICATIONS

1.2.1 PHYSICAL ATTRIBUTES

Table 1.1

Characteristics:	
Weight:	0.8 pounds
Dimensions:	See outline drawing; Figure 3.1
Colors:	Dial background is black #37038 per FED-STD-595 Markings are white #37875 per FED-STD-595 Pointers are white with black hub and counterweight Case and bezel are black
Cover Glass:	HEA (anti-reflective) coated per MIL-C-14806
Connection:	9/16-18 UNJF-3B per MS33649-06
Mounting:	Rear mount, see panel cutout; Figure 3.2
Lighting:	Field replaceable light tray available for 5, 14, & 28VDC input with incandescent bulbs or white LEDs

1.2.2 QUALIFICATIONS

Table 1.2

Specifications:	
Qualification:	FAA TSO-C10b
Environmental Qualification:	RTCA DO-160F Env. Cat. (C1)CXXXXWXSFSXXXXXXXXXXXX
Altitude, Valid	-1,000 ft to (rated range); see Section 1.3
Altitude, Survivable	-1,000 ft to +50,000 ft
Operating Temperature:	-30°C to +50°C (-22°F to +122°F)
Storage Temperature:	-65°C to +70°C (-85°F to +158°F)
Humidity:	95% @ +70°C and 100% @ +38°C
Magnetic Effect:	no effect at 0.0m from unit; DO-160F, Section 15, Category Y

1.3 CONFIGURATION DATA

Table 1.3

Part Number	Range (ft)	Barometer	Knob
MD15-211	20,000	Millibars	Right
MD15-212	20,000	Millibars	Left
MD15-221	20,000	In Hg	Right
MD15-222	20,000	In Hg	Left
MD15-311	35,000	Millibars	Right
MD15-312	35,000	Millibars	Left
MD15-321	35,000	In Hg	Right
MD15-322	35,000	In Hg	Left

** other versions or options may be available on request **

SECTION 2 INSTALLATION PROCEDURE

2.1 GENERAL INFORMATION

This section contains mounting dimensions and other information pertaining to the installation of the MD15 Altimeter.

2.2 UNPACKING AND INSPECTING EQUIPMENT

When unpacking this equipment, make a visual inspection for evidence of any damage that may have incurred during shipment. The following parts should be included:

- a. Altimeter – MCI P/N MD15-()
- b. Installation Manual – MCI P/N 9017061

Optional equipment available:

- a. Light tray (LED) – MCI P/N MD31, -4, -6 (28, 14, 5V)
- b. Light tray (incandescent) – MCI P/N 6015358-2 (28V)
MCI P/N 6015010-2 (14V)
MCI P/N 6018634-2 (5V)
- c. Tinnerman nuts (3) – MCI P/N 6013031

Equipment not provided:

- a. Mounting Hardware – three (3) #6-32 screws
#6 lock washers (optional)
- b. Air fitting – per aircraft mfg. requirements;
9/16-18 x 1/8-inch tube fitting available
(MCI P/N NY-400-1-6ST)

2.3 INSTALLATION

Install the MD15 Altimeter within the aircraft in accordance with the aircraft manufacturer's instructions and the following steps:

- A. Ensure the available instrument panel cutout meets the requirements of the indicator. See Fig 3.2
- B. Secure the indicator to the instrument panel using the screw sizes called out in the Section 2.2. Length of screws will be determined by aircraft instrument panel thickness. The aircraft manufacturer or the installation facility is responsible for supplying appropriate hardware.
- C. Connect static line tube to the pressure port on the back of the altimeter.

CAUTION: INSTALL FITTING IN PORT WITH NO MORE THAN 100 IN-LBS OF TORQUE. IF TORQUE IS NOT SUFFICIENT TO MAINTAIN A SEAL THREAD SEALANT MUST BE USED.

- D. For units with light tray, connect wires to the appropriate voltage as marked on the light tray.

2.4 LIMITATIONS

The conditions and tests for TSO approval of this article are minimum performance standards. Those installing this article, on or in a specific type or class of aircraft, must determine that the aircraft installation conditions are within the TSO standards. TSO articles must have separate approval for installation in an aircraft. The article may be installed only according to 14 CFR part 43 or the applicable airworthiness requirements.

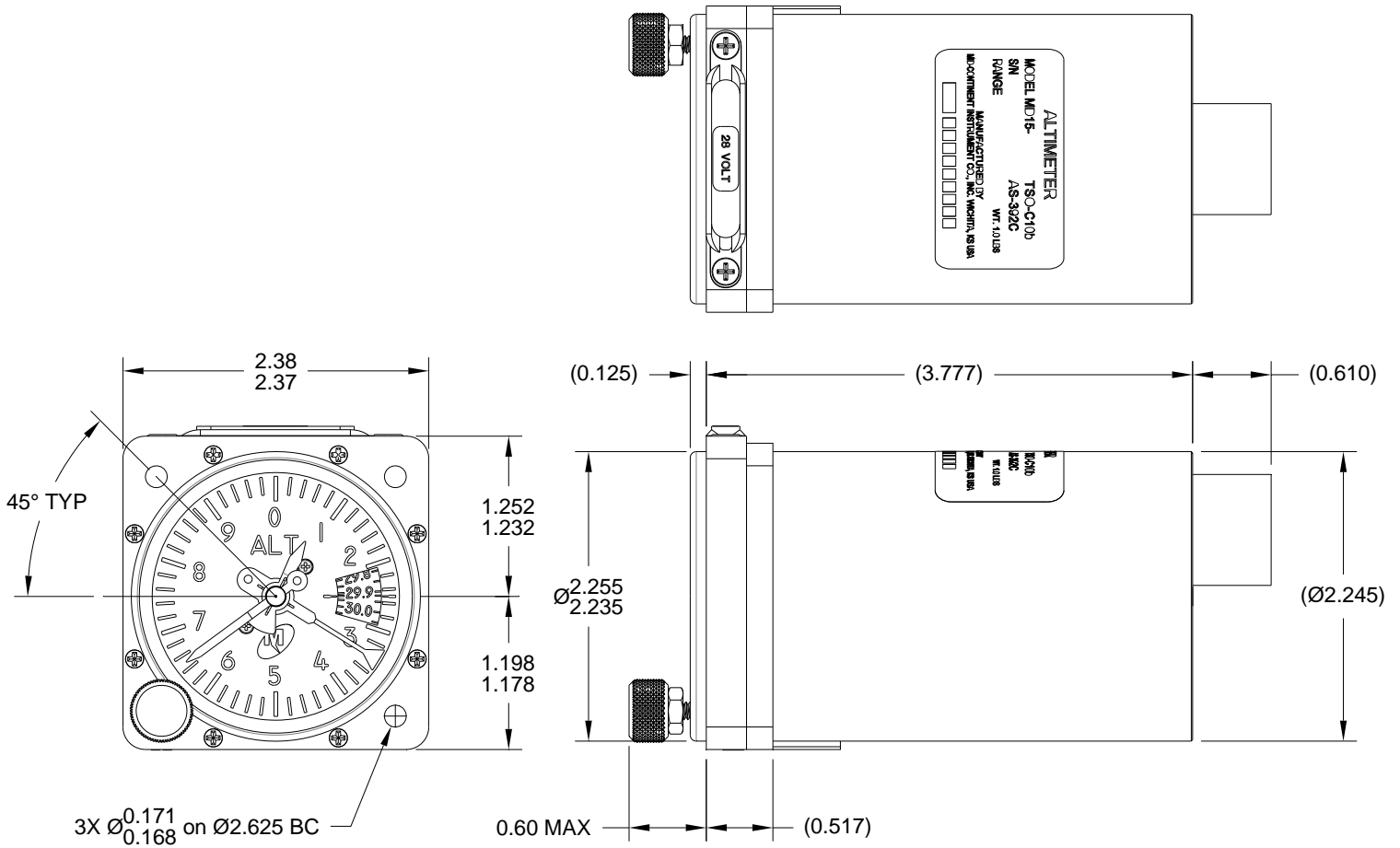

FIGURE 3.1
MD15 OUTLINE DRAWING

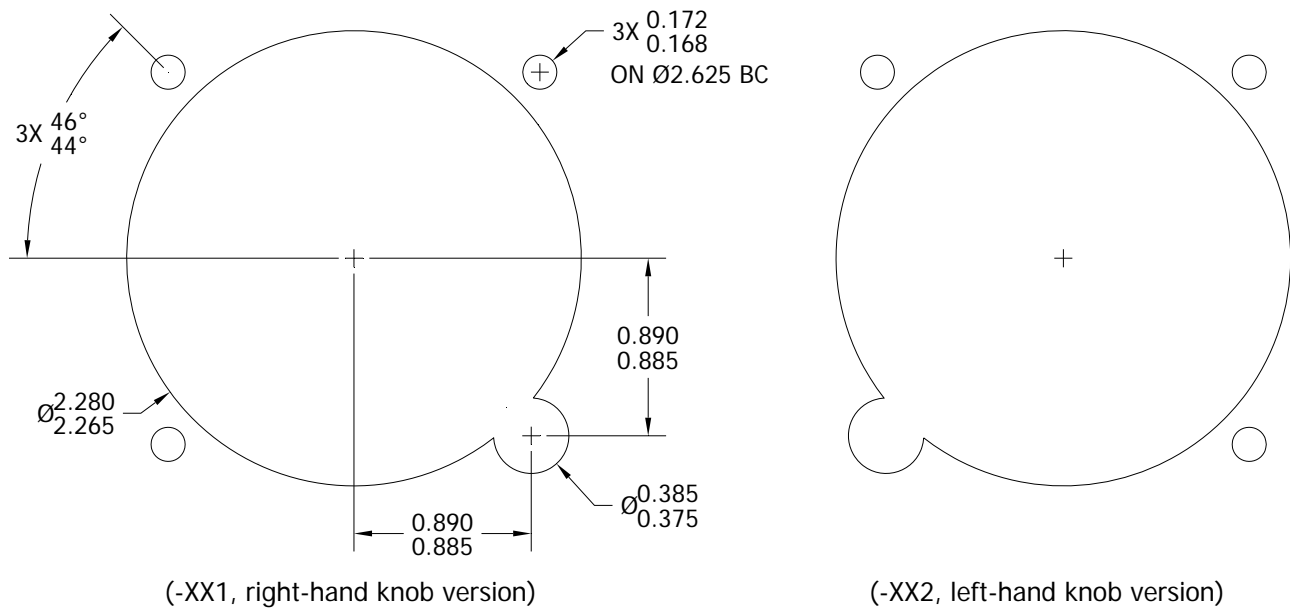

FIGURE 3.2
PANEL CUTOUT DIMENSIONS

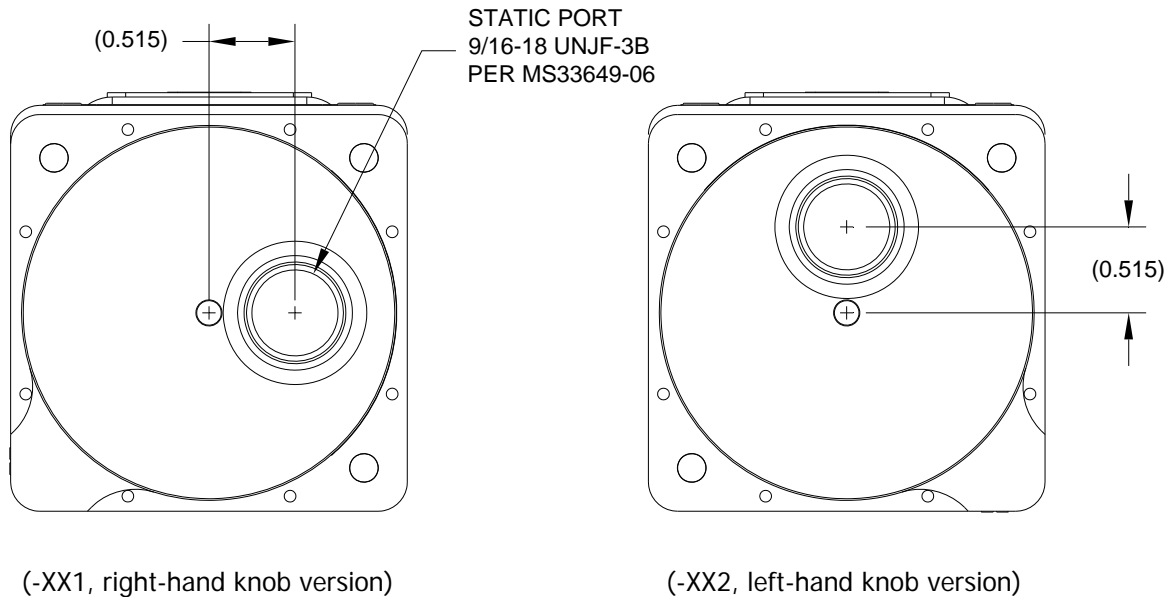

FIGURE 3.3
MD15 REAR VIEW

SECTION 3 OPERATION

3.1 MINIMUM PERFORMANCE REQUIREMENTS

The MD15 Altimeter shall meet these minimum performance requirements under standard test conditions.

3.1.1 SCALE ERROR

With the barometric scale pressure set at 29.92 inches of mercury (1013 millibars), the altimeter shall be subjected successively to equivalent pressures from -1,000 ft to the rated altitude of the instrument at the increments established by Table 3.1. The reduction in pressure shall not exceed 20,000 feet per minute to within 2,000 feet of the test point. The test point shall be approached at a rate compatible with the test equipment. The instrument shall remain at each test point for at least one minute but not more than ten minutes before a reading is taken. The error at all test points shall not exceed the tolerances stated in Table 3.1.

3.1.2 HYSTERESIS

The hysteresis test requirement shall be verified within 15 minutes of reaching the upper limit of the Scale Error test as described in Section 3.1.1. Pressure shall be increased at a rate simulating a descent in altitude between 5,000 and 20,000 feet per minute until within 3,000 feet of half (50%) of the instrument's rated maximum operating altitude (per 14 CFR Part 43, Appendix E). Then the test point shall be approached at approximately 3,000 feet per minute. Within 10 seconds after the pressure has been stabilized at the test point, the instrument indication shall be within 100 ft of the original scale error reading. The altimeter shall be kept at this pressure for at least 5 minutes, but not more than 15 minutes, before the reading is taken. After the reading has been taken, the pressure shall be further increased at the above rate until the pressure reaches a corresponding altitude of 40% of the instrument's rated maximum operating altitude. The instrument shall remain at this pressure for at least one minute, but not more than 10 minutes, before the test reading is taken. After the reading has been taken, the pressure shall be further increased at the above rate until atmospheric pressure is reached. The reading of the instrument at either of the two test points shall not differ from the instrument reading taken at an equivalent altitude recorded during the Scale Error test by more than 75 feet.

3.1.3 AFTER EFFECT

Not more than five minutes after the completion of the hysteresis test, the pointers shall have returned to their original reading, corrected for any change in atmospheric pressure, to within 30 feet.

3.1.4 FRICTION

The altimeter shall be subjected to a steady rate of decreasing pressure equivalent to about 750 feet per minute. The change in reading of the pointer before and after the application of vibration shall be recorded at the values indicated and within the tolerance as listed in Table 3.1.

Note: Where TSO prescribe altitude values for Friction test points do not match test points in the Scale Error test, test points before and after the target value have been selected for this test. (for example: where 5000 ft is called for, test points are taken at 4000 and 6000 instead, to match the Scale Error test) This method exceeds the TSO requirement.

3.1.5 CASE LEAK

With an equivalent pressure of 18,000 feet applied, the resultant leakage shall not cause the indicator to deviate more than 100 feet within one minute.

3.1.6 POSITION ERROR

With atmospheric pressure applied to the instrument, the difference between pointer indication when the instrument is in normal operating position and when it is in any other position shall not exceed 20 feet.

3.1.7 BAROMETRIC SCALE ERROR

With ambient pressure constant, the barometric pressure scale shall be adjusted to each of the values as listed in Table 3.2 and cause the instrument to indicate the corresponding altitude within a tolerance of ± 25 feet.

**Table 3.1
Scale Error and Friction Error**

Altitude (feet)	Equivalent Pressure (inches of mercury)	Scale Error Tolerance \pm (feet)	Friction Error Tolerance \pm (feet)
-1,000	31.018	20	---
0	29.921	20	---
500	29.385	20	---
1,000	28.856	20	70
1,500	28.335	25	---
2,000	27.821	30	70
3,000	26.817	30	70
4,000	25.842	35	70
6,000	23.978	40	70
8,000	22.225	60	---
10,000	20.577	80	80
12,000	19.029	90	---
14,000	17.577	100	80
16,000	16.216	110	90
18,000	14.942	120	---
20,000	13.750	130	100
22,000	12.636	140	---
25,000	11.104	155	120
30,000	8.885	180	140
35,000	7.041	205	160

--- = no friction error reading required at this test point

**Table 3.2
Barometric Scale Error**

Barometric Scale Reading		Indication (feet)
MB	IN HG	
951.6	28.10	-1,727
965.1	28.50	-1,340
982.0	29.00	-863
999.0	29.50	-392
1013.2	29.92	0
1032.8	30.50	+531
1046.4	30.90	+893
1049.4	30.99	+974

SECTION 4 CONFORMANCE

4.1 CONTINUED AIRWORTHINESS STATEMENT

Federal regulations require that within the preceding 2 calendar years an active altimeter instrument be tested and found to comply with FAR Part 43 Appendix E. If the unit fails to perform to specifications within this period, it must be removed and serviced by a qualified service facility.

4.2 ENVIRONMENTAL QUALIFICATION STATEMENT

NOMENCLATURE: Altimeter
MODEL NUMBER: MD15-() **TSO NUMBER:** C10b
MANUFACTURERS SPECIFICATIONS: Minimum Performance Specifications:
Test Specification (TS) 350, Test Data Sheet (TDS) 350
QUALIFICATION STANDARD: FAA TSO C10b and SAE AS 392C & RTCA DO-160F

FAA TSO C10b and SAE AS 392C		
CONDITIONS	TSO SECTION	DESCRIPTION
Temperature Ground Survival Low Operating Low Ground Survival High Operating High	3.3.1	-65C -30C +70C +50C
Humidity	3.3.2	95% at 70°C and 100% at 38°C
Vibration	3.3.3	5-50 Hz @ 1.5g, 50-500 Hz @ 0.5g four complete cycles, no observed resonance
Altitude, Valid	3.3.4	-1,000 ft to (rated range)
Altitude, Survivable	3.3.4	-1,000 ft to +50,000 ft
Magnetic Effect	3.3.5	RTCA, DO-160F, Category Y zero magnetic effect at 0.0m from unit

RTCA DO-160F		
CONDITIONS	SECTION	DESCRIPTION OF TEST
Temperature and Altitude	4	Category C1
Short Term Operating Low	4.5.1	-40C
Short Term Operating High	4.5.5	+70C
Temperature Variation	5	Category C
Waterproofness	10	Category W
Sand and Dust	12	Category S
Fungus	13	Category F
Salt Spray	14	Category S

Configuration

Dash #	Range (ft)	Barometer	Knob	Assembly
-211	20,000	Millibars	Right	9016871-1
-212	20,000	Millibars	Left	9016871-2
-221	20,000	In Hg	Right	9016871-3
-222	20,000	In Hg	Left	9016871-4
-311	35,000	Millibars	Right	9016871-5
-312	35,000	Millibars	Left	9016871-6
-321	35,000	In Hg	Right	9016871-7
-322	35,000	In Hg	Left	9016871-8

Revision

ECO	Rev.	Description	Date	Approved
	A	Production release.	04/13/10	CJM/JDS
5460	B	Added Warranty Decal location. Added 9017169 label.	09/02/10	MKN/CJM

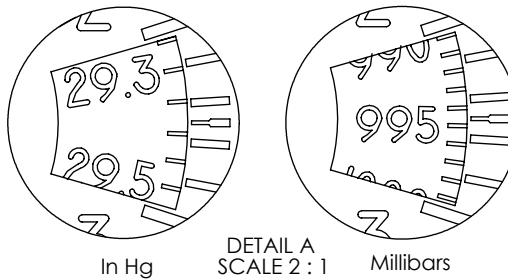
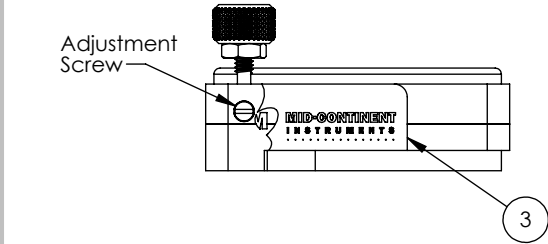
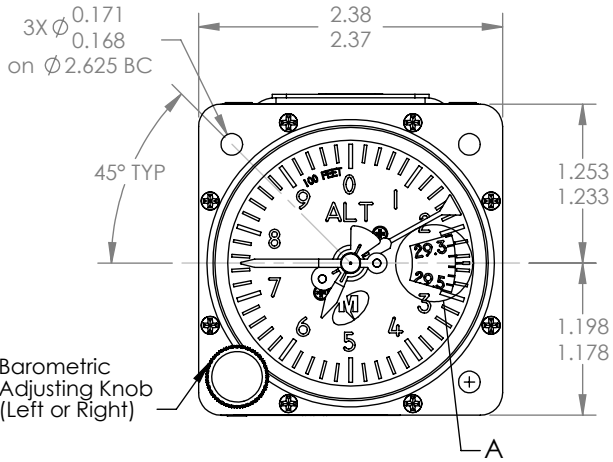
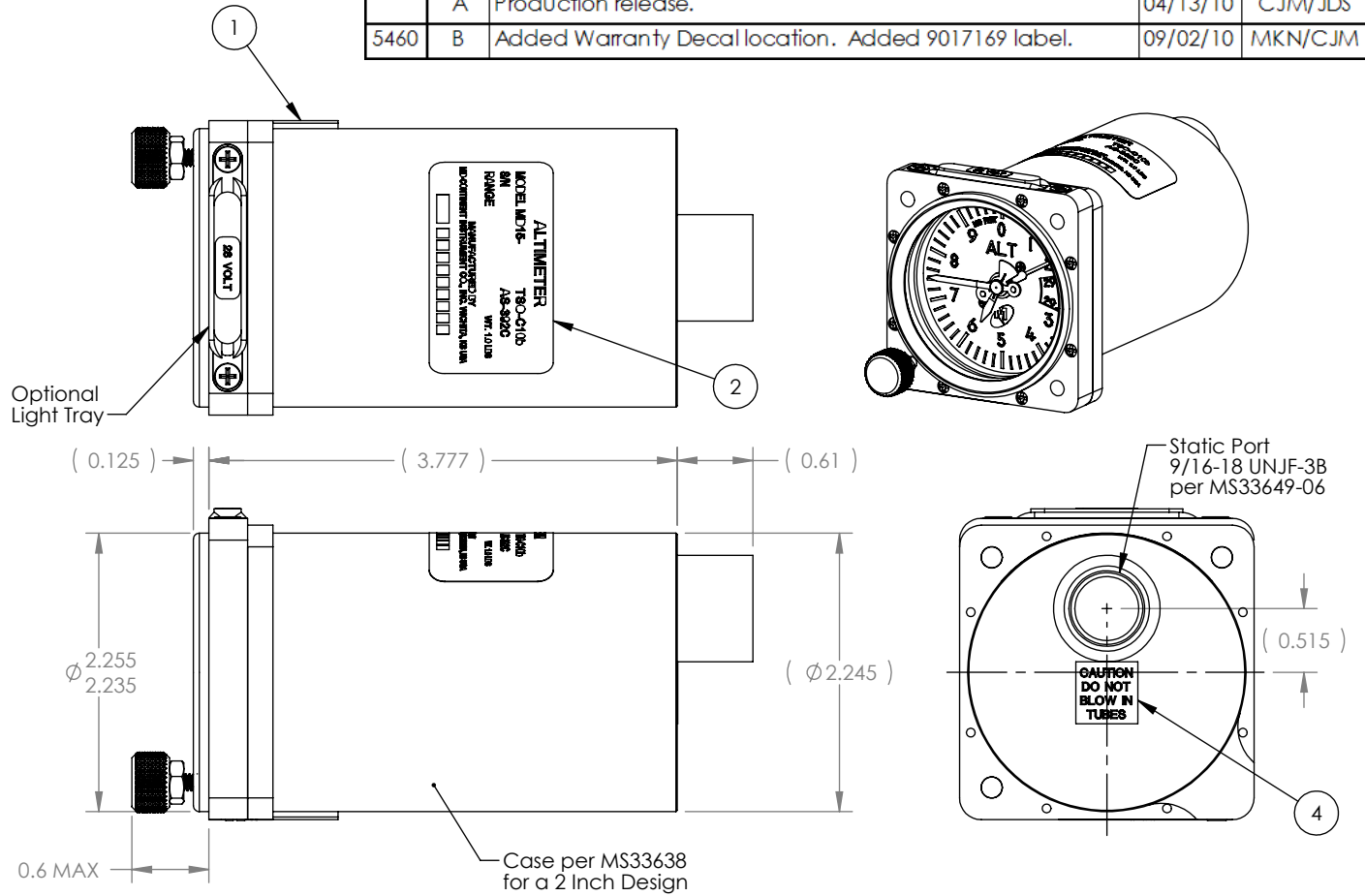

Item	Qty	Part Number	Description
1	1	See Config	Assembly, Altimeter
2	1	9017060	Nameplate
3	1	6018956	Decal, Warranty
4	1	9017169	Label, Caution

Certification:	FAA TSO-C10b
Range:	-1000 to 20,000 or 35,000 feet
Scale:	Millibars (mb) or Inches of Mercury (InHg)
Lighting:	Field Replaceable LED or Incandescent Light Tray available for 5, 14, or 28VDC input
Colors:	Dials: Black #37038 per FED-STD-595 Pointers and Text: White #37875 per FED-STD-595 Case, Bezel, & Knob: Black
Weight:	0.8lb.

UNLESS OTHERWISE SPECIFIED, ALL DIMENSIONS ARE IN INCHES.
TOLERANCE:
FRACTIONAL=±1/64
.XX=±0.015
.XXX=±0.005
.XXXX=±0.002
ANGULAR=±0.5°
CONCENTRICITY: 0.005 TIR
BREAK ALL SHARP EDGES
THREADS PER MIL-S-7742

DRAWN:
C. Mies
4/13/2010
APPROVED:
JDS
4/13/2010

This document discloses proprietary information of Mid-Continent Instrument Co. It may be reproduced or disclosed only with written permission of Mid-Continent Instrument Co. and is not to be used in any way detrimental to the interests of Mid-Continent Instrument Co.

MidContinent
INSTRUMENTS+AVIONICS

TITLE: Indicator, Altimeter, 2-inch	PART NUMBER: MD15
SCALE: 2:3	DO NOT SCALE THIS DRAWING
SHEET: 1 of 1	