

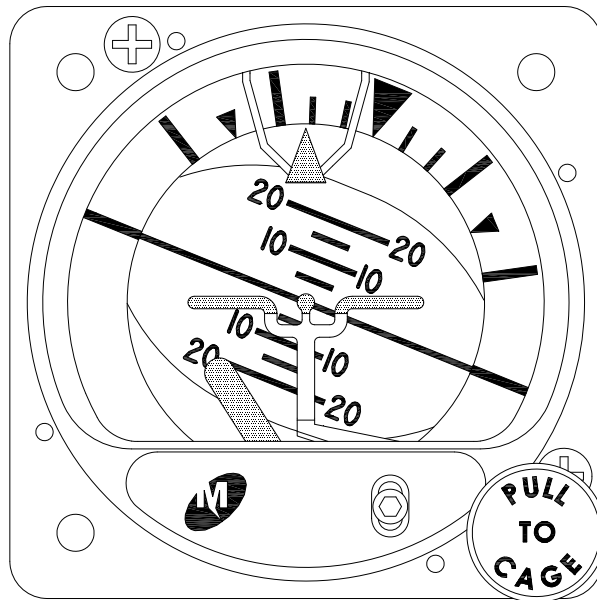

## INSTALLATION MANUAL AND OPERATING INSTRUCTIONS

### 4200 Series Electric Attitude Indicator



Mid-Continent Instruments and Avionics  
9400 E 34<sup>th</sup> Street N, Wichita, KS 67226 USA  
Phone 316-630-0101 • Fax 316-630-0723

Manual Number 9016182  
Rev D, September 1, 2009

**FOREWORD**

This manual provides information intended for use by persons who, in accordance with current regulatory requirements, are qualified to install this equipment. If further information is required, please contact:

Mid-Continent Instruments and Avionics  
Attn: Customer Service Dept.  
9400 E. 34<sup>th</sup> ST North  
Wichita, KS 67226 USA  
Phone 316-630-0101 Fax 316-630-0723

We welcome your comments concerning this manual. Although every effort has been made to keep it free of errors, some may occur. When reporting a specific problem, please describe it briefly and include the manual part number, the paragraph/figure/table number, and the page number. Send your comments to:

Mid-Continent Instruments and Avionics  
Attn: Technical Publications  
9400 E. 34<sup>th</sup> ST North  
Wichita, KS 67226 USA  
Phone 316-630-0101, Fax 316-630-0723  
[info1@mcico.com](mailto:info1@mcico.com)  
[www.mcico.com](http://www.mcico.com)

**Table of Contents**

		<b>Page</b>
<b>Section 1</b>	<b>General Description</b>	5
1.1	Purpose of Equipment	5
1.2	Physical Description	5
1.3	Functional Description	5
1.4	Gyro Warning Flag	5
1.5	Options and Configurations	5
1.6	Specifications	6
<b>Section 2</b>	<b>Installation</b>	9
2.1	General	9
2.2	Pre-Installation Inspection	9
2.3	Parts	9
2.3.1	Included Parts	9
2.3.2	Installer Supplied Parts	10
2.4	Equipment Location	10
2.5	Installation	10
2.6	Continued Airworthiness	11
<b>Section 3</b>	<b>Operation</b>	14
3.1	General	14
3.2	Starting Procedures	14
3.3	In-Flight Procedures	14
3.4	Dynamic Errors	14
<b>Figure No.</b>	<b>List of Illustrations</b>	
1.1	Display Configurations	7
1.2	Typical Indicator Display Detail	8
2.1	Outline Drawing	12
2.2	Panel Cutout Dimensions	13
<b>Table No.</b>	<b>List of Tables</b>	
1.1	Options Table	5
1.2	Physical Characteristics	6
1.3	Performance	6

## Revision Detail

<u>ECO</u>	<u>Rev.</u>	<u>Date</u>	<u>Detail</u>
	A	08/22/05	Initial Release.
4535	B	02/03/06	Table 1.3: Update power rating.
4956	C	12/13/07	Update DO-160 qualification in section 1.6 from ...[WW] to ...[WF]... and from ...[A3C3]... to [A3H33]. Remove paragraph pertaining to Special HIRF Considerations in section 2.5. Note: This change is incorporated only on units identified as Mod Status 2 as indicated on the unit nameplate.
5270	D	09/01/09	Remove Equipment Limitations Section 3.5

## Section 1: General Description

### 1.1 Purpose of Equipment

The Model 4200 Electric Attitude Indicator incorporates a moving display that simulates the earth's horizon and provides the pilot with a real time visual indication of the aircraft pitch and roll attitude relative to the indicator symbolic airplane.

The instrument can function as a primary or standby indicator with a special configuration available to match electronic flight displays. The lighting voltage is user selectable and the input voltage can range from 10 to 32 VDC. Panel tilt is an option specified at the time of the order.

### 1.2 Physical Description

The 4200 Electric Attitude Indicator incorporates pitch and roll displays that are mechanically linked to a spinning mass gyroscope. The horizon bar moves behind the symbolic airplane. Precession error is corrected by the 4200's erection system or by pulling the "PULL TO CAGE" knob. A warning flag pops into view to indicate that the gyro motor is not receiving sufficient power to operate.

### 1.3 Functional Description

Model 4200 Electric Attitude Indicators employ an efficient electrically driven internal vertical gyroscope assembly incorporating a special air erection mechanism. This mechanism simultaneously erects the pitch and roll axes of the gyroscope. Movement of the aircraft generates a reaction of the display that simulates the visual reference seen by the pilot when looking outside at the earth's true horizon line.

The Indicator requires 10 to 32 VDC input voltage. The lighting system features internal LEDs that operate on a user selectable 5V, 14V or 28V input from the aircraft lighting bus.

### 1.4 Gyro Warning Flag

A power warning circuit monitors the electrical current used to power the gyro motor. When a loss of input voltage occurs, the gyro warning flag comes into view.

### 1.5 Options and Configurations

Options Table	
Panel Tilt Calibration	0° to 20°, set to customer requirements.
Symbolic Airplane	Part Number Specific: Traditional or Delta
Mating Connector	9015514 (MS3116F8-4S)

Table 1.1

**1.6. Specifications**

<b>Physical Characteristics:</b>	
Qualification:	FAA-TSO-C4c
Environmental Qualification:	RTCA DO-160D Environmental Category C1BABXXXXXXXXZZAZZ[WF]M[A3H33]XXA
Weight:	1.6 lbs
Dimensions:	Length behind panel (not including mating connector) 5.94 inches long maximum. 2.39 inches high maximum. 2.39 inches wide maximum.
Mating Connector:	MS3116F8-4S or equivalent (MCI P/N 9015514)
Cover Glass	HEA (anti-reflective) coated.
Instrument Panel Mounting:	Rear mount.

**Table 1.2**

<b>Performance:</b>	
Reliability	2500 Hour Mean Time Between Failure (MTBF)
Initial Erection:	The "PULL TO CAGE" knob will erect the gyroscope to within 2.0° of case vertical in roll and pitch from any position at any time.
Final Erection:	The vertical gyroscope should be allowed to spin up for 3 minutes after rated power is applied and after initial erection. After 5 minutes the final erection accuracy of pitch and roll will be within 1° of vertical.
Erection Rate:	Gyroscope will erect to local vertical in pitch and roll at 2.5° per minute minimum.
Warning Flag:	A gyro warning circuit provides for continuous monitoring of gyro voltage. If loss of gyro motor voltage occurs, the red warning flag will appear.
Symbolic Airplane:	The adjustment range will be ± 4° minimum from the zero pitch position.
Power Rating:	
Starting:	Will not exceed 1.4A at 14 VDC. Will not exceed 0.6A at 28 VDC.
Running:	0.37-0.51 at 14 VDC. 0.18-0.25 at 28 VDC.

**Table 1.3**

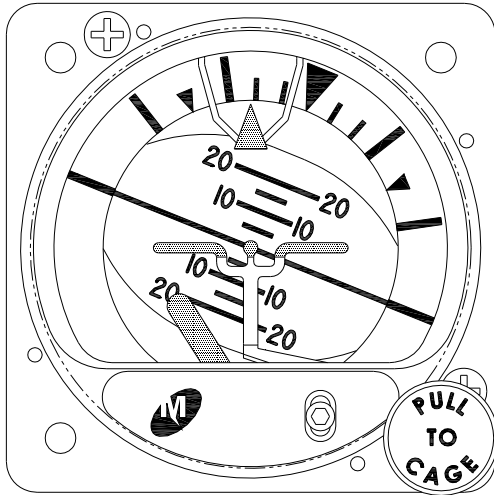

4200-10  
Traditional Symbolic Airplane  
Rotating Roll Dial  
Fixed Pointer

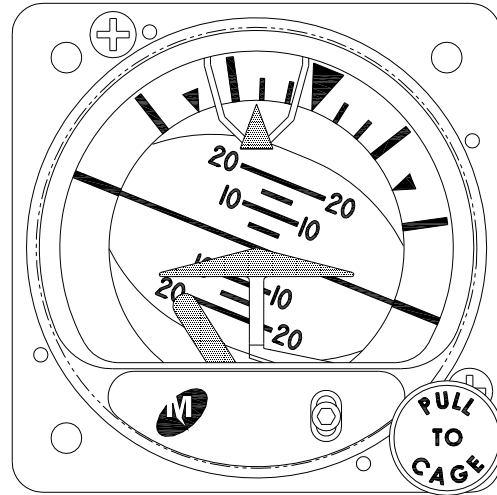

4200-11  
Delta Symbolic Airplane  
Rotating Roll Dial  
Fixed Pointer

**Figure 1.1**  
**Display Configurations**

- Roll Pointer:** Indicates aircraft roll displacement relative to a rotating roll dial.
- Power Indicator Flag:** If loss of input voltage should occur, power indicator flag will come into view.
- Display:** Lower area of display, when referenced to the symbolic airplane, indicates aircraft nose is below horizon or in a dive attitude. Upper area of display indicates aircraft nose is above horizon or in a climb attitude.
- Symbolic Airplane:** Indicates roll and pitch attitude relative to the horizon. The symbolic airplane can be moved (pitch only) using the symbolic airplane adjustment slide with locking screw.
- Horizon Line:** Indicates earth horizon relative to aircraft pitch and roll attitude.
- Caging Knob:  
(Manual Erection)** When pulled, manually erects the gyro vertical to the case orientation.
- Symbolic Airplane  
Adjustment:** Used to adjust the symbolic airplane to remove parallax errors.

**Typical Electric Attitude Indicator Display**

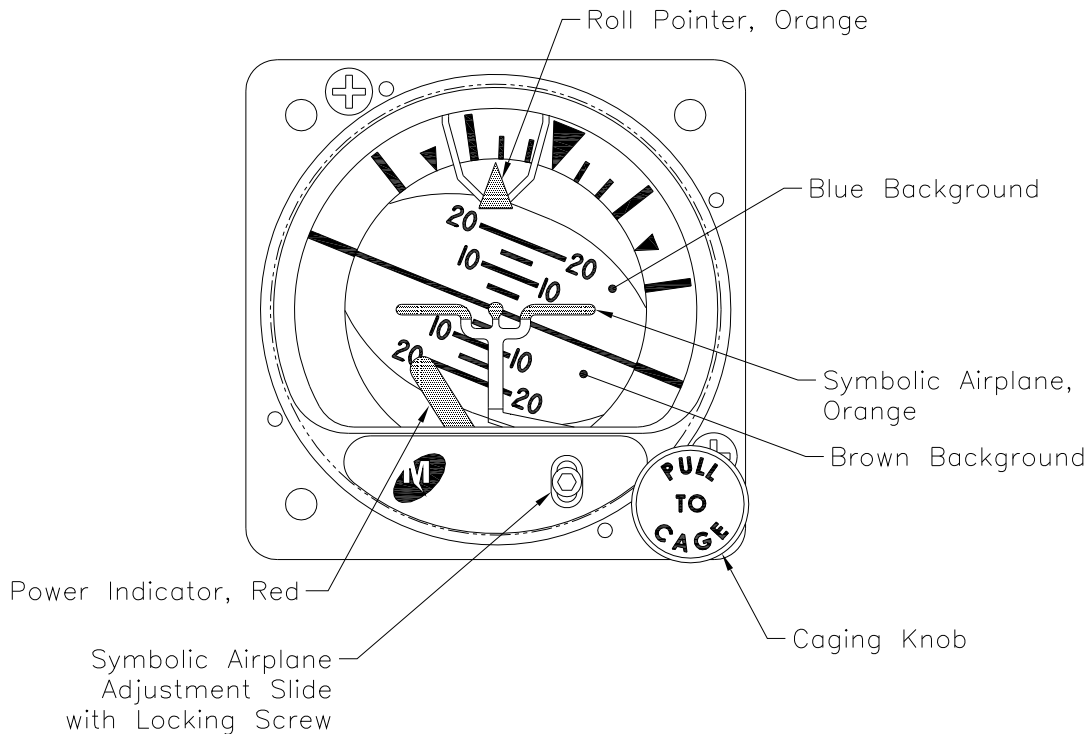

4200-10 configuration shown  
**Figure 1.2**



## Section 2: Installation

### 2.1 General

This section contains mounting, electrical connections and other information required for installation. After installation of cabling and before installation of the equipment, ensure that power is applied only to the pins specified in the interconnection diagram.

The conditions and tests required for the TSO approval of this article are minimum performance standards. It is the responsibility of those installing this article either on or within a specific type or class of aircraft to determine that the aircraft installation conditions are within the TSO standards. TSO articles must have a separate approval installation in an aircraft. The article may be installed only if performed under 14 CFR Part 43 or the applicable airworthiness requirements.

#### **CAUTION: GYROS ARE DELICATE INSTRUMENTS! THE FOLLOWING PRECAUTIONS MUST BE OBSERVED!!**

- A. A high gyroscope failure rate can be directly related to rough or improper handling. Gyros are delicate and cannot withstand the shock of being dropped, jarred, or struck by pieces of equipment. Do not place gyros on any hard surface. Pad with generous foam. Handle like eggs!
- B. To prevent damage to a gyro, the instrument should be transported to and from the aircraft in it's original shipping container. If this is impractical, the gyro should be hand-carried carefully in an upright position.
- C. A gyro should never be removed while it is spinning or running down. The instrument normally operates at high RPM and may take 10 minutes or longer to run down. If it is removed while running and tilted more than 20 degrees, the gyro can develop a gimbal lock. The gimbal will tumble and start to spin. If gimbal lock occurs while the rotor is turning, the gimbal may spin fast enough to damage the gimbal bearings, requiring overhaul.
- D. A malfunctioning gyro should be handled with the same care given a new instrument. Most malfunctioning instruments can be repaired and returned to service. Using proper handling procedures during removal prevents additional damage and helps ensure possible reuse.

### 2.2 Pre-installation Inspection

#### A. Unpacking

Carefully remove the attitude indicator from shipping container. The shipping container and packing materials should be retained for use should the attitude indicator require future shipment.

#### B. Inspect for Damage

Inspect the shipping container and attitude indicator for any signs of damage sustained in transit. If necessary, return attitude indicator to the factory using the original shipping container and packing materials. File any claim for damages with the carrier.

## 2.3 Parts

### 2.3.1 Included Parts

- A. Model 4200-( ) Electric Attitude Indicator
- B. Mating Connector, MS3116F8-4S or equivalent (P/N 9015514)
- C. Installation Manual (P/N 9016182)

### 2.3.2 Installer Supplied Parts

- A. Mounting Screw, 6-32UNC-2A. Three (3) required. (1" long screws are suggested for panel thickness between 0.05 and 0.19, but may not be optimum in some installations. The installer will need to determine what is correct for a particular installation.)

**CAUTION: Do not exceed 1.2" screw depth into bezel!**

## 2.4 Equipment Location

The attitude indicator should be located within the aircraft in accordance with the following considerations:

- A. The indicator is ideally located in the instrument panel directly in line with the pilot's normal line of sight. The "PULL TO CAGE" knob should be within easy reach. Installations that result in viewing angles in excess of 30 degrees may reduce display readability.
- B. Compare the space requirements of the indicator with the installation area being considered.
- C. The power cable should not run adjacent to heaters, engine exhausts, or other heat sources. Also, take care to route and tie the cable away from aircraft controls and cables.

## 2.5 Installation

**NOTE: Before installing unit, verify the option label on the unit matches the aircraft requirements for panel tilt.**

Install the Electric Attitude Indicator within the aircraft in accordance with the aircraft manufacturer's instructions and the following steps:

- A. Refer to Figure 2.1 for installation dimensions and electrical information. The recommended circuit breaker size is 2A. The minimum wire size is 22 AWG.
- B. Locate the lighting voltage switch on the rear of the unit. If required, switch the lighting voltage to the aircraft lighting bus voltage. Using a small pointed object, push the switches to select the lighting voltage per Fig 2.1.
- C. Ensure the available instrument panel cutout meets the requirements of the indicator. See Fig 2.2 for details.
- D. Attach aircraft electrical system cable to indicator connector and insert the indicator into the instrument panel cutout.

- E. Secure the indicator to the instrument panel using the screw sizes called out in the mounting instructions. Length of screws will be determined by aircraft instrument panel thickness. The aircraft manufacturer or the installation facility is responsible for supplying appropriate installation hardware.
- F. Apply the correct input power to the indicator.
- G. The Power Indicator Flag (red) will be out-of-view.
- H. Check to determine that the indicator internal lighting is working correctly. This indicator requires the main power to be on for the lighting to work. The indicator lighting will not work when just the lighting bus is turned on.

## **2.6 Continued Airworthiness**

No periodic scheduled maintenance or calibration is necessary for continued airworthiness of the 4200 series Electric Attitude Indicator. If the unit fails to perform to specifications, it must be removed and serviced by a qualified service facility.

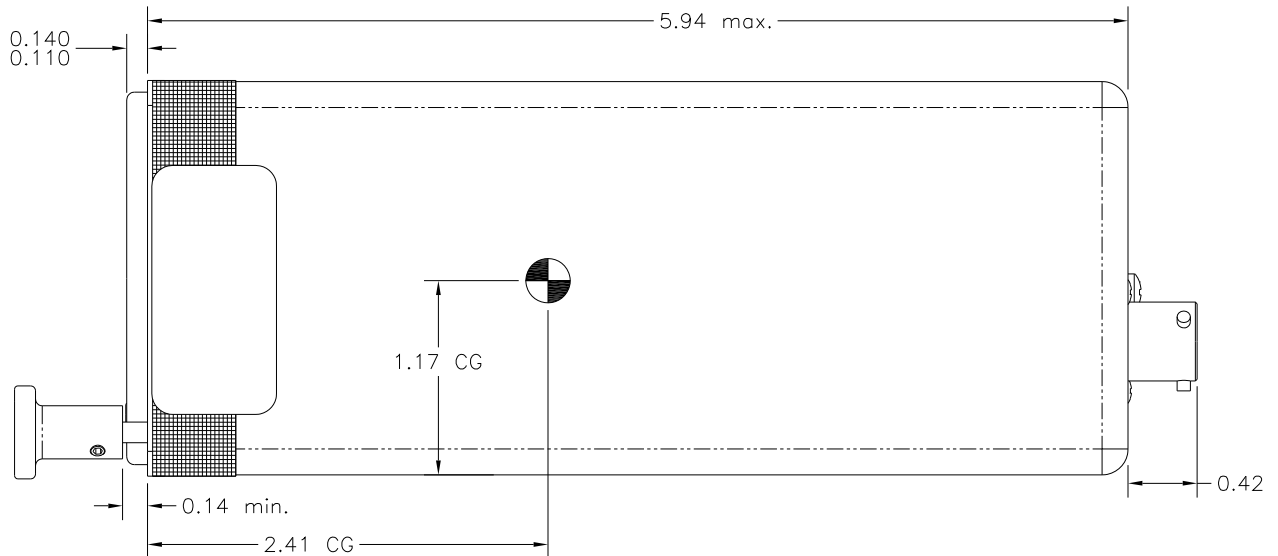
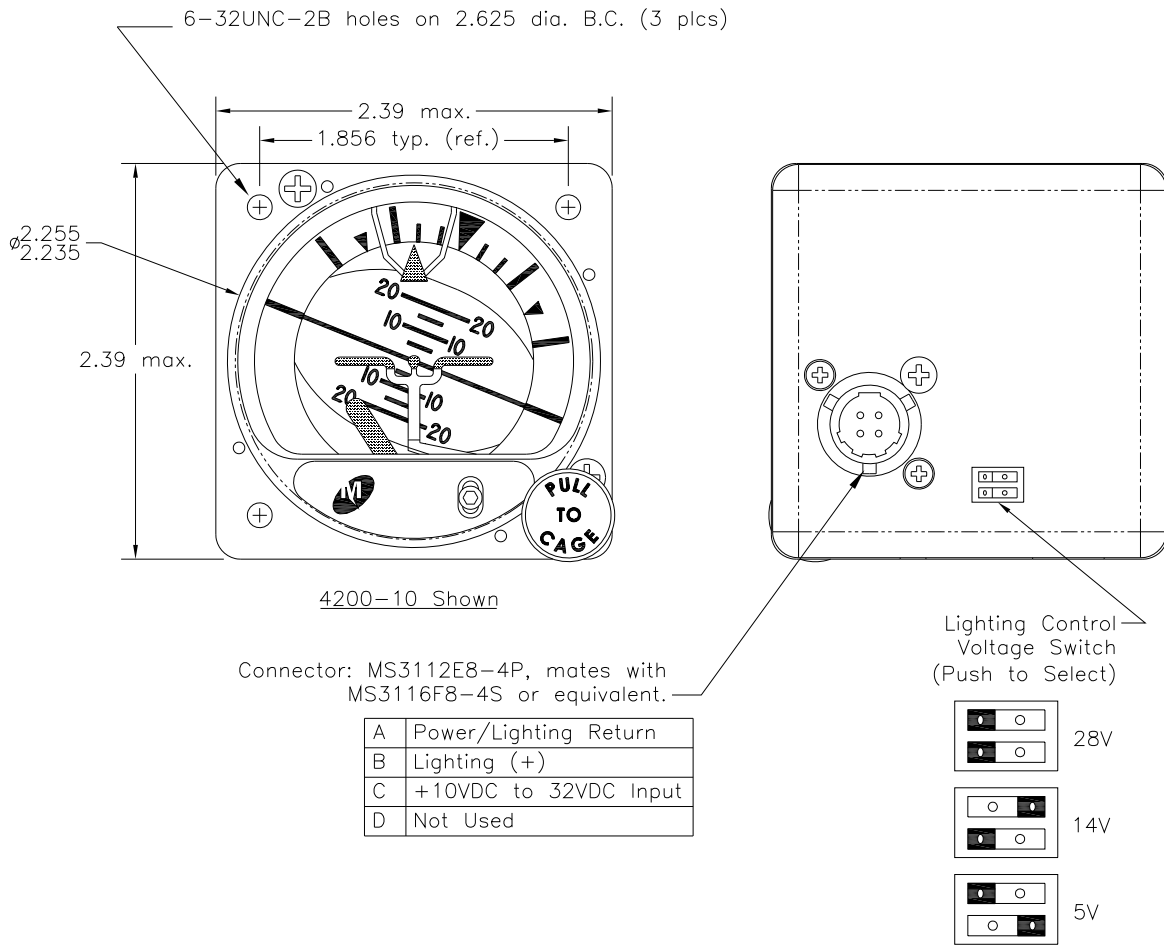

**Figure 2.1 Outline Drawing**

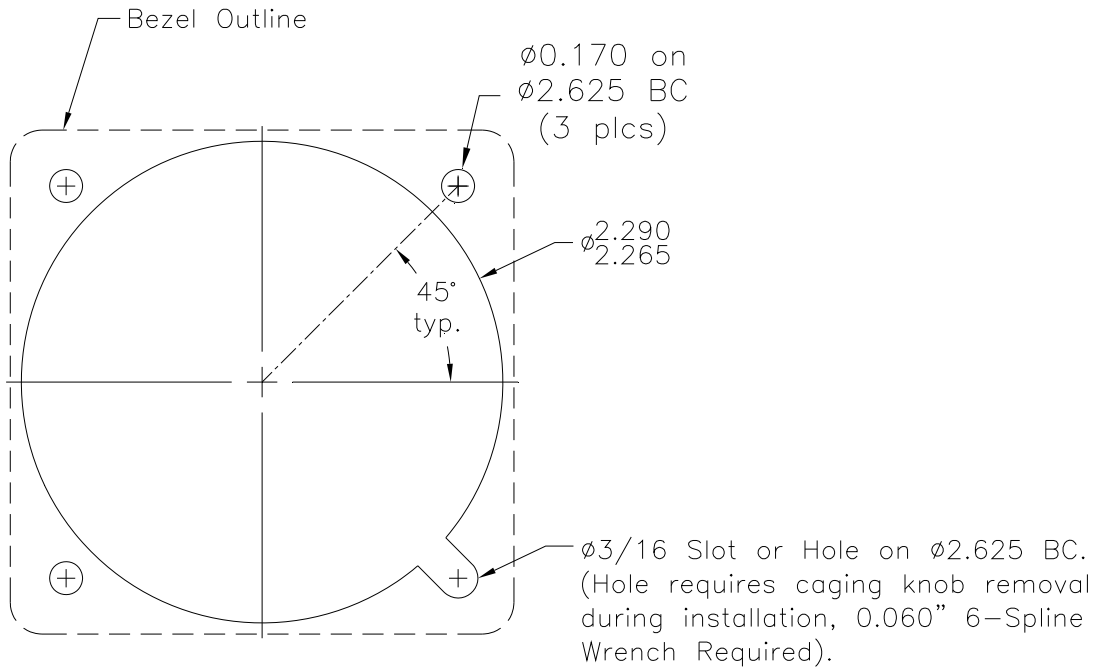

Rear Mount Panel Cutout

**Figure 2.2: Panel Cutout Dimensions**

## Section 3: Operation

### 3.1 General

This section describes the Model 4200 Electric Attitude Indicator operating procedures. The indicator is required to be installed in an aircraft with the specified inputs applied. Figure 1.2 provides an illustration of a typical Model 4200 display and a table describing indicator functions.

### 3.2 Starting Procedures

The following operational procedures are recommended when preparing the indicator for use:

**CAUTION: THE INDICATOR MAY BE DAMAGED IF THE "PULL TO CAGE" KNOB IS RELEASED WITH A "SNAP." RELEASE "PULL TO CAGE" KNOB AVOIDING A "SNAP" RELEASE.**

- NOTE: Indicator may be momentarily caged by pulling "PULL TO CAGE" knob to the fully extended position, holding knob until the display stabilizes, and then allowing the knob to return to the normal position.
- A. Apply power to the indicator. Note that the Gyro Warning flag (red) will pull out-of-view. Also allow three minutes for presentation stabilization.
  - B. For trim adjustment, use a 5/64" hex drive wrench to loosen the lock screw. Slide the screw up or down in the slot to the desired pitch attitude presentation (aligning the symbolic airplane with the horizon) and retighten the screw.
  - C. If caging is required, caging should be accomplished when the aircraft is in a wings level, normal cruise attitude, as indicated by other instruments or the horizon. If the gyro is caged when the aircraft is not in this attitude, the resulting attitude presentation immediately after caging will be in error by the difference between true vertical and actual aircraft attitude. Small errors in caging erection will be corrected by the indicator to true vertical in pitch and roll at 2.5° per minute minimum (5°/min. nominal).

### 3.3 In-Flight Procedures

- A. Adjust symbolic airplane to obtain desired pitch attitude presentation after take-off.
- B. In the event of errors in excess of 10° caused by extended bank or fore-aft acceleration, the indicator should be momentarily caged after the aircraft is returned to level flight.

### 3.4 Dynamic Errors

- A. Turn Induced Errors

Pitch indication errors resulting from a standard coordinated turn (180 degrees in one minute at a true airspeed of 156 knots) will not exceed 3°. Dynamic errors developed under non-standard conditions may be greater. Errors that develop will be self corrected by the internal erection system or manually corrected by the actuation of the caging system.

## Mid-Continent Instruments and Avionics, Wichita, KS

### B. Acceleration & Deceleration Errors

Pitch indicating errors may occur due to accelerations experienced during takeoff, climb-out, descent, and landing. Errors that develop will be self-corrected by the internal erection system or manually corrected (in straight and level flight) by the actuation of the caging system.

### C. Taxiing Errors

A pitch and roll indicator display error of approximately  $1^\circ$  will occur during a sudden  $90^\circ$  ground turn. A pitch indicator display error of approximately  $2^\circ$  will occur during a sudden  $180^\circ$  ground turn. Errors that develop will be self corrected by the internal erection system or manually corrected by the actuation of the caging system.

Configuration		
Dash #	Symbolic Airplane	Indicator Assy
-10	Traditional	9016154-10
-11	Delta	9016154-11

Revisions				
ECO	Rev.	Description	Date	Approved
	1	Initial Release.	4/10/05	JBR/BAW
	A	Production Release. Change numerous items.	8/23/05	JBR/BAW
4535	B	Update Current Rating: 1.4A was 1.2A, 0.37-0.51A was 0.35A±15%, 0.18-0.25A was 0.18A±15%.	2/3/06	JBR/BAW
5056	C	Update RTCA DO-160 HIRF qualification from [WW] to [WF] and lightning from [A3C3] to [A3H33]. Add note 2.	7/30/08	MKN/NL

Logo and company name have been changed in title block only. No functional or technical changes have been made. Revision remains unchanged.

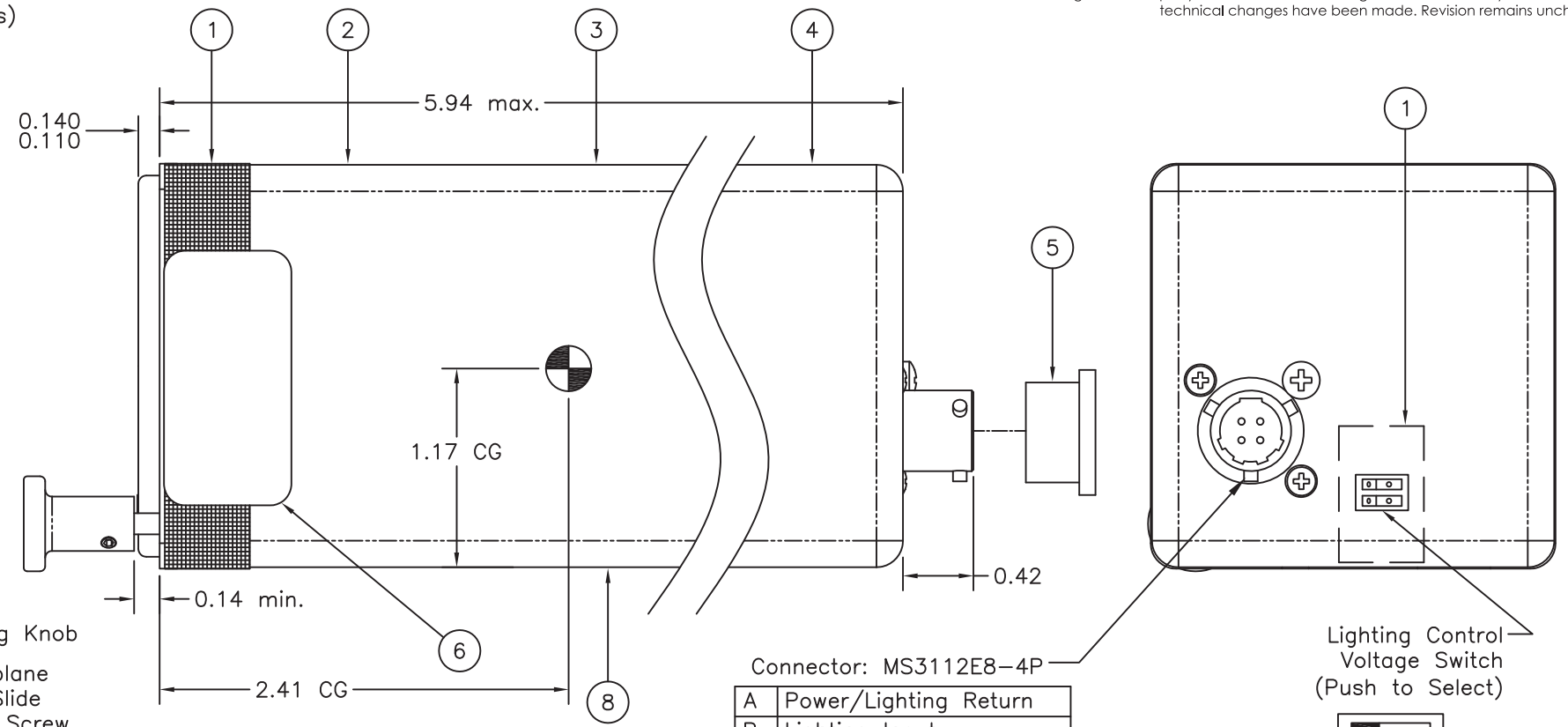
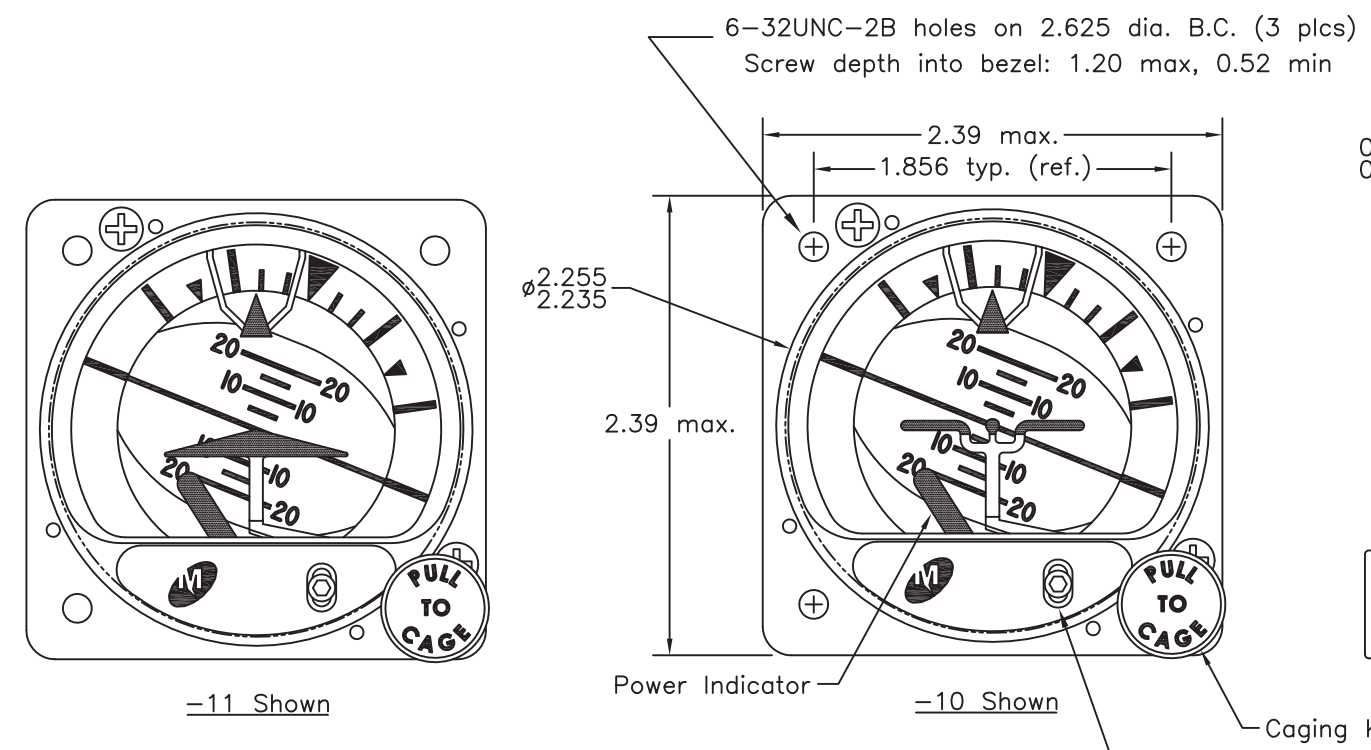

Connector: MS3112E8-4P

A	Power/Lighting Return
B	Lighting Input
C	+10VDC to 32VDC Input
D	Not Used

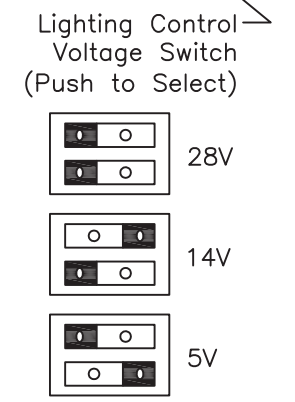

Specifications	
<b>Power Input</b>	10 to 32 VDC
<b>Current Rating</b>	At 13.75 VDC   Start: 1.4A Max   Run: 0.37-0.51A At 27.5 VDC   Start: 0.6A Max   Run: 0.18-0.25A
<b>Lighting</b>	Internal White LED. Lighting control voltage is selectable for 5V, 14V or 28V DC.
<b>Panel Tilt</b>	0° to 20°, set to customer requirements.
<b>Weight</b>	1.6 lbs.
<b>MTBF</b>	2500 hours
	FAA TSO-C4c
<b>Qualification Tests</b>	RTCA DO-160D Environmental Category C1BABXXXXXXZZA[ZWF]M[A3H33]XXA
<b>Temperature</b>	-30°C to +70°C Operating
<b>Altitude</b>	-1000 to +35,000 Ft. 41,000 Ft Decompression
<b>Connector</b>	MS3112E8-4P
<b>Mating Connector</b>	MS3116F8-4S or equivalent (P/N 9015514)
<b>Color</b>	Index Marks and Text: White Dial Background: Blue (top half)/Brown (bottom half) Roll Pointer & Symbolic Airplane: Orange Bezel: Black Power Indicator: Red
<b>Display Configuration</b>	Dials As Shown: Rotating roll dial/fixed roll pointer. Symbolic Airplane: Delta or Traditional configuration.
<b>Cover Glass</b>	HEA (Anti-Reflective) Coated

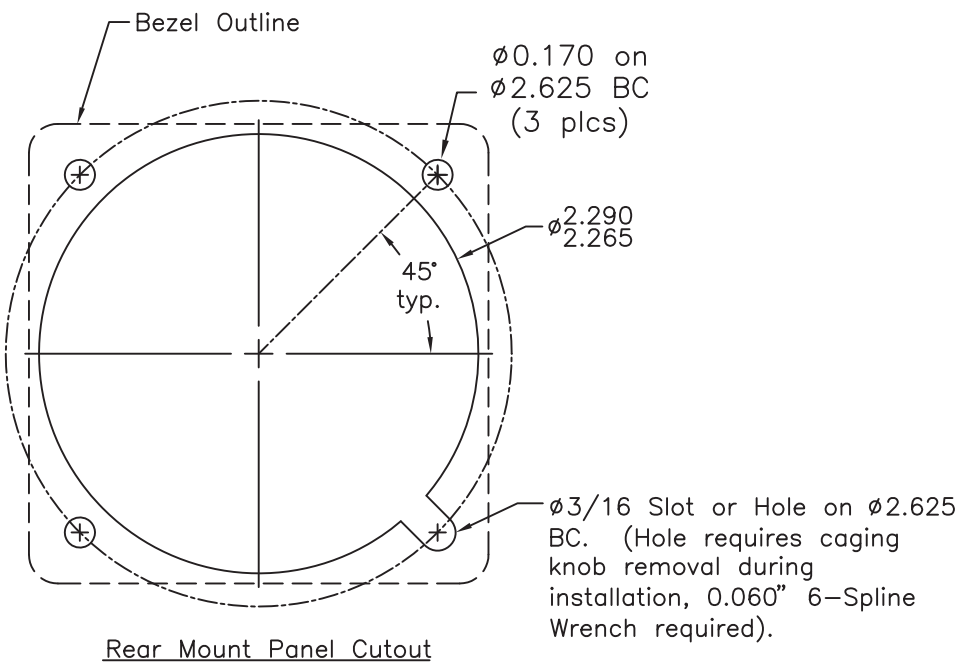

- Note:
- 1) Bezel/Cover seam and lighting voltage switch shall be covered with acetate tape for dust protection.
  - 2) Modification Status:  
MOD 1: N/A  
MOD 2: updated RTCA DO-160 HIRF and lightning qualifications

UNLESS OTHERWISE SPECIFIED, ALL DIMENSIONS ARE IN INCHES.  
TOLERANCE:  
FRACTIONAL=±1/64  
.XX=±0.015  
.XXX=±0.005  
.XXXX=±0.002  
ANGULAR=±0.5°  
CONCENTRICITY: 0.005 TIR  
BREAK ALL SHARP EDGES  
THREADS PER MIL-S-7742

DRAWN:  
J. Reed  
4/10/05  
  
APPROVED:  
BAW  
4/11/05

This document discloses proprietary information of Mid-Continent Instrument Co. It may be reproduced or disclosed only with written permission of Mid-Continent Instrument Co. and is not to be used in any way detrimental to the interests of Mid-Continent Instrument Co.



Item	Qty	Part Number	Description
1	A/R	8017360	Tape, Acetate
2	1	6018865	Decal, Caution
3	1	9016156-1	Nameplate
4	1	9016157-1	Decal, Tilt/Ltg
5	1	8012486-10YF	Cover, Connector
6	1	6018956	Decal, Warranty
7	1	9015514	Mating Connector
8	1	See Config.	Attitude Indicator Assy

TITLE: Attitude Indicator, Electric  
PART NUMBER: 4200-1( )  
SCALE: None  
DO NOT SCALE THIS DRAWING  
SHEET 1 of 1