

## Installation Manual and Operating Instructions

### Model TI250 Series Static Electrical Power Inverter



**True Blue Power®** is a division of Mid-Continent Instrument Co., Inc.

Mid-Continent Instrument Co., Inc.  
dba Mid-Continent Instruments and Avionics  
9400 E. 34<sup>th</sup> Street N.  
Wichita, KS 67226  
PH (800) 821-1212 FX (316) 630-0723

Manual Number 9018067  
Rev D, January 2, 2015

## FOREWORD

This manual provides information intended for use by persons who, in accordance with current regulatory requirements, are qualified to install this equipment. If further information is required, please contact:

True Blue Power  
c/o Mid-Continent Instrument Co., Inc.  
Attn: Customer Service Dept.  
9400 E. 34th Street N.  
Wichita, KS 67226 USA  
PH (316) 630-0101  
FX (316) 630-0723  
[www.truebluepowerusa.com](http://www.truebluepowerusa.com)  
[www.mcico.com](http://www.mcico.com)

We welcome your comments concerning this manual. Although every effort has been made to keep it free of errors, some may occur. When reporting a specific problem, please describe it briefly and include the manual part number, the paragraph/figure/table reference and the page number. Send your comments to:

True Blue Power  
c/o Mid-Continent Instrument Co., Inc.  
Attn: Technical Publications  
9400 E. 34th Street N.  
Wichita, KS 67226 USA  
PH (316) 630-0101  
FX (316) 630-0723

All products produced by Mid-Continent Instrument, Co., Inc., including those identified as Mid-Continent Instruments and Avionics or True Blue Power, are designed and manufactured in Wichita, KS, USA.

© Copyright 2015  
Mid-Continent Instrument Co., Inc.

## REVISION DETAIL

Revision	Date	Approved	Detail
A	12/10/13	BAW	Initial release
B	02/11/14	BMC	Revised Technical Specifications
C	05/27/14	BMC	Revised Section 3.3.1, Wire Gauge Selection
D	01/02/15	BMC	Added TI254 and TI256 models

## TABLE OF CONTENTS

<b>SECTION 1</b>	<b>GENERAL DESCRIPTION</b>	
1.1	INTRODUCTION	5
1.2	TECHNICAL SPECIFICATIONS	5
1.2.1	Electrical Attributes	5
1.2.2	Physical Attributes	5
1.2.3	Qualifications	5
<b>SECTION 2</b>	<b>INSTALLATION CONSIDERATIONS</b>	
2.1	COOLING	6
2.2	EQUIPMENT LOCATION	6
2.3	ROUTING OF CABLES	6
2.4	LIMITATIONS	6
<b>SECTION 3</b>	<b>INSTALLATION PROCEDURE</b>	
3.1	GENERAL INFORMATION	7
3.2	UNPACKING AND INSPECTING	7
3.3	CABLE HARNESS	7
3.3.1	Wire Gauge Selection	7
3.3.2	Pin Assignment Information	7
3.3.3	Harness Verification	11
3.4	MOUNTING	11
3.5	INSTALLATION COMPLETION	12
<b>SECTION 4</b>	<b>OPERATION</b>	
4.1	ELECTRICAL PERFORMANCE	14
4.2	PROTECTIVE FEATURES	14
4.2.1	Remote On/Off	14
4.2.2	Over-Voltage	14
4.2.3	Under-Voltage	14
4.2.4	Over-Temperature	14
4.2.5	Short Circuit and Over-Current	14
4.2.6	Ground Fault Protection	15
4.2.7	Fault Shutdown and Indication	15
<b>SECTION 5</b>	<b>CONFORMANCE</b>	
5.1	CONTINUED AIRWORTHINESS STATEMENT	16
5.2	ENVIRONMENTAL QUALIFICATION STATEMENT	16
<b>NUMBER</b>	<b>LIST OF TABLES AND FIGURES</b>	
1.1	Electrical Attributes Table	6
1.2	Physical Attributes Table	6
1.3	Performance Table	6
3.3	Connector Pinout Figure	9
3.4	Example Wiring Diagrams	10
3.5	TI250 Outline Drawing Figure	13

## SECTION 1 GENERAL DESCRIPTION

### 1.1 INTRODUCTION

The model TI250 Series Static Electrical Power Inverter is a lightweight power inverter that translates a 20 to 36 VDC input to three various output options:

Model	Part Number	Output
TI250	6430250-1	115 VAC, 60 Hertz
TI254	6430250-2	115 VAC, 400 Hertz
TI256	6430250-3	115/26 VAC, 400 Hertz

All three configurations provide 250 watts (VA) of power. The alternating current output is defined as a pure sine wave with less than 2% of total harmonic distortion for clean, noise-free, harmonic-free power to supply loads of corresponding voltage, power and frequency. For the TI250, the 115VAC, 60 Hertz (Hz) is suitable for nearly any common commercial or consumer load rated for a nominal input of 110-120VAC. The TI254 and TI256 are designed for 115VAC outputs with an AC frequency of 400 Hz for common avionics and related equipment, with the TI256 also providing an additional independent 26VAC output. The TI250 Series Static Inverter is FAA certified to TSO C73 and tested to rigorous environmental standards and levels of RTCA DO-160. The small size and light weight in conjunction with its installation flexibility (inside or outside the pressure vessel) make it an ideal choice for aircraft power needs while reducing the challenges associated with other similar products.

Highlighted features include short circuit protection, overload capability, low voltage shut-down, temperature monitoring, a self-resettable over-temperature disable, a remote on/off function, and a fault indication output. The TI250 Series has the same connector of legacy designs plus ground fault interrupter protection. The rugged extrusion that houses the unit is designed to help dissipate heat and provide mechanical strength against vibration or other possibilities of damage. The TI250 Series is engineered to run cooler and requires no active cooling, featuring a fanless design, which saves energy, reduces weight and allows flexible installation locations. At only 2.5 pounds or less, it is lighter and smaller than competing inverters. Additionally, the primary stage of the TI250 Series utilizes current mode control for increased reliability and safety.

### 1.2 TECHNICAL SPECIFICATIONS

Electrical Attributes:	Model TI250	Model TI254	Model TI256
Input Voltage:	Rated 28VDC nominal; 20-36VDC certified		
Input Current (full load):	9 amps nominal; 13 amps max		
Input Current (no load)	150 milliamps		
Input Current (ON/OFF = OFF)	50 milliamps		
Recommended Circuit Breaker:	15 amps		
Output Voltage:	115VAC $\pm$ 3% at 60 Hertz $\pm$ 0.1%	115VAC $\pm$ 3% at 400 Hertz $\pm$ 0.1%	115/26VAC $\pm$ 3% at 400 Hertz $\pm$ 0.1%
Output Power:	250 watts (250 VA at power factor = 1)		
Output Waveform:	Single phase, pure sine wave		
Power Factor:	-0.8 to +0.8		
Efficiency:	87 – 90% nominal		
Total Harmonic Distortion (THD):	Less than 2%		

**Table 1.1**

<b>Physical Attributes:</b>	<b>Model TI250</b>	<b>Model TI254</b>	<b>Model TI256</b>
Weight:	2.2 lbs (1 kg)	2.2 lbs (1 kg)	2.6 lbs (1.15 kg)
Dimensions: (not including connector mate)	6.7 inches long x 6.0 inches wide x 2.0 inches high (171 mm long x 152 mm wide x 51 mm high)		
Mating Connector (and cable clamp):	MS3106A-18-9S (MCI P/N 9016905-1, -2)		
Mounting:	Base mount – orientation not critical		

**Table 1.2**

<b>Qualifications:</b>	<b>Model TI250</b>	<b>Model TI254</b>	<b>Model TI256</b>
Certification:	FAA TSO-C73		
Environmental Qualification:	RTCA DO-160G Environmental Category; See Section 5.2		
Altitude:	-15,000 feet to +55,000 feet		
Temperature:	-55°C to +70°C (-67°F to +158°F)		

**Table 1.3**

## SECTION 2 PRE-INSTALLATION CONSIDERATIONS

### 2.1 COOLING

The TI250 Series does not require external cooling or contain internal active cooling. Cooling of the unit occurs exclusively through passive conduction through the base or radiated cooling across the metal case. Additional cooling can be realized through convective effects of the environment (exposure to free moving air). These methods are not required to achieve rated performance but can help prevent potential overheating and extend life when the unit is operated at full power or during overload conditions. Specifically, mounting the unit to a metal surface is preferred, but not required.

### 2.2 EQUIPMENT LOCATION

The TI250 Series is designed for mounting flexibility, allowing for installation inside or outside the pressure vessel with no requirement for temperature control. In addition to altitude and temperature resistance, the unit is also designed to withstand high levels of condensing humidity. However, installation locations where the unit could be subject to standing or direct water exposure should be avoided. The unit can be mounted in any orientation. Clearance should be provided for the mating connector and may require as much as five inches past the unit connector to allow for back shell access to the connector.

### 2.3 ROUTING OF CABLES

The wires and cable bundle associated with the unit are heavy gauge wire and carry significant power. Be aware of routing cables near other electronics or with other wire bundles that may be susceptible to high energy flow.

Avoid sharp bends in cabling and routing near aircraft control cables. Also avoid proximity and contact with aircraft structures, avionics equipment, or other obstructions that could chafe wires during flight and cause undesirable effects.

### 2.4 LIMITATIONS

The TI250 Series of static electric power inverters is certified to FAA TSO-C73 with the following limitations identified:

- 1) Alternating current (AC) output is provided at 115 volts and 60 hertz in lieu of 115 volts and 400 hertz as identified in the MPS of the TSO.
- 2) Equivalent environmental qualification was verified per RTCA DO-160G in lieu of those identified within the MPS of the TSO.

The conditions and tests for TSO approval of this article are minimum performance standards. Those installing this article, on or in a specific type or class of aircraft, must determine that the aircraft installation conditions are within the TSO standards, specification of the article, and deviations as listed above. TSO articles must have separate approval for installation in an aircraft. The article may be installed only according to 14 CFR part 43 or the applicable airworthiness requirements.

## SECTION 3 INSTALLATION PROCEDURES

### 3.1 GENERAL INFORMATION

This section contains interconnect diagrams, mounting dimensions and other information pertaining to the installation of the TI250 Series Static Inverter. After installation of cabling and before installation of the equipment, ensure that power is applied only to the pins specified in the interconnect diagram.

### 3.2 UNPACKING AND INSPECTING EQUIPMENT

When unpacking this equipment, make a visual inspection for evidence of any damage that may have incurred during shipment. The following parts should be included:

- |                                     |                                 |
|-------------------------------------|---------------------------------|
| a. Static Inverter                  | MCI P/N 6430250-( )             |
| b. Mating Connector (& cable clamp) | MCI P/N 9016905-1 and 9016905-2 |
| c. Installation Manual              | MCI P/N 9018067                 |

Equipment not provided:

- |                       |   |
|-----------------------|---|
| a. Mounting Hardware  | four (4) ¼-20 pan head screws<br>¼" lock washers (optional) |
| b. Cable Harness Wire | See Section 3.3 for specifications                          |

### 3.3 CABLE HARNESS

Construct the cable harness with regards to the instructions below, and using the Connector Pinout of Figure 3.3, Figure 3.4, and Wiring Diagram of Table 3.3.

Refer to Section 2: Pre-Installation Considerations in regards to routing precautions.

#### 3.3.1 Wire Gauge Selection

Use of PTFE, ETFE, TFE, Teflon, or tefzel insulated wire is recommended for aircraft use. Use the following wire gauges for each of the pins in the connector:

Pin A and D – 12-14 AWG stranded or solid  
Pin B and C – 18-20 AWG stranded or solid  
Pin E and F – 18-24 AWG stranded or solid

Suggestion: If the TI250 is installed in an application where the pin-compatible 500 Watt MD50 inverter may be later used; the larger wire gauge sizes of the MD50 can be used.

#### 3.3.2 Pin Assignment Information

##### INVERTER INPUT POWER:

**Positive DC input** – +24 to 32 VDC. Connect to the aircraft 28 VDC bus using a 15 Amp circuit breaker.

**Negative DC input** – Connect to aircraft ground.

Note: Two common practices for the connecting the -28V of power devices in aircraft are:

1. The negative lead connects from the device to the negative power bus.
2. The negative lead connects from the device to the negative power bus, and a second lead connects to the aircraft structure close to the power device.

The TI250 Series passes DO160G Section 21 Table 1.2.3 conducted emissions testing using both methods.



**INVERTER AC OUPUT:**

**AC Return** – Used for powering devices where terrestrial/utility power designations are used, pin C can be connected as “Neutral”.

**AC Output** – Used for powering devices where terrestrial/utility power designations are used, pin B can be connected as “Line” or “Hot”.

**Note: Use of a circuit breaker on the AC output is optional. For the full output of 250VA, a 2.5 Amp circuit breaker is sufficient. For convenience at each AC outlet, individual circuit breakers of 1 to 3 amps each can be used. If a single pole breaker is used, install the breaker on the wire from pin B. If a double pole breaker is installed, route both pins B and C through the circuit breaker.**

**INVERTER REMOTE ON/OFF CONTROL:** (see section 4.2.1)

**Remote ON/OFF Control** – Connecting this pin to either DC Negative or to aircraft ground will enable the AC output of the inverter. By utilizing a switch between this pin and ground or negative, it will allow remote on/off control of the unit. When unconnected (output is OFF) this pin will have approximately 16 VDC present, internally limited to less than 3 mA. If the inverter is to be enabled at all times, pin E can be connected to pin G.

**Remote ON/OFF Return** – This pin is internally connected to pin D. Pin G may be used as the return from an ON/OFF switch or left unconnected. It is recommended that pin G not be connected directly to ground or 28V negative.

**INVERTER FAULT INDICATION OUTPUT:**

**Fault Indication Output** – This pin can be connected to an external LED or status monitoring device to indicate the operating status of the inverter. The inverter will provide Fault indication when: Power Output capability has been exceeded, the output has been short-circuited, the output is ground-faulted (GFI protection activated), or the inverter has shut-down in over-temperature protection. The output is an open-collector transistor with a weak pull-up to 28V (21K ohm) capable of sinking 100 mA.

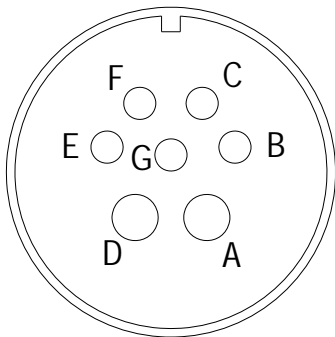

**Figure 3.3**

**Pinout View of Unit Connector**

	Connector Pinout		
	TI250, TI254	TI254	TI256
A	24-32VDC Input	24-32VDC Input	24-32VDC Input
B	115VAC Output	115VAC Output	115VAC Output
C	AC Return	AC Return	AC Return
D	DC Return	DC Return	DC Return
E	Remote On/Off	Fault Indication	Fault Indication
F	Fault Indication	Remote On/Off	Remote On/Off
G	Remote Return	Remote Return	26VAC Output

**Table 3.3**

**Connector Pinout**

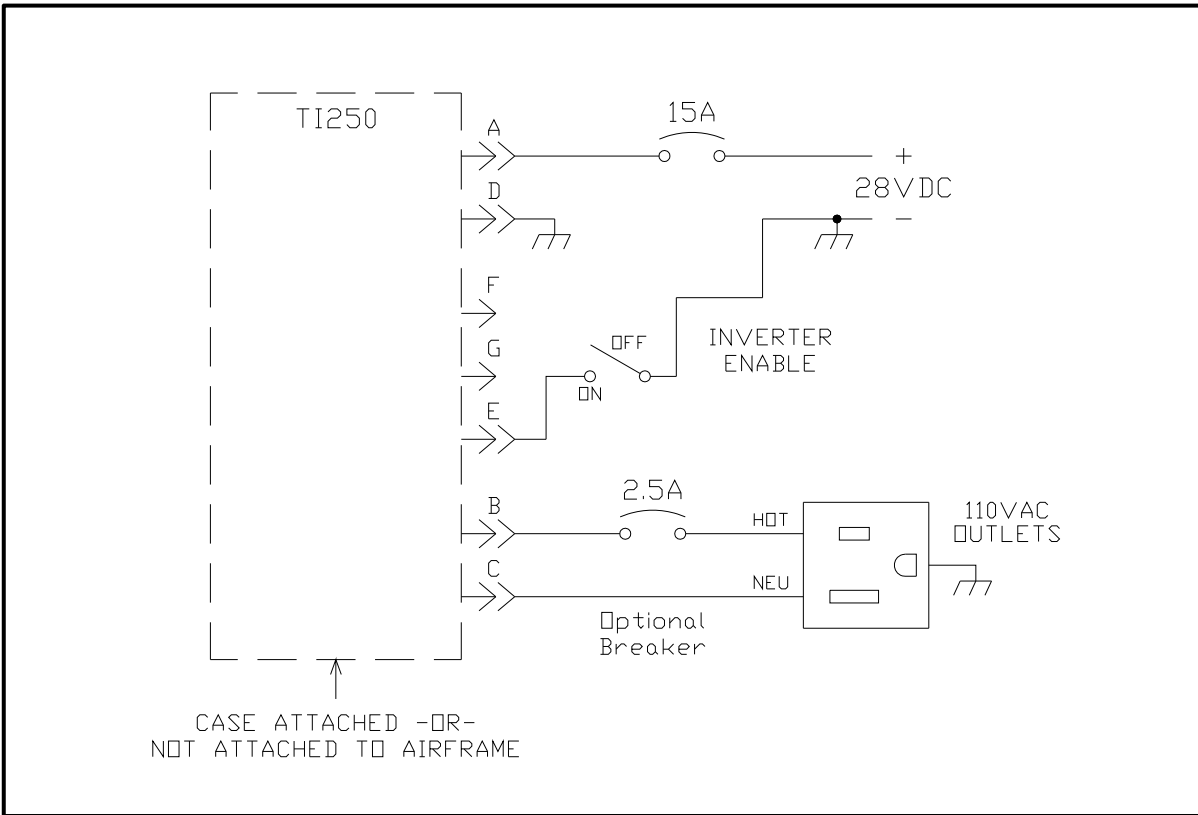

**Figure 3.4A: Typical TI250 Small Aircraft Minimum Wiring Installation**

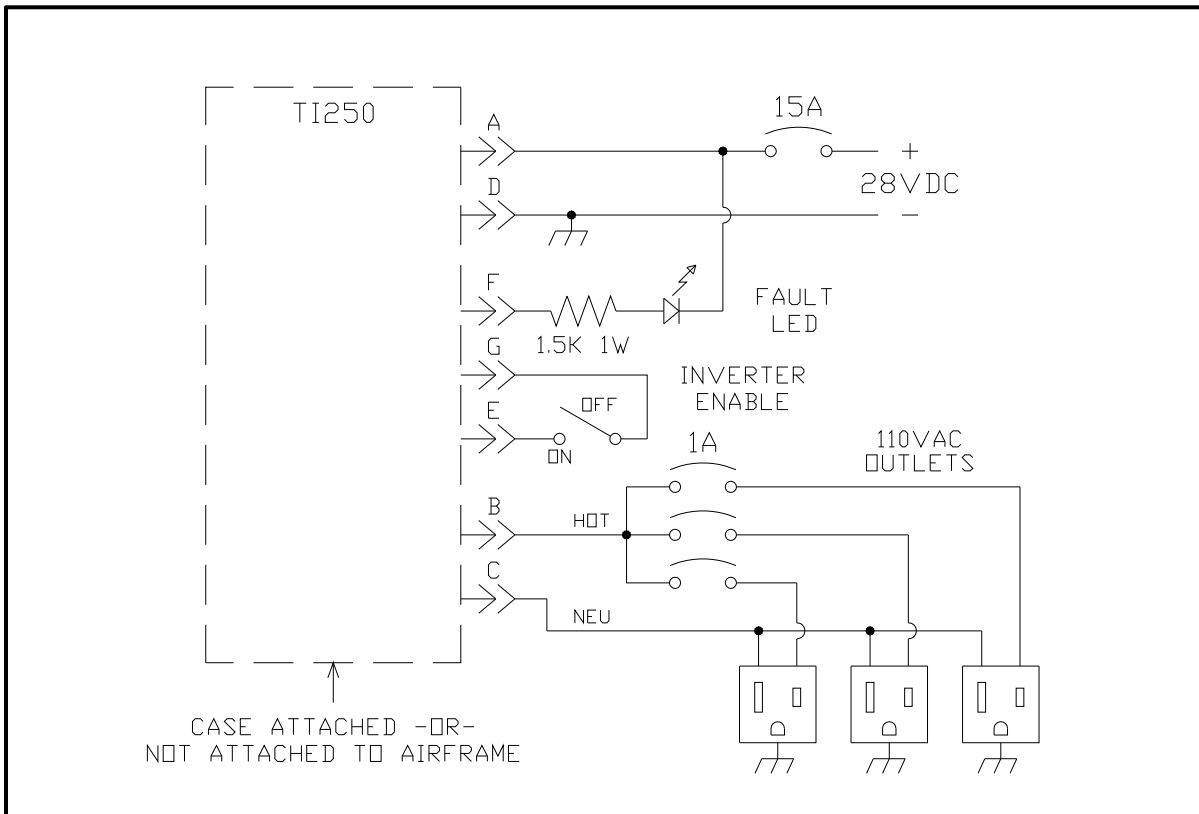

**Figure 3.4B: Typical TI250 Aircraft Wiring Installation**

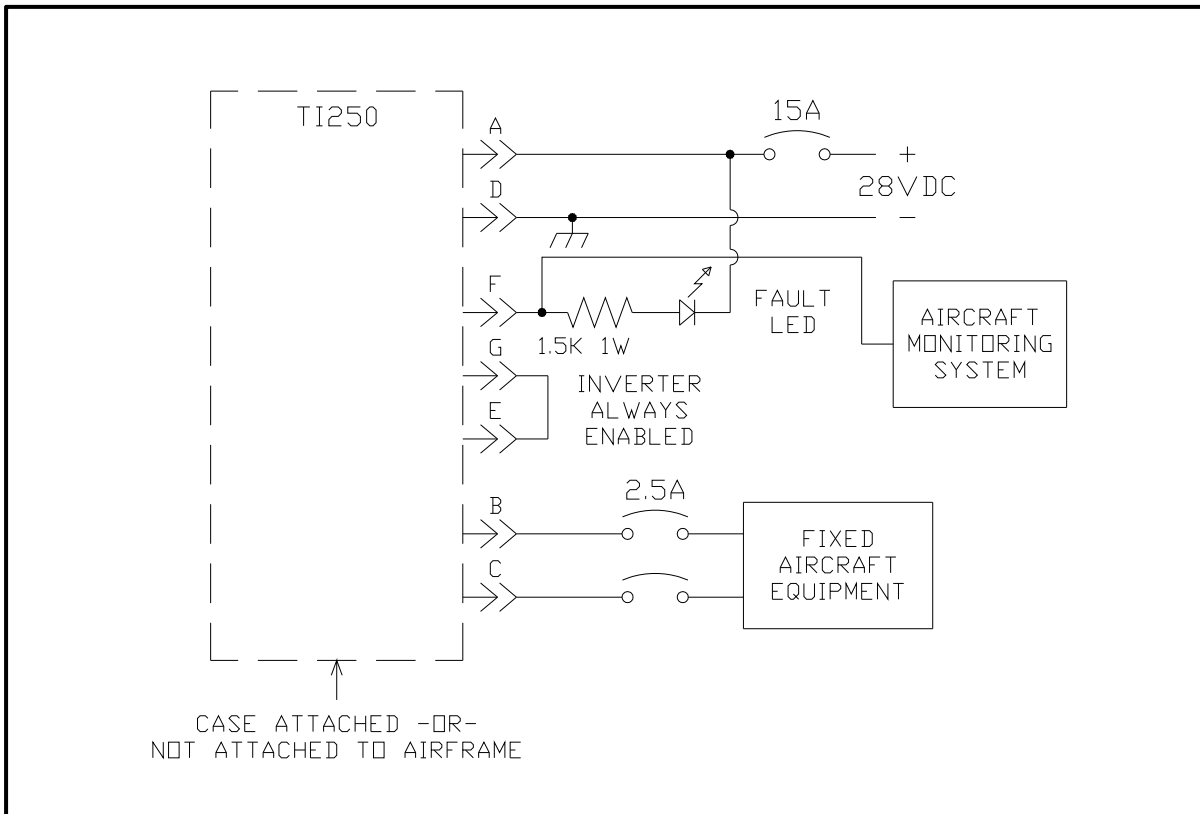

**Figure 3.4C: Typical Installation (60 or 400 Hz; Fixed Equipment)**

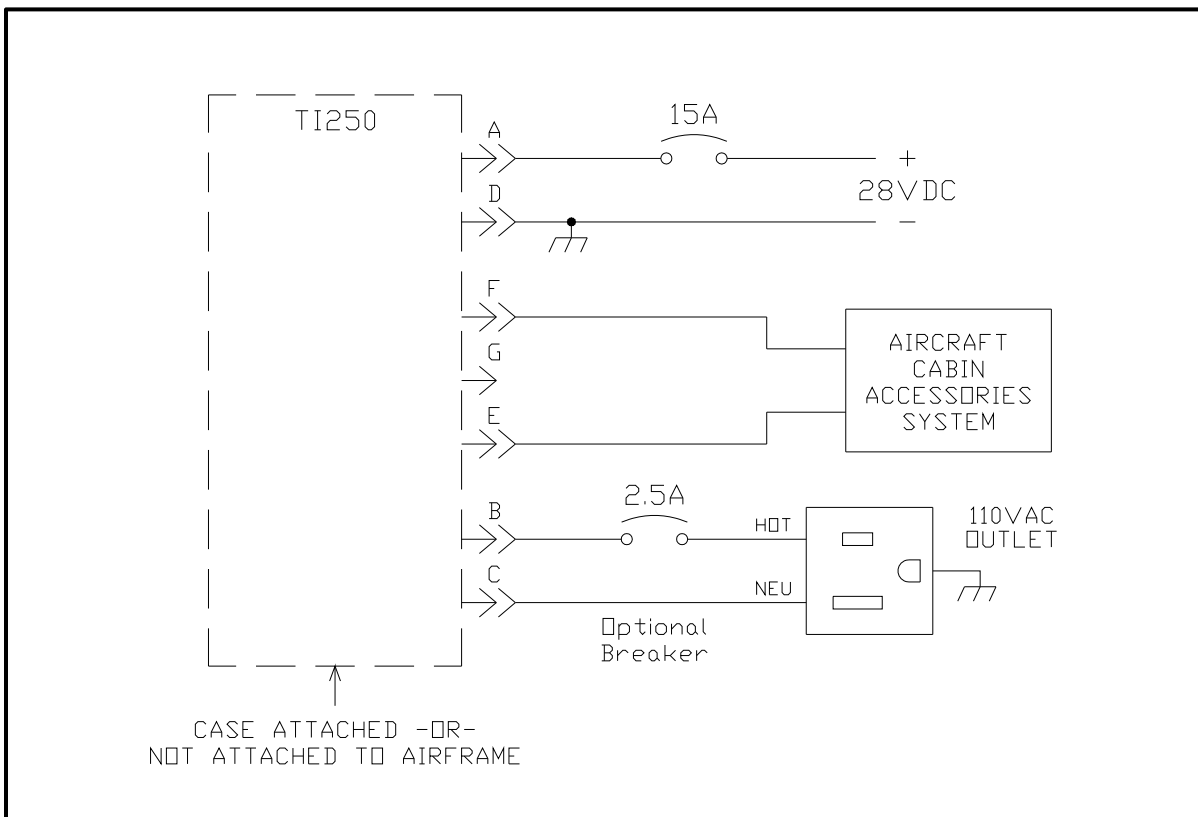

**Figure 3.4D: Fully-Integrated Multi-Inverter Aircraft Cabin System**

### **3.3.3 Example Wiring Diagrams**

The inverter is flexible in the wiring installation allowing for it to be integrated into the aircraft according to the application needs. Several examples are shown in the diagrams.

### **3.3.4 Harness Verification**

With the TI250 Series Static Inverter disconnected, activate the aircraft power bus that supplies the unit and use a multi-meter to verify that aircraft power and ground with appropriate voltage is on the pins within the mating harness.

## **3.4 MOUNTING**

Refer to Section 2: Pre-Installation Considerations in regards to equipment location.

The TI250 Series Static Inverter is designed for base mounting only. Four ¼-20 mounting holes should be provided in the aircraft in accordance with Figure 3.5. Secure the unit with four ¼-20 pan head Phillips screws, or equivalent. A lock washer under the head of each screw is recommended.

## **3.5 INSTALLATION COMPLETION**

Prior to operating the unit in the aircraft, it is recommended to verify the output and functionality of the unit. In order to prevent accidental damage to other systems, it is best not to attach the output to other equipment or power busses prior to verification. Verify the output of the unit at the terminating end of the cable with a multi-meter to ensure proper voltage and polarity. Once verified, installation can be completed and functionality of the remote on/off feature (if used) should be checked.

## **3.6 INSTALLATION CAUTION**

Do not connect the output of the TI250 Series Static Inverter to the output of any other inverter or damage will result. Under no circumstance allow the output of the inverter to be connected to ground utility AC power or damage will result. If more than 250 watts of power is required for an installation, a higher power inverter model such as the 500 watt Mid-Continent MD50 should be selected.

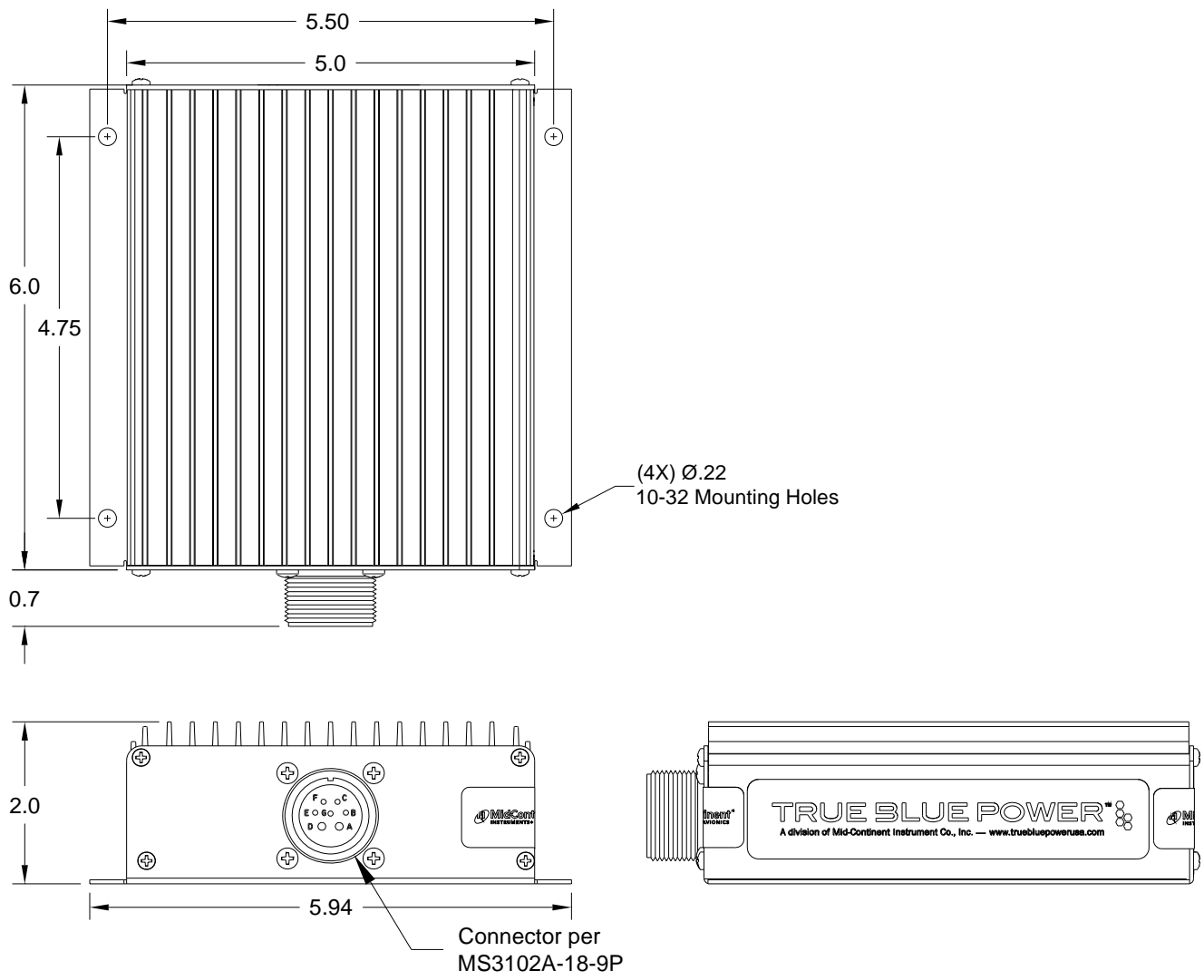

**Figure 3.5**  
**TI250 Series Static Inverter Outline Drawing**

## SECTION 4 OPERATION

### 4.1 ELECTRICAL PERFORMANCE

The TI250 Series Static Inverter converts a direct current (DC) voltage input to a regulated VAC output; the output is controlled to an established frequency and represents a pure sine wave with minimal distortion. See Table 4.1 specific output and frequency.

Model	Input	Output	Frequency
TI250	20-36 VDC	115 VAC	60 Hz
TI254	20-36 VDC	115 VAC	400 Hz
TI256	20-36 VDC	115/26 VAC	400 Hz

**Table 4.1**  
**TI250 Series Electrical Performance**

The unit is capable of providing 250 watts to power a variety of aircraft accessories including laptops, personal electronics, and onboard systems. (See Section 1.2.1 for tolerance ranges)

The unit is designed as a two-stage, solid-state switch-mode power supply. The power transformation utilizes a first-stage push-pull methodology followed by an H-bridge AC forming second stage. The primary stage utilizes 'current-mode' control providing instantaneous load protection as an advantage over legacy designs that incorporate 'voltage-mode' controllers. Additionally, the AC output stage controls both the current and voltage of the output AC waveform providing a low-distortion sine wave output even over varying power factor requirements of the load. The AC output is frequency controlled using a crystal oscillator reference.

### 4.2 PROTECTIVE FEATURES

#### 4.2.1 Remote On/Off

The TI250 Series Static Inverter incorporates a remote on/off feature that allows the user to enable or disable the output of the unit. By providing a ground on the appropriate pin (See Table 3.3) the user, via a remote mounted switch, can enable the output of the unit. The unit can be similarly disabled by removing the ground signal (open circuit) to the same pin. The remote on/off control of the inverter is also used to reset the inverter should an over-current or GFI fault condition occur.

#### 4.2.2 Over-Voltage

When the input voltage exceeds the operating range of the unit (See Section 1.2.1; absolute maximum input of 36VDC) the unit senses an over-voltage condition and disables the output. The unit will dynamically monitor the input voltage such that if the input returns to within the normal operating range, the output will be enabled and allow the unit to operate normally. Over-voltage will not activate the fault status output.

#### 4.2.3 Under-Voltage

When the input voltage drops below the operating range of the unit (See Section 1.2.1; absolute minimum input of 20VDC) the unit senses an under-voltage condition and disables the output. The unit will dynamically monitor the input voltage such that if the input returns to within the normal operating range, the output will be enabled and allow the unit to operate normally. Under-voltage will not activate the fault status output.

#### 4.2.4 Over-Temperature

The TI250 Series Static Inverter incorporates an internal temperature sensing device that continually provides monitoring and feedback to the control circuits. When the unit senses an internal condition that exceeds maximum temperature ratings, the output is disabled and the fault output will indicate. The inverter will continue to remain shut-down in a fault condition

until the temperature returns to within acceptable limits. This over-temperature reset occurs automatically without external intervention required.

#### **4.2.5 Short Circuit And Over-Current**

The TI250 Series Static Inverter is capable of surviving a short circuit or over-current event without permanent damage or effect to long-term reliability. The unit can provide over its rated power output up to 375 watts for over 30 minutes (until over-temperature shutdown occurs).

The inverter monitors the AC output on a pulse-by-pulse scenario to determine a short-circuit or over-current situation. If detected, the output is limited by clipping the AC sine waveform, limiting the power output. If the short-circuit or over-current situation continues for more than a few seconds, the inverter will turn-off the AC output and indicate a fault on the fault output line.

#### **4.2.6 Ground Fault Protection**

The TI250 Series Static Inverter monitors the AC output for indications of current imbalance between the two AC output lines. Should a ground fault be detected, the AC output will be disabled and the fault output will indicate. Remove all inverter loads before re-enabling the inverter.

#### **4.2.7 Fault Shutdown and Indication**

The TI250 Series Static Inverter monitors the AC output load, its internal temperature, and operation status. Should the load be excessive or the inverter become too hot, the inverter will disable the AC output and indicate a fault status on the fault output. If the inverter is in a fault state, a LED connected as shown in the wiring diagrams will be lit.

To reset the inverter and clear the fault: 1) Remove all inverter loads before re-enabling the inverter, 2) Re-enable the inverter by switching the inverter on/off to OFF for four seconds, and then back to ON. NOTE: If the inverter is over-temperature it will not re-enable until it has cooled. Fault can also be cleared by cycling power to the inverter.

## SECTION 5 CONFORMANCE

### 5.1 INSTRUCTIONS FOR CONTINUED AIRWORTHINESS

No periodic scheduled maintenance or calibration is necessary for continued airworthiness of the TI250 Series Static Inverter. If the unit fails to perform to specifications, the unit must be removed and serviced by Mid-Continent Instruments and Avionics or their authorized designee.

### 5.2 ENVIRONMENTAL QUALIFICATION STATEMENT

**PART NUMBER:** 6430250-( ) Series      **MODEL NUMBER:** TI250, TI254, TI256  
**NOMENCLATURE:** Static Electrical Power Inverter      **TSO NUMBER:** C73  
**MANUFACTURERS SPECIFICATIONS:** Test Specification (TS) 512, Test Data Sheet (TDS) 512  
**QUALIFICATION STANDARD:** RTCA DO-160G

CONDITIONS	SECTION	DESCRIPTION OF TEST
Temperature and Altitude	4	Category F3(Y)
Low Temperature	4.5.1	Operating Low Temp = -55C
High Temperature	4.5.2	Operating High Temp = +70C
In-Flight Loss of Cooling	4.5.5	Category Y = 300 minutes, +40C, 75%
Decompression	4.6.2	Altitude = +55,000 ft.
Overpressure	4.6.3	-15,000 ft.
Temperature Variation	5	Category S2
Humidity	6	Category B
Operational Shock and Crash Safety	7	Category B
Vibration	8	Category R; Curve C, C1 [(RCC1)] Category U; Curve G
Explosion	9	Category X
Waterproofness	10	Category X
Fluids	11	Category X
Sand and Dust	12	Category X
Fungus	13	Category X
Salt Spray	14	Category X
Magnetic Effect	15	Category Z
Power Input	16	Category Z
Voltage Spike	17	Category A
Audio Frequency Conducted Susceptibility	18	Category R
Induced Signal Susceptibility	19	Category (ZC)
Radio Frequency Susceptibility	20	Category (RR)
Emission of Radio Freq Energy	21	Category M
Lightning Induced Transient Susceptibility	22	Category A3 (pin injection) Category G3L3 (cable bundle) [A3G3L3]
Lightning Direct Effects	23	Category X
Icing	24	Category X
ESD	25	Category A
Flammability	26	Category X



Configuration			
Dash #	Model #	Assembly	Nameplate
-1	TI250	9017929	9018039-1
-2	TI254	9017929-1	9018039-2
-3	TI256	9017929-2	9018039-3
-4	TI256	9017929-3	9018039-3

Revision				
ECO	Rev.	Description	Date	Approved
		See previous drawing for revision history		
6366	F	Added -4 configuration and pinout.	03/19/15	BMC/CAS
6387	G	Remove "Power Output" from Config table, add "Nameplate". Added configs to Specifications table.	04/28/15	RMV/Sch

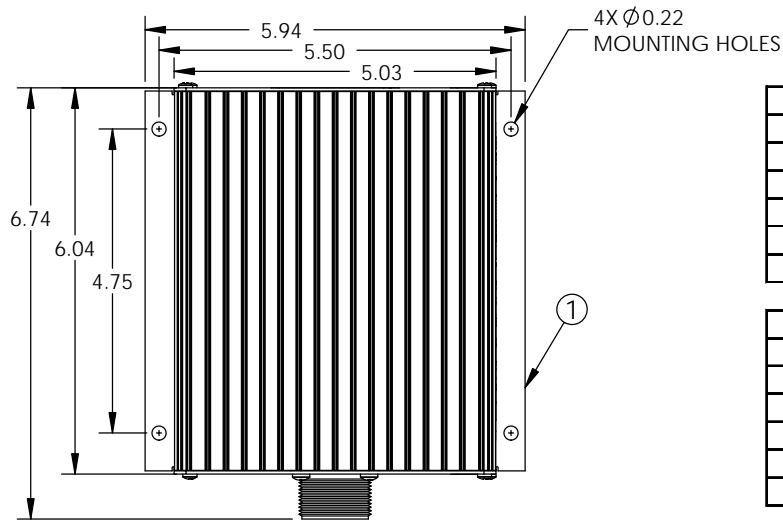
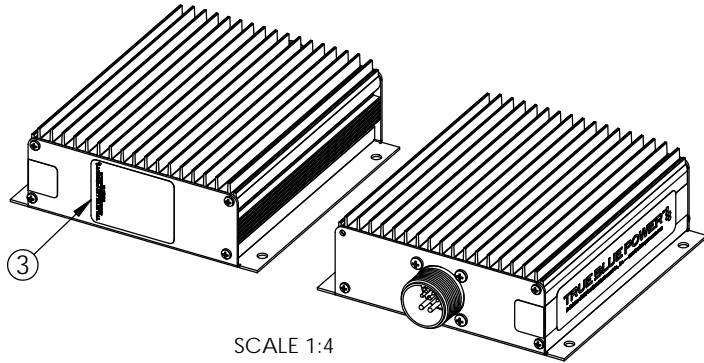

Connector Pinout		
	-1	-2
A	24-32VDC Input	24-32VDC Input
B	115VAC Output	115VAC Output
C	AC Return	AC Return
D	DC Return	DC Return
E	Remote On/Off	Fault Indication
F	Fault Indication	Remote On/Off
G	Remote Return	Reserved
	-3	-4
A	24-32VDC Input	DC Return
B	115VAC Output	AC Return
C	AC Return	Remote On/Off
D	DC Return	24-32VDC Input
E	Fault Indication	26VAC Output
F	Remote On/Off	Phase Sync
G	26VAC Output	115VAC Output

Specifications		
Model Number	See Configuration Table	
Power Input	20-36 VDC, 10 Amps nominal @ 28 VDC	
Power Output	Single Phase Sine Wave	
	-1	115 VAC, 60 Hz, 250 VA
	-2	115 VAC, 400 Hz, 250 VA
	-3/-4	115 VAC, 400 Hz, up to 250 VA 26 VAC, 400 Hz, up to 75 VA 250 VA combined total
Power Factor	-0.8 to +0.8	
Features	90% Efficiency, Remote ON/OFF, Harmonic Distortion under 1.5%	
Protection	Overtemp, Short Circuit, Undervoltage,	
Qualification	FAA TSO-C73; EASA ETSO-C73 RTCA DO-160G (See Installation Manual)	
Temperature	-55°C to +70°C	
Altitude	55,000 feet MAX	
Mating	MCIA p/n 9016905-1	
Connector	(MS3106A-18-9S or equivalent)	
Case	Anodized aluminum, blue	
Weight	(-1/-2)- 2.2 lbs; (-3/-4)- 2.6 lbs	

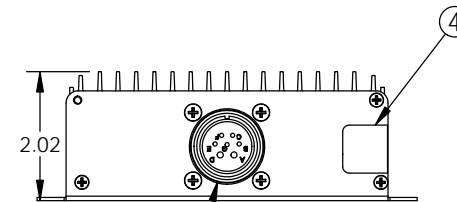

Connector per MS3102A-18-9P

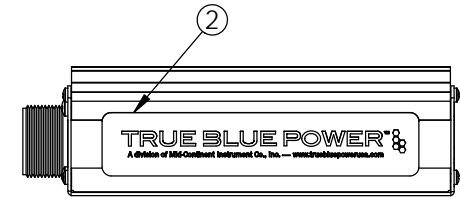

Item	Qty	Part Number	Description
1	1	See Config	Assembly, Components
2	1	9017130-1	Label, True Blue Power
3	1	See Config	Nameplate, TI25X
4	2	6018956-1	Decal, Warranty TBP

UNLESS OTHERWISE SPECIFIED, ALL DIMENSIONS ARE IN INCHES.  
TOLERANCE:  
FRACTIONAL=±1/64  
.XX=±0.015  
.XXX=±0.005  
.XXXX=±0.002  
ANGULAR=±0.5°  
CONCENTRICITY: 0.005 TIR  
BREAK ALL SHARP EDGES  
THREADS PER MIL-S-7742

DRAWN:  
JDS  
12/23/2013

APPROVED:  
MKN  
12/23/2013

This document discloses proprietary information of Mid-Continent Instrument Co., Inc. It may be reproduced or disclosed only with written permission of Mid-Continent Instrument Co. and is not to be used in any way detrimental to the interests of Mid-Continent Instrument Co., Inc.

**TRUE BLUE POWER**  
A Division of Mid-Continent Instrument Co., Inc.

TITLE:  
Inverter, 115VAC, 250VA, Sine Wave

PART NUMBER:  
6430250

SCALE: 1:3

DO NOT SCALE THIS DRAWING

SHEET: 1 of 1