



## JA40-001 Intercom Tie Line Isolation Transformer Data Sheet



### Description

The JA40 Intercom Tie Line Transformer allows up to 4 tie lines to be transformer coupled with a minimum crosstalk and noise interference.

### Typical Application

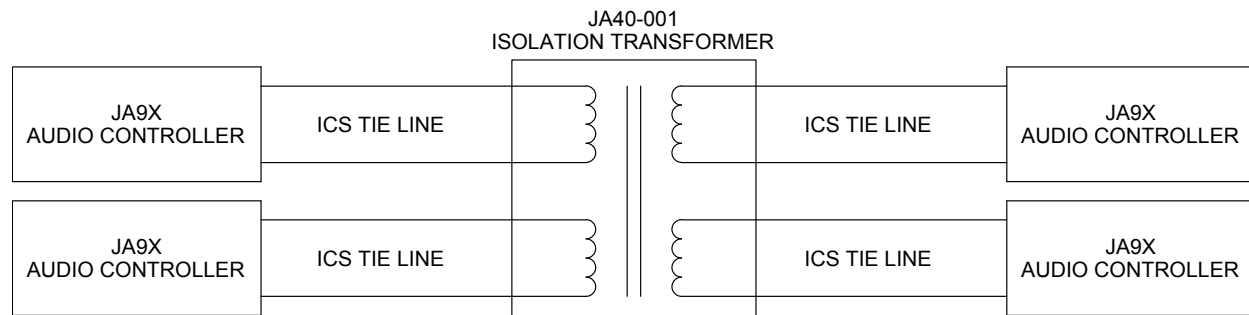

# JA40-001 Specifications

## Installation

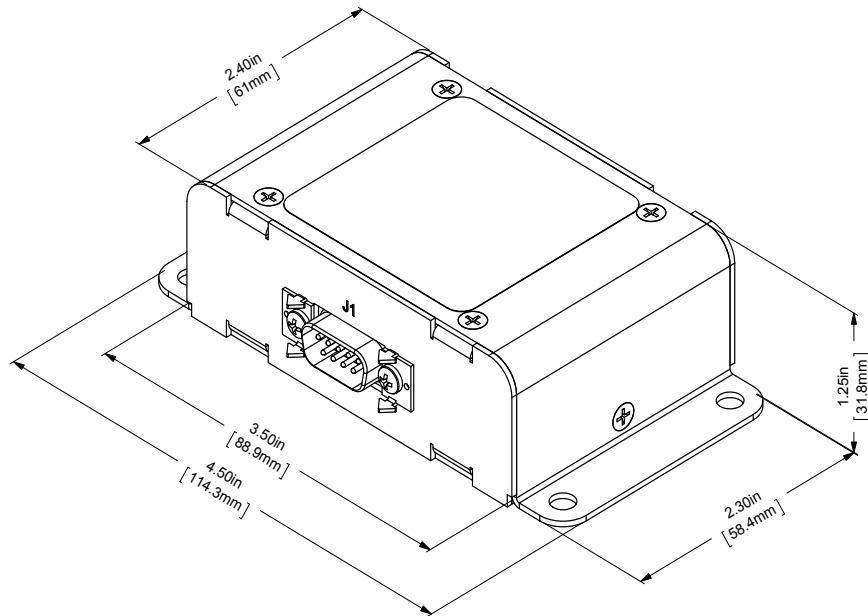

Weight: 0.44 lb. [0.20 Kg] Max.

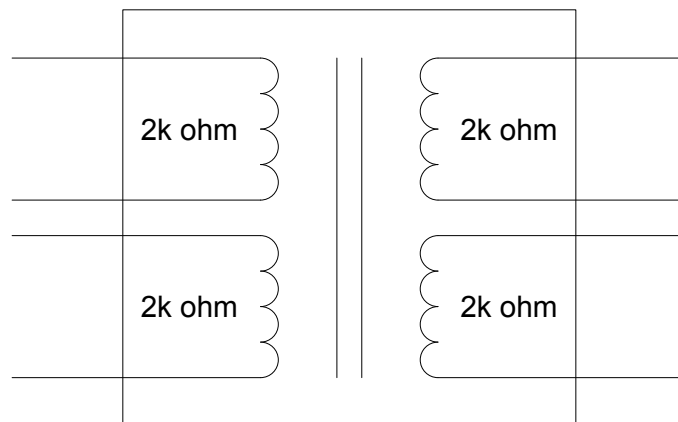

## Environment and Performance

Operating Temperature	-40 C to +70 C
Survival Temperature	-55 C to +85 C
Altitude	50,000 ft. max
Humidity	95%, 48 hrs
Shock	20g (any axis)
TSO Compliance	CAN TSO-C139 (Pending)
Installation Kit	INST-JA40



**JUPITER AVIONICS**  
CORPORATION

**JA40-001**

**ICS Tie Line Isolation Transformer**

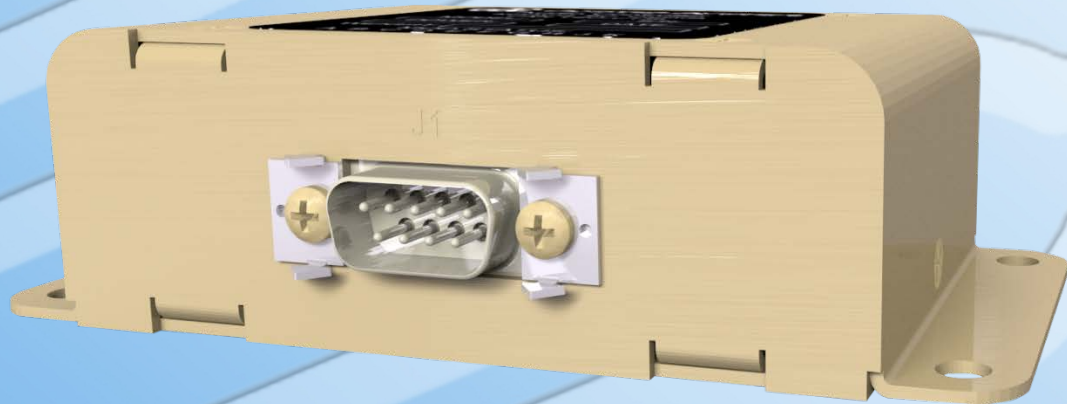

**Installation Manual**

**Rev. B**

**Jupiter Avionics Corporation**

**1959 Kirschner Road**

**Kelowna BC**

**Canada V1Y 4N7**

**Tel: +1 778 478 2232**

**Toll-Free: 1 855 478 2232**

**[www.jupiteravionics.com](http://www.jupiteravionics.com)**





## Table of Contents

<b>SECTION 1 - DESCRIPTION</b> .....	<b>1</b>
1.1 System Overview .....	1
1.2 Features Overview.....	1
1.3 Inputs and Outputs .....	1
1.3.1 Bi-directional Ports.....	1
1.4 Specifications.....	1
1.4.1 Electrical Specifications .....	1
1.4.2 Mechanical Specifications .....	2
1.4.H Flammability of Materials .....	2
<b>SECTION 2 – INSTALLATION</b> .....	<b>1</b>
2.1 Introduction .....	1
2.2 Continued Airworthiness.....	1
2.3 Unpacking and Inspecting Equipment.....	1
2.3.1 Warranty .....	1
2.4 Installation Procedures .....	1
2.4.1 Cabling and Wiring .....	1
2.4.2 Mechanical Installation .....	2
2.4.3 Post Installation Checks .....	2
2.5 System Operation .....	2
2.6 Installation Kit .....	2
2.6.1 Recommended Crimp tools .....	2
2.7 Installation Drawings.....	2
<b>Appendix A - Installation Drawings</b> .....	<b>A1</b>
A1 Introduction .....	A1
A2 Installation Drawings.....	A1
<b>Appendix B - <del>Flight</del> Documents</b> .....	<b>B1</b>
B1 Airworthiness <del>Documents</del> .....	B2
B2 Instructions for Continued Airworthiness .....	B2



## JA40-001 ICS Tie Line Isolation Transformer

### SECTION 1 - DESCRIPTION

#### 1.1 System Overview

The JA40 Intercom Tie Line Isolation Transformer allows four bi-directional intercom tie lines to be coupled and provides galvanic isolation. This prevents ground loops and common impedance problems in multi-box intercom installations.

#### 1.2 Features Overview

The JA40 features a fully balanced interconnect with shielded transformers and an aluminum enclosure.

#### 1.3 Inputs and Outputs

Refer to the JA40-001 [connector map](#) for the mating connector designators and pin assignments for the input and output signals.

##### 1.3.1 Bi-directional Ports

###### ICS Tie-line

The JA40 connector has eight contacts to provide four ICS TIE LINE HI / LO bidirectional audio signals.

#### 1.4 Specifications

##### 1.4.1 Electrical Specifications

The JA40 does not require aircraft electrical power.

###### 1.4.1.1 Audio Performance

###### Rated Input Level

Audio rated input level 1.20 Vrms ±10 %

###### Rated Output Power

Audio rated output power 1.20 Vrms ±20 %

###### Audio Frequency Response

Audio frequency response ≤ 3 dB from 300 to 6000 Hz

###### Distortion Characteristics

Audio output distortion at rated power ≤ 10 %  
Audio output distortion at 10% of rated power ≤ 3 %

###### Connected Load

ICS TIE load (4 ea.) 2000 Ω ±10 %



<u>Input to output Crosstalk and Bleed-through Level</u>	N/A
<u>Input to Input Crosstalk Level</u>	N/A
<u>Audio Noise Level without Signal</u>	
Noise level below the rated output	≥ 60 dB
<u>1.4.1.2 Audio Performance, Other</u>	
ICS TIE LINE HI/LO circuitry type	Transformer coupled
<u>1.4.2 Mechanical Specifications</u>	
Height	1.27 in [32.3 mm] maximum
Depth	2.61 in [66.3 mm] maximum
Width	4.52 in [114.8 mm] maximum
Weight	0.37 lbs [0.167 kg] maximum
Material	brushed aluminum with conversion coating
Connector J1	One 9-pin D-Sub male V5 locking
Mounting	4 x 10-32 fasteners
Bonding	≤ 2.5 mΩ
Installation kit part number	INST-JA40

#### 1.4.H Flammability of Materials

The JA40-001 complies with the requirements of RTCA/DO-160G Sec 26.3.3 "Flammability", through equivalent flammability testing of materials and the Small Parts Exemption.

## JA40-001 ICS Tie Line Isolation Transformer

### SECTION 2 – INSTALLATION

#### 2.1 Introduction

This section contains unpacking and inspection procedures, installation information, and post-installation checks.

#### 2.2 Continued Airworthiness

Maintenance of the JA40-001 is on condition only. Scheduled inspection and/or periodic maintenance of this unit is not required.

#### 2.3 Unpacking and Inspecting Equipment

Unpack the equipment carefully. Check for shipping damage and report any problems to the relevant carrier. Confirm that the Authorized Release Certificate or Certificate of Conformance is included. Complete the on-line warranty card from the Jupiter Avionics Corporation (JAC) website – [www.jupiteravionics.com/warranty](http://www.jupiteravionics.com/warranty)

##### 2.3.1 Warranty

All products manufactured by JAC are warranted to be free of defects in workmanship or performance for 2 years from the date of installation by an approved JAC dealer or agency. This warranty covers the cost of all materials and labour to repair or replace the unit, but does not include the cost of transporting the defective unit to and from JAC or its designated warranty repair centre, or of removing and replacing the defective unit in the aircraft. This warranty does not cover failures due to abuse, misuse, accident, or unauthorized alteration or repairs.

THIS WARRANTY IS VOID IF THE PRODUCT IS NOT INSTALLED BY AN AUTHORIZED JAC DEALER. If the on-line warranty card is not completed, the product will be warranted from the date of manufacture.

Contact JAC for return authorization, and for any questions regarding this warranty and how it applies to your unit(s). JAC is the final arbiter concerning warranty issues.

#### 2.4 Installation Procedures



---

**CAUTION: The power input circuitry of the unit may be damaged if the installation does not conform to the wiring instructions in this manual.**

---

##### 2.4.1 Cabling and Wiring

All wire shall be selected in accordance with the original aircraft manufacturer's maintenance instructions, or AC43.13-1B Change 1, Paragraphs 11-76 through 11-78. Unshielded wire types shall qualify to MIL-W-22759 as specified in AC43.13-1B Change 1, Paragraphs 11-85, 11-86, and listed in Table 11-11. For shielded wire applications, use Tefzel MIL-C-27500 shielded wire with tag ring or equivalent (for shield terminations) to make the most compact and easily terminated interconnect. Follow the Connector Map in Appendix A of this manual.

Allow 3" from the end of the shielded wiring to the shield termination to allow the connector hood to be easily installed. Refer to the Interconnect drawing in Appendix A of this manual for shield termination details. Note that this unit has a 'clamshell' hood that is installed after the wiring is complete.

Maintain wire segregation and route wiring in accordance with the original aircraft manufacturer's maintenance instructions.

Unless otherwise noted, all wiring shall be a minimum of 24 AWG, except ground lines, which shall be a minimum of 20 AWG. Refer to the Interconnect drawing for additional specifications. Check that the ground connection is clean and well secured, and that it shares no path with any electrically noisy aircraft accessories such as blowers, turn-and-bank instruments, or similar loads.





## 2.4.2 Mechanical Installation

The JA40-001 can be mounted in any attitude and location with adequate space and sufficient clearance for the connector and wiring harness. It requires no direct cooling.

## 2.4.3 Post Installation Checks

### 2.4.3.1 Voltage/Resistance checks.

Do not attach this unit until the following conditions are met:

- a) Check P1 pin **5** for continuity to ground (less than 0.5 Ω).
- b) Check all pins for shorts to ground or adjacent pins.

### 2.4.3.2 Power on Checks.

Power up the aircraft's systems and confirm normal operation of all functions of the JA40.

When all performance checks are satisfied, complete the necessary regulatory documentation before releasing the aircraft for service. Refer to [Appendix B](#).

## 2.5 System Operation

The JA40-001 combines up to four bi-directional ICS TIE Line audio signals from four intercoms.

## 2.6 Installation Kit

The kit required to install this unit is not included with the unit.

The installation kit (Part # INST-JA40) consists of the following:

<u>Quantity</u>	<u>Description</u>	<u>JAC Part #</u>
1	9 Socket, D-Submin - Crimp Socket Connector Assy	CON-3420-0009
1	0.375" Inside Diameter, Hardware - Tag Ring	CON-5500-0375
1	JA40-001 Assembly Notes, Installation Kit	DOC-INST-JA40
1	3/4" Inside Diameter, Heat Shrink Tube	WIR-HTSK-0750

### 2.6.1 Recommended Crimp tools

<u>Connector Type</u>	<u>Hand crimp tool</u>	<u>Positioner</u>	<u>Insertion/extraction tool</u>
Positronic	9507	9502-3	M81969/1-04
Positronic	AFM8 (Daniels)	M22520/2.08 KB-1	

## 2.7 Installation Drawings

The drawings and documents required for Installation can be found in [Appendix A](#) of this manual.



# Installation Manual

## Appendix A - Installation Drawings

### A1 Introduction

The drawings necessary for installation and troubleshooting of the JA40-001 ICS Tie Line Isolation Transformer are in this Appendix, as listed below.

### A2 Installation Drawings



DOCUMENT	Rev
<a href="#">JA40-001 Connector Map</a>	A
<a href="#">JA40-001 Interconnect</a>	A
<a href="#">JA40-001 Mechanical Installation</a>	A

**P1**

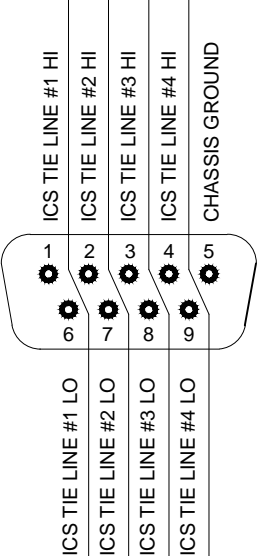
9 PIN FEMALE DMIN  
MATING CONNECTOR



VIEW IS FROM REAR OF MATING CONNECTOR

PREPARED	TAT	 <b>JUPITER AVIONICS</b> CORPORATION		
CHECKED				
APPROVED		ICS Tie Line Isolation Transformer		
CONFIDENTIAL & PROPRIETARY TO JUPITER AVIONICS CORP.		NCAGE CODE L00N3	PART NO. JA40-001	DOC NO. JA40-001 Connector Map Rev A.DWG

JA40-001 INTERCONNECT WIRING NOTES

NOTES

1. ALL WIRE SIZE SHOULD BE 24 AWG MIN UNLESS OTHERWISE SPECIFIED. UNSHIELDED WIRE SHOULD BE SELECTED PER FAA AC43.13-1B CHANGE 1 PARA 11-76 TO 11-78. WIRE TYPES SHOULD BE IN ACCORDANCE WITH MIL-W-22759 AS DESCRIBED IN FAA AC43.13-1B CHANGE 1 PARA 11-85 AND 11-86 AND LISTED IN TABLE 11-11 OR 11-12. ALL SHIELDED CABLE SHOULD BE IN ACCORDANCE WITH MIL-DTL-27500 (REVISION H OR LATER).

2. CONNECTION TO AIRFRAME GROUND SHOULD BE MADE WITH 20 AWG WIRE. LENGTH NOT TO EXCEED 3 FT (0.91 M).

3. CABLE SHIELDS AT THE JA40-001 CONNECTOR PINS SHOULD BE TERMINATED TO AIRFRAME GROUND USING A TAG RING P/N: MS27741-5 OR EQUIVALENT.

PREPARED	TAT	 <b>JUPITER AVIONICS CORPORATION</b>		
CHECKED				
APPROVED		NCAGE CODE L00N3	PART NO. JA40-001	SHEET 1/2
CONFIDENTIAL & PROPRIETARY TO JUPITER AVIONICS CORP.		DOC NO. JA40-001 Interconnect Rev A.DWG		

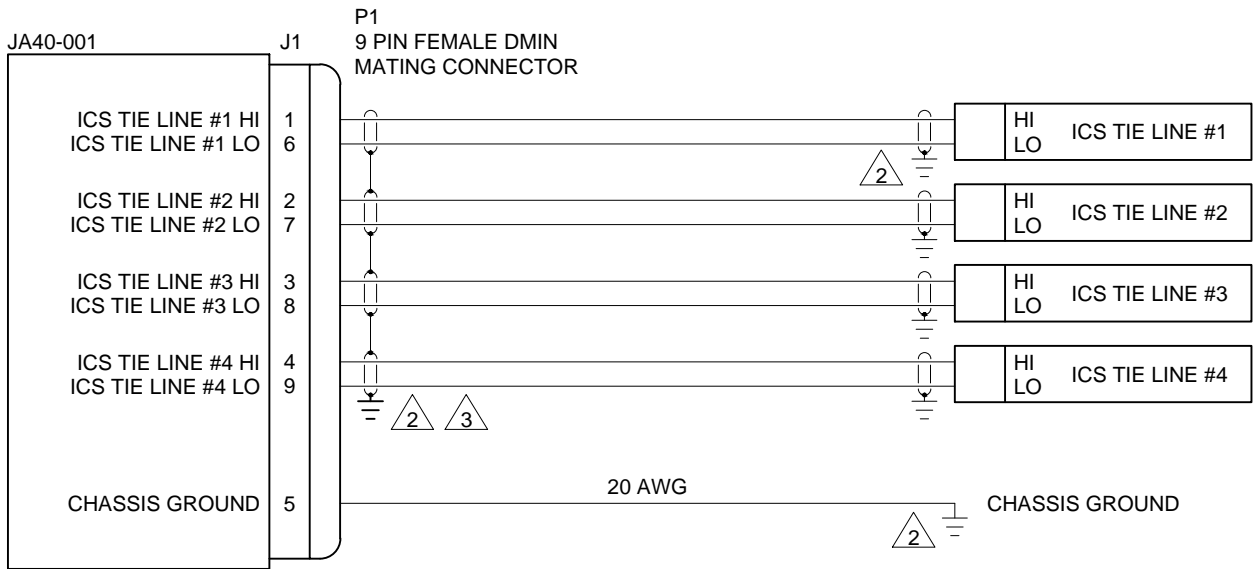

PREPARED	TAT			
CHECKED				
APPROVED		NCAGE CODE L00N3	PART NO. JA40-001	SHEET 2/2
CONFIDENTIAL & PROPRIETARY TO JUPITER AVIONICS CORP.		DOC NO. JA40-001 Interconnect Rev A.DWG		

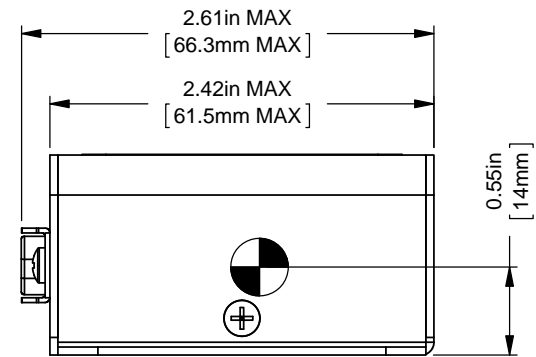
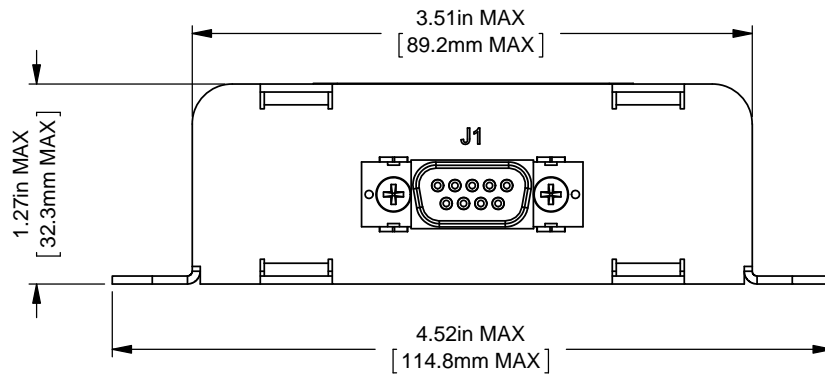
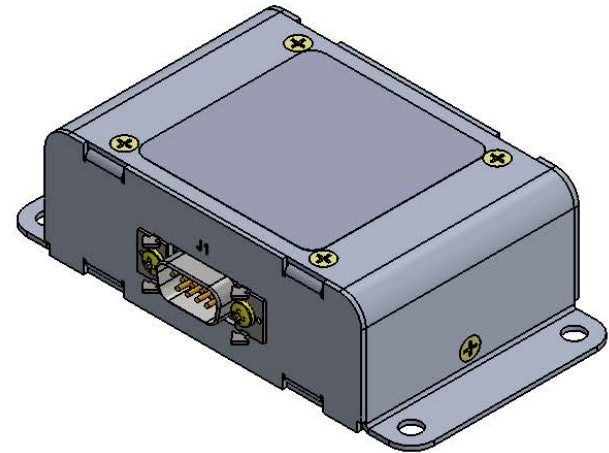
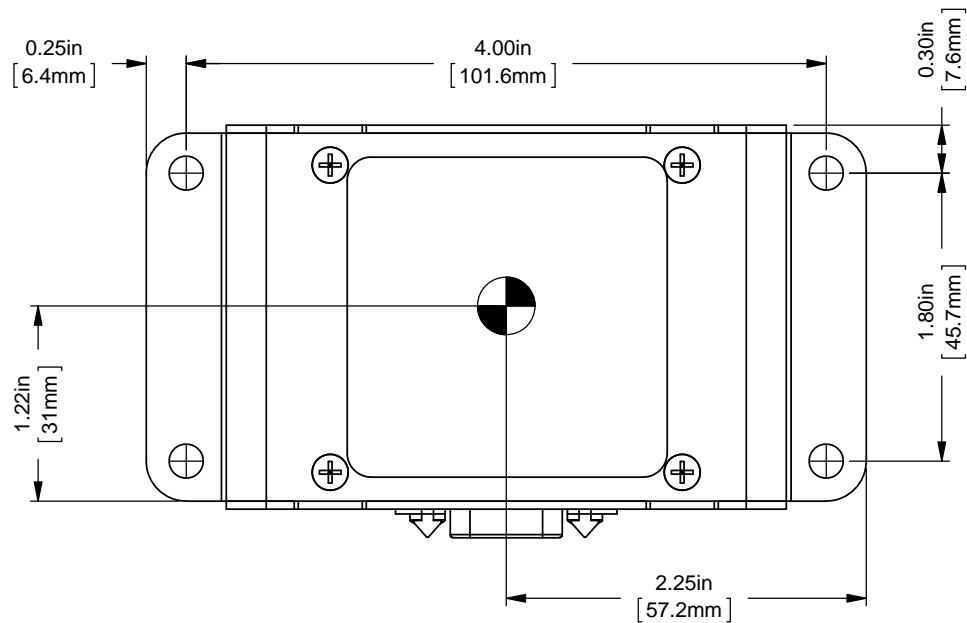

 CENTER OF GRAVITY  
±0.03in [0.8mm]

WEIGHT: 0.37 lbs [0.17 Kg] MAX.

UNLESS OTHERWISE SPECIFIED  
DIMENSIONS ARE IN INCHES  
ANGLES ARE IN DEGREES  
TOLERANCES:  
1 DEC PLACE: ± 0.1  
2 DEC PLACE: ± 0.01  
3 DEC PLACE: ± 0.005  
ANGLES: ± 0.5 DEG

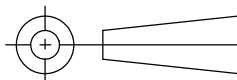

MATERIAL: N/A  
FINISH: N/A

PREPARED

TAT

CHECKED



APPROVED



CONFIDENTIAL & PROPRIETARY  
TO JUPITER AVIONICS CORP.  
DRAWING NOT TO SCALE



**JUPITER AVIONICS**  
CORPORATION

TITLE

ICS Tie Line Isolation Transformer - 4 Channel

NCAGE CODE  
L00N3

PART NO.  
JA40-001

SHEET  
1/1

DOC. NO.  
JA40-001 Mechanical Installation Rev A.SLDDRW



# **Installation Manual**

## **Appendix B - Configuration Documents**



## **B1      Airworthiness**

Airworthiness approval of the JA40-001 may require completion of a TCCA Major Modification Report per CAR STD (AWM) 571 Appendix L, or a FAA Form 337. The sample wording for a description of the work is provided to assist the Installing Agency in preparing Instructions for Continued Airworthiness (ICA) when replacing an existing Isolation Transformer with a Jupiter Avionics JA40-001 ICS Tie Line Isolation Transformer. This sample may be modified appropriately for new installations. It is the installer's responsibility to determine the applicability of the method used. Installations performed outside Canada must follow the applicable aviation authority's regulations.

### **Sample Wording:**

Removed the existing [model] Isolation Transformer and replaced with a Jupiter Avionics JA40-001 ICS Tie Line Isolation Transformer in [aircraft location].

Installed in accordance with the JA40-001 Installation Manual, Revision [ ], and AC 43.13-2, Chapters 2, and 3.

The JA40-001 interfaces with existing aircraft systems per the Installation Manual instructions.

The JA40-001 Installation Manual provides detailed installation instructions and wiring diagrams (Section 2, and Appendices A and B).

The JA40-001 does not require electrical power.

Aircraft equipment list, weights and balance amended. Compass compensation checked and found to conform to applicable regulations.

## **B2      Instructions for Continued Airworthiness**

Maintenance of the JA40-001 ICS Tie Line Isolation Transformer is "on condition" only. Refer to the JA40-001 Maintenance Manual. Periodic maintenance of the JA40-001 is not required.

The following sample Instructions for Continued Airworthiness (ICA) provides assistance in preparing ICA for the Jupiter Avionics JA40-001 unit installation as part of a Type Certificate (TC) or Supplemental Type Certificate (STC) project to comply with CAR STD (AWM) 523/527/525/529.1529 or FAR 23/25/27/29.1529 "Instructions for Continued Airworthiness".

Items that may vary by aircraft make and model are shown in brackets ("[ ]") and should be filled in as appropriate. Some of the checklist items do not apply, in which case they should be marked "N/A" (Not Applicable).

## **Instructions for Continued Airworthiness, Jupiter Avionics JA40-001 ICS Tie Line Isolation Transformer in an [Aircraft Make and Model]**

### **1. Introduction**

[Aircraft that has been altered: Registration number, Make, Model and Serial Number]

**Content, Scope, Purpose and Arrangement:** This document identifies the Instructions for Continued Airworthiness for a Jupiter Avionics JA40-001 installed in an [aircraft make and model].

**Applicability:** Applies to a Jupiter Avionics JA40-001 installed in an [aircraft make and model].

**Definitions/Abbreviations:** None, N/A.

**Precautions:** None, N/A.

**Units of Measurement:** None, N/A.

**Referenced Publications:** JA40-001 Installation Manual  
JA40-001 Maintenance Manual  
STC/TC # [applicable STC/TC number for the specific aircraft installation]

**Distribution:** This document should be a permanent aircraft record.





## **2. Description of the System/Alteration**

Jupiter Avionics JA40-001 ICS Tie Line Isolation Transformer with interface to the intercom system and [include other equipment/systems as appropriate]. Refer to Appendix A of this manual for interconnect information. Refer to aircraft manufacturer approved interconnect for actual installation.

## **3. Control, Operation Information**

N/A

## **4. Servicing Information**

N/A

## **5. Maintenance Instructions**

Maintenance of the JA40-001 is 'on condition' only. Periodic maintenance is not required. Refer to the JA40-001 Maintenance Manual.

## **6. Troubleshooting Information**

Refer to the JA40-001 Maintenance Manual.

## **7. Removal and Replacement Information**

Refer to Section 2 of this manual - the JA40-001 Installation Manual. If the unit is removed and reinstalled, a functional check of the equipment should be conducted.

## **8. Diagrams**

Refer to Appendix A of this manual - the JA40-001 Installation Manual - for installation drawings and interconnect examples.

## **9. Special Inspection Requirements**

N/A

## **10. Application of Protective Treatments**

N/A

## **11. Data: Relative to Structural Fasteners**

JA40-001 and appropriate mounting hardware installation, removal and replacement should be in accordance with applicable provisions of AC 43.13-1B and AC 43.13-2A.

## **12. Special Tools**

N/A

## **13. This Section is for Commuter Category Aircraft Only**

A. **Electrical loads:** Refer to Section 1 of the JA40-001 Installation Manual.

B. **Methods of balancing flight controls:** N/A.

C. **Identification of primary and secondary structures:** N/A.

D. **Special repair methods applicable to the airplane:** N/A.

## **14. Overhaul Period**

No additional overhaul time limitations.

## **15. Airworthiness Limitation Section**

N/A