

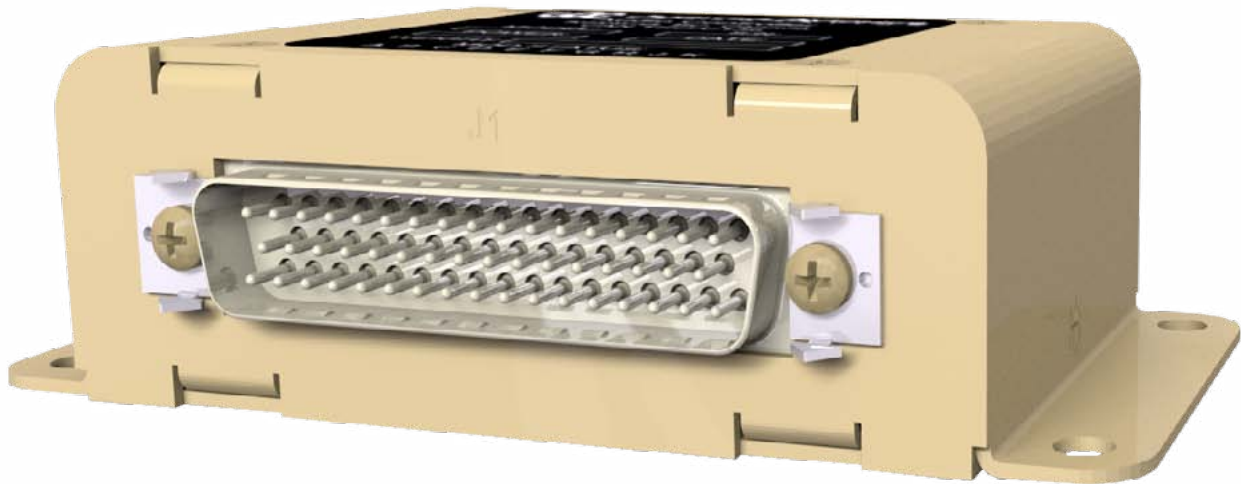

JRS12-001 Data Transfer Switch JRS14-001 Data Transfer Switch

Data Sheet



Description

The JRS12-001 / JRS14-001 Transfer Switches are compact, high density, bulkhead mounted remote switching units designed to handle the switching requirements of navaid, audio or other interface applications. Both the JRS12 and JRS14 allow large numbers of data or audio lines to be transferred with a single control line. All relay switches have a contact rating of 1 amp / 30 vdc.

The JRS12 includes circuitry for flag load resistors and flag bias generators.

The JRS14 includes 2 extra poles of switching contacts and 1 flag bias generator.



JRS12/JRS14 Specifications

Installation

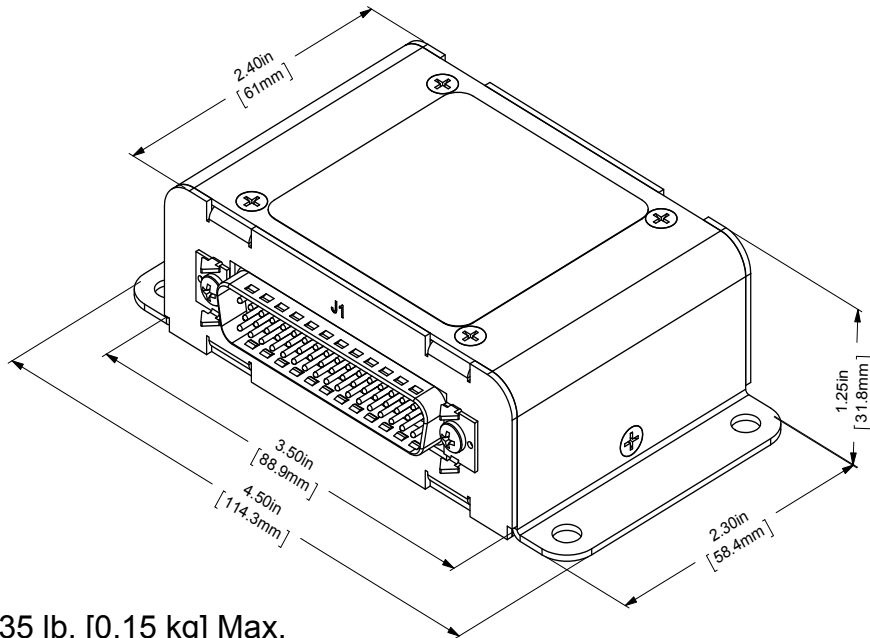

Weight: 0.35 lb. [0.15 kg] Max.

JRS12 Additional Circuitry

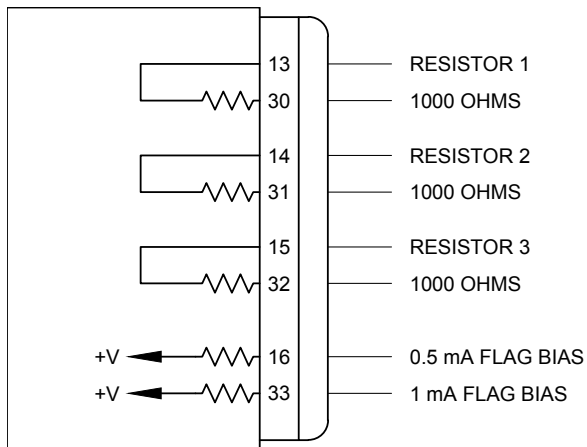

JRS14 Additional Circuitry

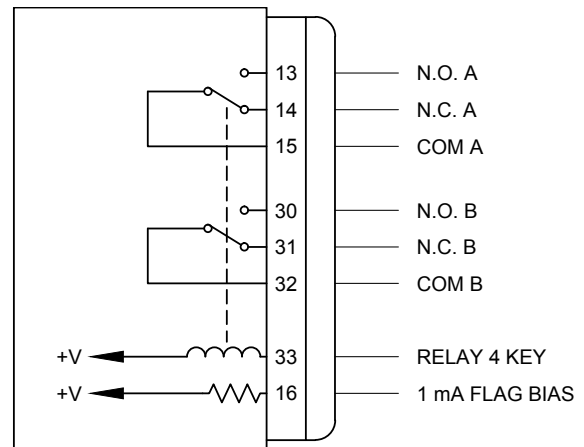

Environment and Performance

| | |
|-----------------------|-------------------------|
| Operating Temperature | -40 C to +70 C |
| Survival Temperature | -55 C to +85 C |
| Altitude | 50,000 ft. max |
| Humidity | 95%, 48 hrs |
| Shock | 20g (any axis) |
| TSO Compliance | CAN TSO-C139 (Pending) |
| Installation Kit | INST-JRS12 / INST-JRS14 |



JUPITER AVIONICS
C O R P O R A T I O N

JRS14-001 Relay Switch

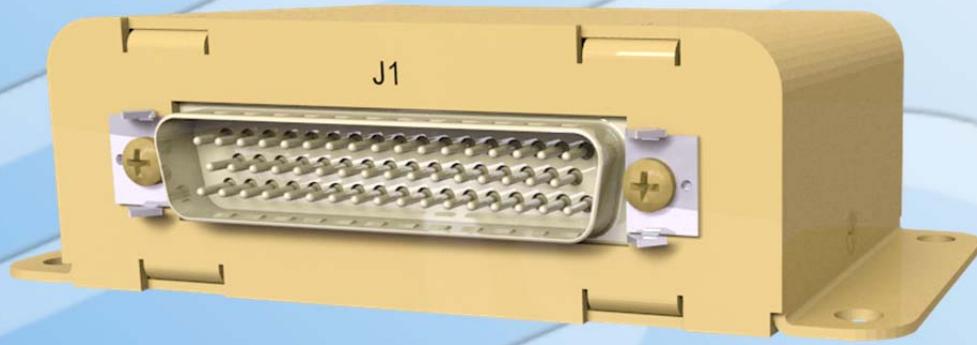

Installation and Operating Manual

Rev. C

Jupiter Avionics Corporation
1959 Kirschner Road
Kelowna BC
Canada V1Y 4N7
Tel: +1 778 478 2232
Toll-Free: 1 855 478 2232
www.jupiteravionics.com



Copyright 2013 Jupiter Avionics Corp.

All rights reserved

Jupiter Avionics Corporation (JAC) permits a single copy of this manual to be printed or downloaded for the express use of an installing agency. Any such electronic or printed copy of this manual must contain the complete text of this copyright notice. Any unauthorized commercial distribution of this manual is strictly prohibited. Except as described above, no part of this manual may be reproduced, copied, transmitted, disseminated, downloaded, or stored in any storage medium for any purpose without the express prior written consent of JAC.

IMPORTANT:

Information in this document is subject to change without notice.
 To confirm the current revision status of this manual, visit the JAC website:
www.jupiteravionics.com

| Record of Revisions | | | |
|----------------------------|-----------------|------------------------------------------------|------------|
| Revision | Rev Date | Description | ECR |
| A | Feb 2013 | Initial Release. Serial number 1001 and higher | 1019, 1021 |
| B | Feb 2014 | Modified Certification Statement | 2590 |
| C | Oct 2014 | JRS14-001 only. Modified Voltage Requirements | 3032 |
| | | | |
| | | | |
| | | | |
| | | | |
| | | | |
| | | | |
| | | | |
| | | | |
| | | | |
| | | | |
| | | | |
| | | | |
| | | | |
| | | | |
| | | | |
| | | | |
| | | | |
| | | | |
| | | | |
| | | | |
| | | | |
| | | | |
| | | | |
| | | | |
| | | | |
| | | | |

| | | |
|----------------------|----------|-----------|
| Prepared: MPB | Checked: | Approved: |
|----------------------|----------|-----------|



Table of Contents

| | |
|-------------------------------------------------|-----------|
| SECTION 1 - DESCRIPTION | 1 |
| 1.1 System Overview | 1 |
| 1.2 Features Overview | 1 |
| 1.2.1 Functionality | 1 |
| 1.2.2 Emergency procedures | 1 |
| 1.3 Inputs and Outputs | 2 |
| 1.3.1 Inputs | 2 |
| 1.3.1 Outputs | 2 |
| 1.4 Specifications | 2 |
| 1.4.1 Electrical Specifications | 2 |
| 1.4.2 Physical Specifications | 3 |
| SECTION 2 – INSTALLATION | 4 |
| 2.1 Introduction | 4 |
| 2.2 Continued Airworthiness | 4 |
| 2.3 Unpacking and Inspecting Equipment | 4 |
| 2.3.1 Warranty | 4 |
| 2.4 Installation Procedures | 4 |
| 2.4.1 Cabling and Wiring | 4 |
| 2.4.2 Mechanical Installation | 5 |
| 2.4.3 Post Installation Checks | 5 |
| 2.5 Adjustments | 6 |
| 2.6 Installation Kit | 6 |
| 2.6.1 Recommended Crimp tools | 6 |
| 2.7 Installation Drawings | 6 |
| SECTION 3 – OPERATION | 7 |
| 3.1 Introduction | 7 |
| Appendix A - Installation Drawings | A1 |
| A1 Introduction | A1 |
| A2 Installation Drawings | A1 |

JRS14-001 Relay Switch

SECTION 1 - DESCRIPTION

1.1 System Overview

The JRS14-001 Relay Switch is a compact, high-density, bulkhead-mounted remote switching unit that provides fourteen “C style” contacts to handle the switching requirements of navaid, audio, and other interface applications. It allows up to 14 data or audio lines to be transferred with a single control line.

1.2 Features Overview

The JRS14-001 features industry standard interconnects to allow easy field upgrades.

The JRS14-001 provides switching for 14 contacts of information, organized as three groups of two 2PDT relays and one group of one 2PDT, each with an individual key line. Each group can be used independently, or can be picked as one group (14 contact sets) by applying the required logic level to the appropriate ALL GROUP KEY line.

These relay switches can be used for applications from dry circuit to 0.5 A switching, but are limited to a maximum of 30 Vdc. They can be operated from +18 to +33 Vdc without changing the interconnect.

All interconnect and relay contacts are gold plated. Relays are sealed, high vibration rated (50g shock), dry nitrogen filled units.

All relay switches have a contact rating of 1 amp/30 Vdc

1.2.1 Functionality

The JRS14-001 provides remote switching of navigation or audio signals to allow system expansion or interconnection. Once installed, it operates independently to provide the required switching functions without any operator action.

1.2.2 Emergency procedures

The JRS14-001 does not affect the emergency procedures of the aircraft. If the unit is used to switch navigation signals, flight personnel should be made aware of its function.



1.3 Inputs and Outputs

Refer to the JRS14-001 connector map for the mating connector designators and pin assignments for the input and output signals.

1.3.1 Inputs

Refer to the JRS14-001 connector map drawing for the mating connector designators and contact assignments for the input signals.

| Input | Type | Quantity |
|------------------------------|---------------|-----------------|
| GROUP KEY | active low | 4 |
| ALL GROUP KEY | active low | 1 |
| POWER INPUT and POWER GROUND | power | 2 |
| Common signal inputs | relay contact | 14 |

1.3.1 Outputs

Refer to the JRS14-001 connector map drawing for the mating connector designator and contact assignments for the output signals.

| Output Type | Type | Quantity |
|--------------------------------|----------------|-----------------|
| Normally open signal outputs | relay contact | 14 |
| Normally closed signal outputs | relay contact | 14 |
| Bias voltage output contacts | voltage source | 1 |

1.4 Specifications

1.4.1 Electrical Specifications

Power Input

| | |
|-------------------|----------------------|
| Nominal voltage | 28 Vdc |
| Maximum voltage | 30.3 Vdc |
| Minimum voltage | 22.0 Vdc |
| Emergency voltage | 18.0 Vdc |
| Input current | ≤ 0.2 A max @ 28 Vdc |

1.4.1.1 Audio Performance

Rated Input Level

| | |
|-------------------------|-----------------------------|
| Audio rated input level | 7.75 Vrms ± 10% 1.0Arms max |
|-------------------------|-----------------------------|

Rated Output Level

| | |
|--------------------------|------------------------------|
| Audio rated output level | 7.75 Vrms ± 10% 1.0 Arms max |
|--------------------------|------------------------------|

Audio Frequency Response

| | |
|---------------------------------------|---------------------------|
| Audio output audio frequency response | ≤ 3dB from 300 to 6000 Hz |
|---------------------------------------|---------------------------|

Distortion Characteristics

| | |
|-----------------------------------------------|-------|
| Audio output distortion at rated power | ≤ 10% |
| Audio output distortion at 10% of rated power | ≤ 3% |



Input to output Crosstalk and Bleed-through Level

Input to output Crosstalk ≤ 55 dB

Input to Input Crosstalk Level

Input to Input crosstalk ≤ 60 dB

Audio Noise Level without Signal

Noise level below the rated output ≥ 60 dB

1.4.1.2 Control Signal Performance

Discrete Signals

Active low control input shall be active when the signal is $\leq +3$ Vdc

Active low control input shall be inactive when the signals is $\geq +10$ Vdc

Active low control input signals, when active, shall source ≤ 20 mA

Output signals, when active, shall sink ≤ 1 A

1.4.2 Physical Specifications

| | |
|------------------------------|------------------------------------------|
| Height (maximum) | 1.25" [31.8 mm] |
| Overall depth (maximum) | 2.30" [58.4 mm] |
| Width (maximum) | 4.50" [114.3 mm] |
| Weight (maximum) | 0.35 lb [0.15 g] |
| Enclosure material | brushed aluminum with conversion coating |
| Connectors | One 50 pin D-Sub male, V5 locking |
| Mounting | 4 ea 10-32 screws |
| Bonding | ≤ 2.5 m Ω |
| Installation kit part number | INST-JRS1x |

JRS14-001 Relay Switch

SECTION 2 – INSTALLATION

2.1 Introduction

This section contains unpacking and inspection procedures, installation information, and post-installation checks.

2.2 Continued Airworthiness

Maintenance of the JRS14-001 is on condition only. Scheduled inspection and/or periodic maintenance of this unit is not required.

2.3 Unpacking and Inspecting Equipment

Unpack the equipment carefully. Check for any obvious shipping damage and report any problems to the relevant carrier. Confirm that the Certificate of conformity or release certification is included. Complete the on-line warranty card from the Jupiter Avionics Corporation (JAC) website – www.jupiteravionics.com/warranty.

2.3.1 Warranty

All products manufactured by JAC are warranted to be free of defects in workmanship or performance for 2 years from the date of installation by an approved JAC dealer or agency. This warranty covers the cost of all materials and labour to repair or replace the unit, but does not include the cost of transporting the defective unit to and from JAC or its designated warranty repair centre, or of removing and replacing the defective unit in the aircraft. This warranty does not cover failures due to abuse, misuse, accident, or unauthorized alteration or repairs.

THIS WARRANTY IS VOID IF THE PRODUCT IS NOT INSTALLED BY AN AUTHORIZED JAC DEALER. If the on-line warranty card is not completed, the product will be warranted from the date of manufacture.

Contact JAC for return authorization, and for any questions regarding this warranty and how it applies to your unit(s). JAC is the final arbiter concerning warranty issues.

2.4 Installation Procedures



CAUTION: The power input circuitry of the unit may be damaged if the installation does not conform to the wiring instructions and circuit breaker rating in this manual.

2.4.1 Cabling and Wiring

All wire shall be selected in accordance with the original aircraft manufacturer's maintenance instructions, or AC43.13-1B Change 1, Paragraphs 11-76 through 11-78. Unshielded wire types shall qualify to MIL-W-22759 as specified in AC43.13-1B Change 1, Paragraphs 11-85, 11-86, and listed in Table 11-11. For shielded wire applications, use Tefzel MIL-C-27500 shielded wire with solder sleeves (for shield terminations) to make the most compact and easily terminated interconnect. Follow the Connector Map in Appendix A of this manual.

Allow 3" from the end of the shielded wiring to the shield termination to allow the connector hood to be easily installed. Refer to the Interconnect drawing in Appendix A of this manual for shield termination details. Note that this unit has a 'clamshell' hood that is installed after the wiring is complete.

Maintain wire segregation and route wiring in accordance with the original aircraft manufacturer's maintenance instructions.



Unless otherwise noted, all wiring shall be a minimum of 24 AWG, except power and ground lines, which shall be a minimum of 20 AWG. Refer to the Interconnect drawing for additional specifications. Check that the ground connection is clean and well secured, and that it shares no path with any electrically noisy aircraft accessories such as blowers, turn-and-bank instruments, or similar loads.

2.4.2 Mechanical Installation

The JRS14-001 can be mounted in any attitude and location with adequate space and sufficient clearance for the connector and wiring harness. It requires no direct cooling and no shock or vibration isolators are required.

2.4.2.1 Installation Considerations

If the JRS14-001 is to be used for NAV switching, for instance linking two sources to a common indicator, this must be clearly marked and placarded in the aircraft. External annunciation of any NAV source must comply with section 2.4.2.2 of this manual.

If the unit is to be used for GPS/MLF switching, it may be necessary to wire the unit to ensure that it returns to the VOR/ILS mode when the navigation receiver is tuned to an ILS frequency. Check local aviation regulations regarding this requirement.



NOTE: ILS reversion mode for NAV/GPS installations is not applicable in Canada.

2.4.2.2 External Switches and Lamps

All switches and/or annunciators must be selected to suit the application. A single pushbutton or toggle switch may be used to supply the ALL GROUP KEY line to allow all lines to be selected together. If a single switch or lamp assembly is used to replace the transfer switch and annunciators, it should be a lighted pushbutton switch (SPST/SPDT) with a positive action (i.e. push on/push off) with two legends to match the required NAV functions.

If the unit is to be used as audio key relays for boom mics etc., the unit can be triggered by in-line drop cords or similar ways that supply an input to the appropriate key line.

If it is to be used as a NAV selector, annunciator lights should be connected through one or more relay contacts to ensure correct indication of the actual relay contacts.

2.4.3 Post Installation Checks

2.4.3.1 Voltage/Resistance checks.

Do not attach this unit until the following conditions are met:

- a) Check P1 pin **17** for +28 Vdc relative to ground.
- b) Check P1 pin **34** for continuity to ground (less than 0.5 Ω).
- c) Check P1 pins **47 - 50** for continuity to ground (less than 0.5 Ω) when the relevant switch is closed.
- d) Check all pins for shorts to ground or adjacent pins.

2.4.3.2 System Operation

All operation is described with aircraft electrical power supplied, unless stated otherwise.

Individual Relay Key Operation

The individual relay common contacts connect to the Normally Open signal contacts when the GROUP (1 thru 4) KEY input is active.

The individual relay common contacts connect to the Normally Closed signal contacts when the GROUP (1 thru 4 and ALL) KEY input is not active.

All Relay Key Operation

The all relay common contacts connect to the Normally Open signal contacts when the ALL GROUP KEY input is active.



Bias Resistor Operation

The bias resistors provide an electrical current on a continuous basis

2.4.3.3 Power on Checks.

Power up the aircraft's systems and check that all switching functions transfer correctly with the appropriate relay action. If the internal flag bias is used for indicator interfacing, ensure that this function works correctly, and only in the selected or transferred position.

When all performance checks are satisfied, complete the necessary regulatory documentation before releasing the aircraft for service.

2.5 Adjustments

The JRS14-001 has no internal mechanical adjustments.

2.6 Installation Kit

The kit required to install this unit is not included with the unit.

The JRS14 requires one installation kit (Part # INST-JRS1x) which consists of the following:

| Quantity | Description | JAC Part # |
|-----------------|---------------------------------|-------------------|
| 1 | D-sub 50-pin Connector Assembly | CON-3420-0050 |
| 1 | TAG ring | CON-5500-0625 |
| 1 | Heatshrink Tubing | WIR-HTSK-1000 |

2.6.1 Recommended Crimp tools

| Connector Type | Hand crimp tool | Positioner | Insertion/extraction tool |
|-----------------------|------------------------|-------------------|----------------------------------|
| Positronic | 9507 | 9502-3 | M81969/1-04 |
| | | | |

2.7 Installation Drawings

The drawings and documents required for Installation can be found in [Appendix A](#) of this manual.

JRS14-001 Relay Switch

SECTION 3 – OPERATION

3.1 Introduction

The JRS14-001 has no operator controls.

If any switches or indicators have been installed to control or indicate the function of the unit, confirm their operation with the installing agency and ensure that the relevant information has been added to the flight manual where necessary.



Installation and Operation Manual

Appendix A - Installation Drawings

A1 Introduction

The drawings necessary for installation and troubleshooting of the JRS14-001 Relay Switch are in this Appendix, as listed below.

A2 Installation Drawings



| DOCUMENT | REV |
|---------------------------------------------------|-----|
| JRS14-001 Connector Map | B |
| JRS14-001 Interconnect | B |
| JRS14-001 Mechanical Installation | B |
| | |

P1

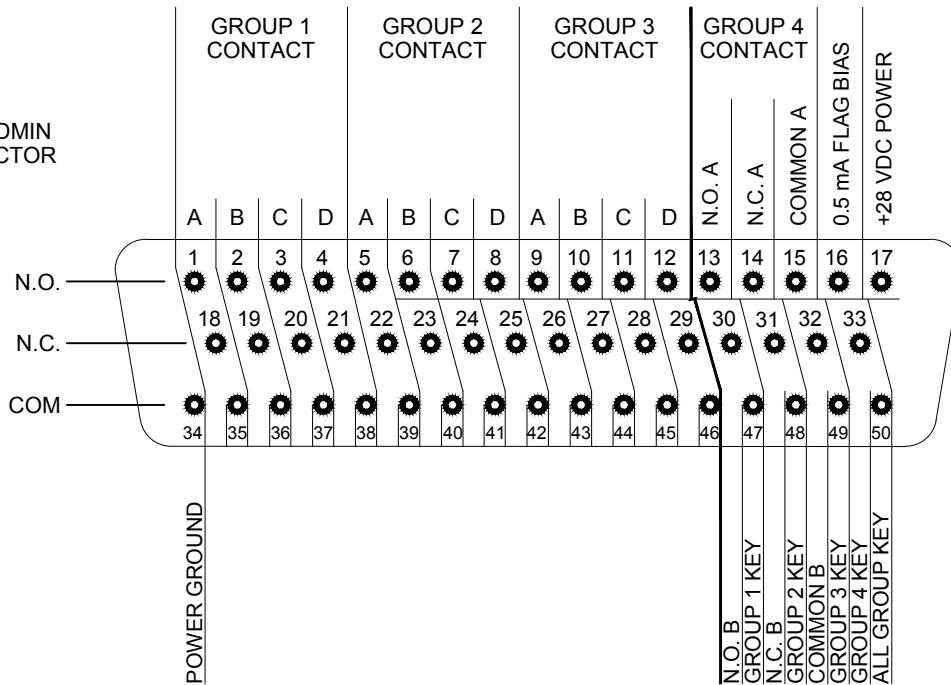
50 PIN FEMALE DMIN
MATING CONNECTOR





VIEW IS FROM REAR OF MATING CONNECTOR

| | | | | |
|---------------------------------------------------------|-------------------------------------------------------------------------------------|--------------------------------------------------------------------------------------|-----------------------|--|
| PREPARED | TAT |  | | |
| CHECKED |  | | | |
| APPROVED |  | NCAGE CODE L00N3 | PART NO. JRS14-001 | |
| CONFIDENTIAL & PROPRIETARY TO JUPITER AVIONICS CORP. | | DOC NO. JRS14-001 Connector Map Rev B.dwg | | |

JRS14-001 INTERCONNECT WIRING NOTES

NOTES

1. ALL WIRE SIZE SHOULD BE 24 AWG MIN UNLESS OTHERWISE SPECIFIED. UNSHIELDED WIRE SHOULD BE SELECTED PER FAA AC43.13-1B CHANGE 1 PARA 11-76 TO 11-78. WIRE TYPES SHOULD BE IN ACCORDANCE WITH MIL-W-22759 AS DESCRIBED IN FAA AC43.13-1B CHANGE 1 PARA 11-85 AND 11-86 AND LISTED IN TABLE 11-11 OR 11-12. ALL SHIELDED CABLE SHOULD BE IN ACCORDANCE WITH MIL-DTL-27500 (REVISION H OR LATER).
- △ 2 CONNECTION TO AIRFRAME GROUND SHOULD BE MADE WITH 20 AWG WIRE. LENGTH NOT TO EXCEED 3 FT (0.91 M).

| | | | | |
|------------------------------------------------------|-------------------------------------------------------------------------------------|--------------------------------------------------------------------------------------|-----------------------|-------|
| PREPARED | TAT |  | | |
| CHECKED |  | | | |
| APPROVED |  | Relay Switch 14 Contacts | | SHEET |
| CONFIDENTIAL & PROPRIETARY TO JUPITER AVIONICS CORP. | | NCAGE CODE L00N3 | PART NO. JRS14-001 | 1/2 |
| | | DOC NO. JRS14-001 Interconnect Rev B.dwg | | |

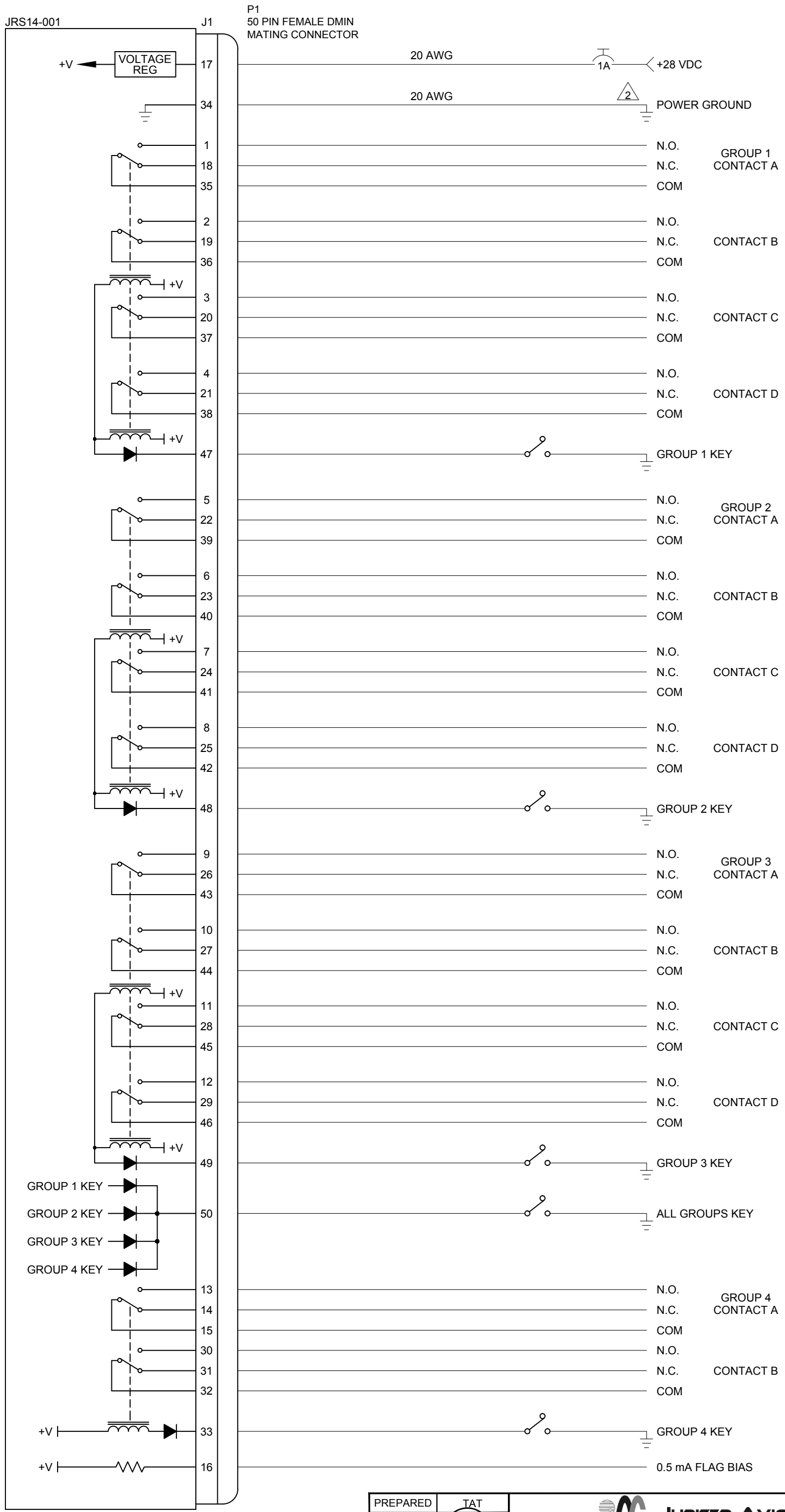

| | | | | |
|------------------------------------------------------|------------------------|---------------------------------------------------------------------------------------|-----------|-------|
| PREPARED | TAT |  | | |
| CHECKED | JAC 08-28-14 DS | | | TITLE |
| APPROVED | JAC 09-24-14 KDV | NCAGE CODE | PART NO. | SHEET |
| CONFIDENTIAL & PROPRIETARY TO JUPITER AVIONICS CORP. | | L00N3 | JRS14-001 | 2/2 |
| | | DOC NO. JRS14-001 Interconnect Rev B.dwg | | |

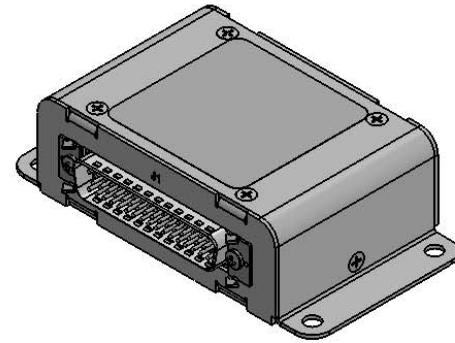
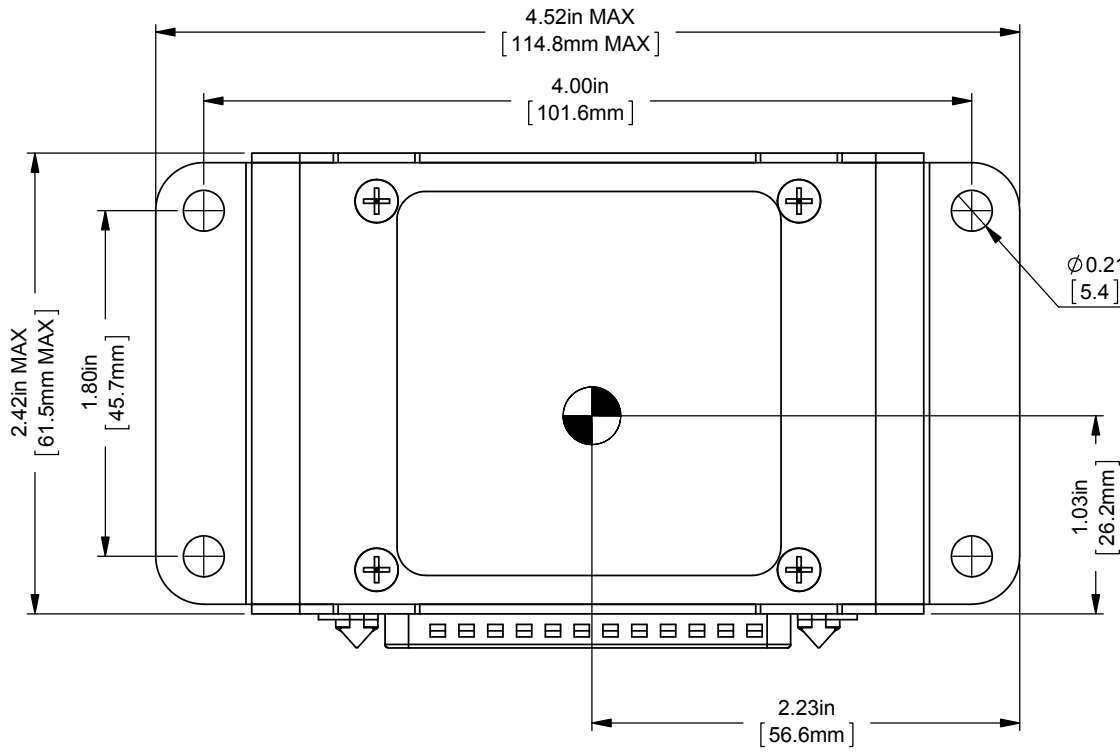

● CENTER OF GRAVITY
±0.03in [0.8mm]

WEIGHT: 0.30 lbs [0.14 kg] MAX.

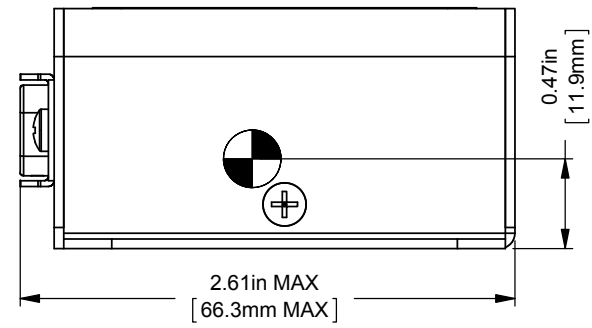
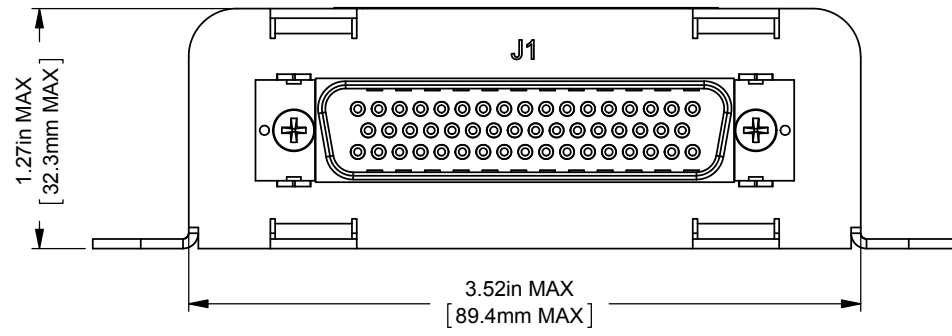

UNLESS OTHERWISE SPECIFIED
DIMENSIONS ARE IN INCHES
ANGLES ARE IN DEGREES
TOLERANCES:
1 DEC PLACE: ± 0.1
2 DEC PLACE: ± 0.01
3 DEC PLACE: ± 0.005
ANGLES: ± 0.5 DEG

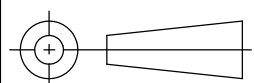

MATERIAL: N/A
FINISH: N/A

| | |
|---------------------------------------------------------------------------------|------------------------|
| PREPARED | TAT |
| CHECKED | JAC 12-17-13 DS |
| APPROVED | JAC 12-17-13 KDV |
| CONFIDENTIAL & PROPRIETARY TO JUPITER AVIONICS CORP. DRAWING NOT TO SCALE | |



| | | |
|------------------------------------------------------------|-----------------------|--------------|
| TITLE JRS14-001 Mechanical Installation | | |
| NCAGE CODE L00N3 | PART NO. JRS14-001 | SHEET 1/1 |
| DOC. NO. JRS14-001 Mechanical Installation Rev B.SLDDRW | | |