



JRS24-001 Data Transfer Switch JRS28-001 Data Transfer Switch

Data Sheet



Description

The JRS24-001 / JRS28-001 Transfer Switches are compact, high density, bulkhead mounted remote switching units designed to handle the switching requirements of navaid, audio or other interface applications. Both the JRS24 and JRS28 allow large numbers of data or audio lines to be transferred with a single control line. All relay switches have a contact rating of 1 amp / 30 vdc.

The JRS24 includes circuitry for flag load resistors and flag bias generators.

The JRS28 includes 4 extra poles of switching contacts and 2 flag bias generators.



JRS24/JRS28 Specifications

Installation

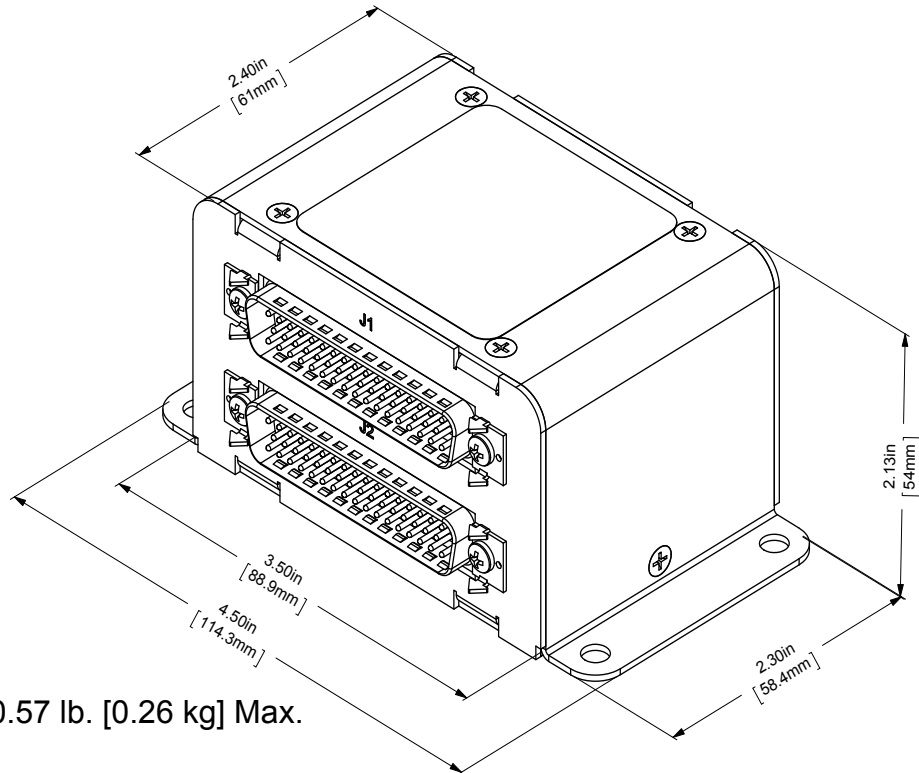

Weight: 0.57 lb. [0.26 kg] Max.

JRS24 Additional Circuitry

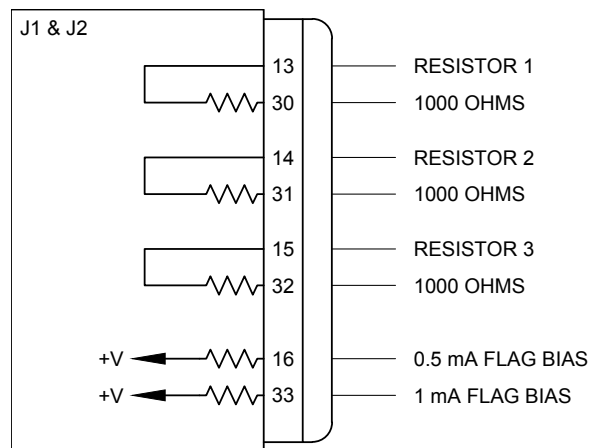

JRS28 Additional Circuitry

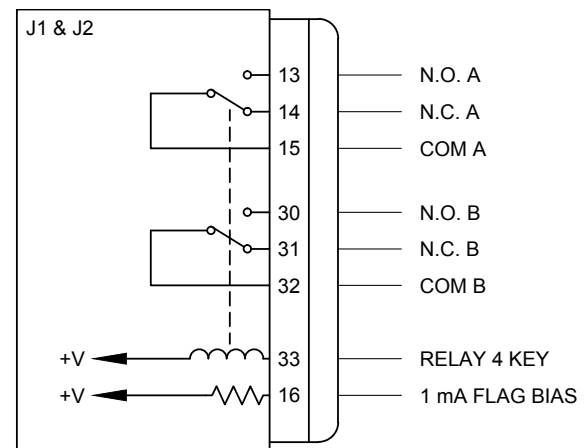

Environment and Performance

Operating Temperature	-40 C to +70 C
Survival Temperature	-55 C to +85 C
Altitude	50,000 ft. max
Humidity	95%, 48 hrs
Shock	20g (any axis)
TSO Compliance	CAN TSO-C139 (Pending)
Installation Kit	INST-JRS24 / INST-JRS28



JUPITER AVIONICS
C O R P O R A T I O N

JRS24-001 Relay Switch

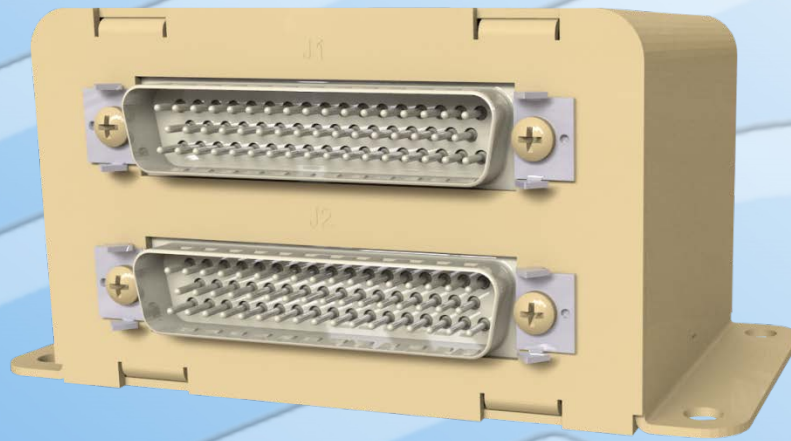

Installation and Operating Manual

Rev. C

Jupiter Avionics Corporation
1959 Kirschner Road
Kelowna BC
Canada V1Y 4N7
Tel: +1 778 478 2232
Toll-Free: 1 855 478 2232
www.jupiteravionics.com



Table of Contents

SECTION 1 - DESCRIPTION	1
1.1 System Overview	1
1.2 Features Overview	1
1.2.1 Functionality	1
1.2.2 Emergency procedures	1
1.3 Inputs and Outputs	2
1.3.1 Inputs	2
1.3.1 Outputs	2
1.4 Specifications	2
1.4.1 Electrical Specifications	2
1.4.2 Physical Specifications	3
1.4.3 Environmental Specifications	3
SECTION 2 – INSTALLATION	4
2.1 Introduction	4
2.2 Continued Airworthiness	4
2.3 Unpacking and Inspecting Equipment	4
2.3.1 Warranty	4
2.4 Installation Procedures	4
2.4.1 Cabling and Wiring	4
2.4.2 Mechanical Installation	5
2.4.3 Post Installation Checks	5
2.5 Adjustments	6
2.6 Installation Kit	6
2.6.1 Recommended Crimp tools	6
2.7 Installation Drawings	6
SECTION 3 – OPERATION	7
3.1 Introduction	7
Appendix A - Installation Drawings	A1
A1 Introduction	A1
A2 Installation Drawings	A1
Appendix B - Certification Documents	B1
B1 Airworthiness Approval	B2
B2 Instructions for Continued Airworthiness	B2



JRS24-001 Relay Switch

SECTION 1 - DESCRIPTION

1.1 System Overview

The JRS24-001 Relay Switch is a compact, high-density, bulkhead-mounted remote switching unit that provides twenty-four "C style" contacts to handle the switching requirements of navaid, audio, and other interface applications. It allows up to 24 data or audio lines to be transferred with a single control line.

The JRS24-001 Relay Switch consists of two completely independent units packaged in one enclosure.

1.2 Features Overview

The JRS24-001 features industry standard interconnects to allow easy field upgrades.

The JRS24-001 provides switching for 24 poles of information, organized as six groups of 2PDT relays, each with an individual key line. Each group can be used independently, can be picked as two groups (12 contact sets) or can be picked as one group by applying the required logic level to the appropriate ALL GROUP KEY line.

This relay switch can be used for applications from dry circuit to 0.5 A switching, but are limited to a maximum of 30 Vdc. They can be operated from +18 to +33 Vdc without changing the interconnect.

All interconnect and relay contacts are gold plated. These mechanical relays are sealed, high vibration rated (50g shock), dry nitrogen filled units.

All relay switches have a contact rating of 1 amp/30 Vdc

1.2.1 Functionality

The JRS24-001 provides remote switching of navigation or audio signals to allow system expansion or interconnection. Once installed, they operate independently to provide the required switching functions without any operator action.

1.2.2 Emergency procedures

The JRS24-001 does not affect the emergency procedures of the aircraft. If the unit is used to switch navigation signals, flight personnel should be made aware of its function.



1.3 Inputs and Outputs

Refer to the JRS12-001 or JRS24-001 connector map for the mating connector designators and pin assignments for the input and output signals. The JRS24-001 consists of two completely independent JRS12-001 units packaged in one enclosure, and therefore the quantities of each signal type should be doubled for this unit.

1.3.1 Inputs

Refer to the JRS12-001 or JRS24-001 connector map drawing for the mating connector designators and contact assignments for the JRS24 input signals.

Input	Quantity	Type
GROUP KEY	6	active low
ALL GROUP KEY	2	active low
POWER INPUT and POWER GROUND	4	power
Signal inputs	24	common

1.3.1 Outputs

Refer to the JRS12-001 or JRS24-001 connector map drawing for the mating connector designator and contact assignments for the JRS24 output signals.

Output Type	Quantity
Normally open signal outputs	24
Normally closed signal outputs	24
Bias voltage output contacts	4

1.4 Specifications

1.4.1 Electrical Specifications

Power Input

Nominal voltage	28 Vdc
Maximum voltage	30.3 Vdc
Minimum voltage	22.0 Vdc
Emergency voltage	18.0 Vdc
Input current	≤ 0.2 A max @ 28 Vdc

1.4.1.1 Audio Performance

Rated Input Level

Audio rated input level	7.75 Vrms±10%
-------------------------	---------------

Rated Output Power

Audio rated output power	7.75 Vrms±10%
--------------------------	---------------

Audio Frequency Response

Audio output audio frequency response	≤ 3dB from 300 to 6000 Hz
---------------------------------------	---------------------------



Distortion Characteristics

Audio output distortion at rated power	≤10%
Audio output distortion at 10% of rated power	≤ 3%

Input to output Crosstalk and Bleed-through Level ≤ 55 dB

Input to Input Crosstalk Level

Input to Input crosstalk	≤ 60 dB
--------------------------	---------

Audio Noise Level without Signal

Noise level below the rated output	≥ 60 dB
------------------------------------	---------

1.4.1.2 Control Signal Performance

Discrete Signals

Active low control input shall be active when the signal is	≤ +3 Vdc
Active low control input shall be inactive when the signals is	≥ +10 Vdc
Active low control input signals, when active, shall source	≤ 20 mA
Output signals, when active, shall sink	≤ 1 A

1.4.2 Physical Specifications

Height (maximum)	54.0 mm [2.13"]
Overall depth (maximum)	65.5 mm [2.58"]
Width (maximum)	114.3 mm [4.50"]
Weight (maximum)	TBD
Material	brushed aluminum with conversion coating
Connectors	Two 50 pin D-Sub male, V5 locking
Mounting	4 10-32 screws
Bonding	≤ 2.5 mΩ
Installation kit part number	INST-JRS2x

JRS24-001 Relay Switch

SECTION 2 – INSTALLATION

2.1 Introduction

This section contains unpacking and inspection procedures, installation information, and post-installation checks.

2.2 Continued Airworthiness

Maintenance of the JRS12-001 and JRS24-001 is on condition only. Scheduled inspection and/or periodic maintenance of this unit is not required.

2.3 Unpacking and Inspecting Equipment

Unpack the equipment carefully. Check for shipping damage and report any problems to the relevant carrier. Confirm that the Authorized Release Certificate or Certificate of Conformance is included. Complete the on-line warranty card from the Jupiter Avionics Corporation (JAC) website – www.jupiteravionics.com/warranty.

2.3.1 Warranty

All products manufactured by JAC are warranted to be free of defects in workmanship or performance for 2 years from the date of installation by an approved JAC dealer or agency. This warranty covers the cost of all materials and labour to repair or replace the unit, but does not include the cost of transporting the defective unit to and from JAC or its designated warranty repair centre, or of removing and replacing the defective unit in the aircraft. This warranty does not cover failures due to abuse, misuse, accident, or unauthorized alteration or repairs.

THIS WARRANTY IS VOID IF THE PRODUCT IS NOT INSTALLED BY AN AUTHORIZED JAC DEALER. If the on-line warranty card is not completed, the product will be warranted from the date of manufacture.

Contact JAC for return authorization, and for any questions regarding this warranty and how it applies to your unit(s). JAC is the final arbiter concerning warranty issues.

2.4 Installation Procedures



CAUTION: The power input circuitry of the unit may be damaged if the installation does not conform to the wiring instructions and circuit breaker rating in this manual.

2.4.1 Cabling and Wiring

All wire shall be selected in accordance with the original aircraft manufacturer's maintenance instructions, or AC43.13-1B Change 1, Paragraphs 11-76 through 11-78. Unshielded wire types shall qualify to MIL-W-22759 as specified in AC43.13-1B Change 1, Paragraphs 11-85, 11-86, and listed in Table 11-11. For shielded wire applications, use Tefzel MIL-C-27500 shielded wire with solder sleeves (for shield terminations) to make the most compact and easily terminated interconnect. Follow the Connector Map in Appendix A of this manual.

Allow 3" from the end of the shielded wiring to the shield termination to allow the connector hood to be easily installed. Refer to the Interconnect drawing in Appendix A of this manual for shield termination details. Note that this unit has a 'clamshell' hood that is installed after the wiring is complete.

Maintain wire segregation and route wiring in accordance with the original aircraft manufacturer's maintenance instructions.

Unless otherwise noted, all wiring shall be a minimum of 24 AWG, except power and ground lines, which shall be a minimum of 20 AWG. Refer to the Interconnect drawing for additional specifications. Check that the ground



connection is clean and well secured, and that it shares no path with any electrically noisy aircraft accessories such as blowers, turn-and-bank instruments, or similar loads.

2.4.2 Mechanical Installation

The JRS12-001 can be mounted in any attitude and location with adequate space and sufficient clearance for the connector and wiring harness. It requires no direct cooling and no shock or vibration isolators are required.

2.4.2.1 Installation Considerations

If the JRS12-001 or JRS24-001 is to be used for NAV switching, for instance linking two sources to a common indicator, this must be clearly marked and placarded in the aircraft. External annunciation of any NAV source must comply with section 2.4.1 of this manual.

If the unit is to be used for GPS/VLF switching, it may be necessary to wire the unit to ensure that it returns to the VOR/ILS mode when the navigation receiver is tuned to an ILS frequency. Check local aviation regulations regarding this requirement.



NOTE: ILS reversion mode for NAV/GPS installations is not applicable in Canada.

2.4.2.2 External Switches and Lamps

All switches and/or annunciators must be selected to suit the application. A single pushbutton or toggle switch may be used to supply the ALL KEY line to allow all lines to be selected together. If a single switch or lamp assembly is used to replace the transfer switch and annunciators, it should be a lighted pushbutton switch (SPST/SPDT) with a positive action (i.e. push on/push off) with two legends to match the required NAV functions.

If the unit is to be used as audio key relays for boom mics etc., the unit can be triggered by in-line drop cords or similar ways that supply an input to the appropriate key line.

If it is to be used as a NAV selector, annunciator lights should be connected through one or more relay contacts to ensure correct indication of the actual relay contacts.

2.4.3 Post Installation Checks

2.4.3.1 Voltage/Resistance checks.

Do not attach this unit until the following conditions are met:

- a) Check P1 pin **17** for +28 Vdc relative to ground.
- b) Check P1 pin **34** for continuity to ground (less than 0.5 Ω).
- c) Check all pins for shorts to ground or adjacent pins.

For the JRS24-001, repeat this procedure for connector P2.

2.4.3.2 System Operation

All operation is described with aircraft electrical power supplied, unless stated otherwise.

Individual Relay Key Operation

The individual relay common contacts connect to the Normally Open signal contacts when the RELAY (1 thru 3) KEY input is active.

The individual relay common contacts connect to the Normally Closed signal contacts when the RELAY (1 thru 3) KEY input is not active.

All Relay Key Operation

The all relay common contacts connect to the Normally Open signal contacts when the RELAY ALL KEY input is active.

Load Resistor Operation

The load resistors provide an electrical load resistance on a continuous basis.



Bias Resistor Operation

The bias resistors provide an electrical current on a continuous basis

2.4.3.3 Power on Checks.

Power up the aircraft's systems and check that all switching functions transfer correctly with the appropriate relay action. If the internal flag bias is used for indicator interfacing, ensure that this function works correctly, and only in the selected or transferred position.

When all performance checks are satisfied, complete the necessary regulatory documentation before releasing the aircraft for service.

2.5 Adjustments

The JRS12-001 and JRS24-001 units have no internal mechanical adjustments.

2.6 Installation Kit

The kit required to install this unit is not included with the unit.

The JRS24 requires installation kit (Part # INST-JRS2x) which consists of the following:

<u>Quantity</u>	<u>Description</u>	<u>JAC Part #</u>
2	D-sub 50-pin Connector Assembly	CON-3420-0050
2	TAG ring	CON-5500-0625
2	Heatshrink Tubing	WIR-HTSK-1000

2.6.1 Recommended Crimp tools

Connector Type	Hand crimp tool	Positioner	Insertion/extraction tool
Positronic	9507	9502-3	M81969/1-04

2.7 Installation Drawings

The drawings and documents required for Installation can be found in [Appendix A](#) of this manual.



JRS24-001 Relay Switch

SECTION 3 – OPERATION

3.1 Introduction

The JRS24-001 has no operator controls.

If any switches or indicators have been installed to control or indicate the function of the unit, confirm their operation with the installing agency and ensure that the relevant information has been added to the flight manual where necessary.



Installation and Operating Manual

Appendix A - Installation Drawings

A1 Introduction

The drawings necessary for installation and troubleshooting of the JRS12-001 Relay Switch and JRS24-001 Relay Switch are in this Appendix, as listed below.

The JRS24-001 Relay Switch consists of two completely independent JRS12-001 units packaged in one enclosure.

A2 Installation Drawings

DOCUMENT	REV
JRS24-001 Connector Map	A
JRS24-001 Interconnect	A
JRS24-001 Mechanical Installation	B

P1

50 PIN FEMALE DMIN
MATING CONNECTOR

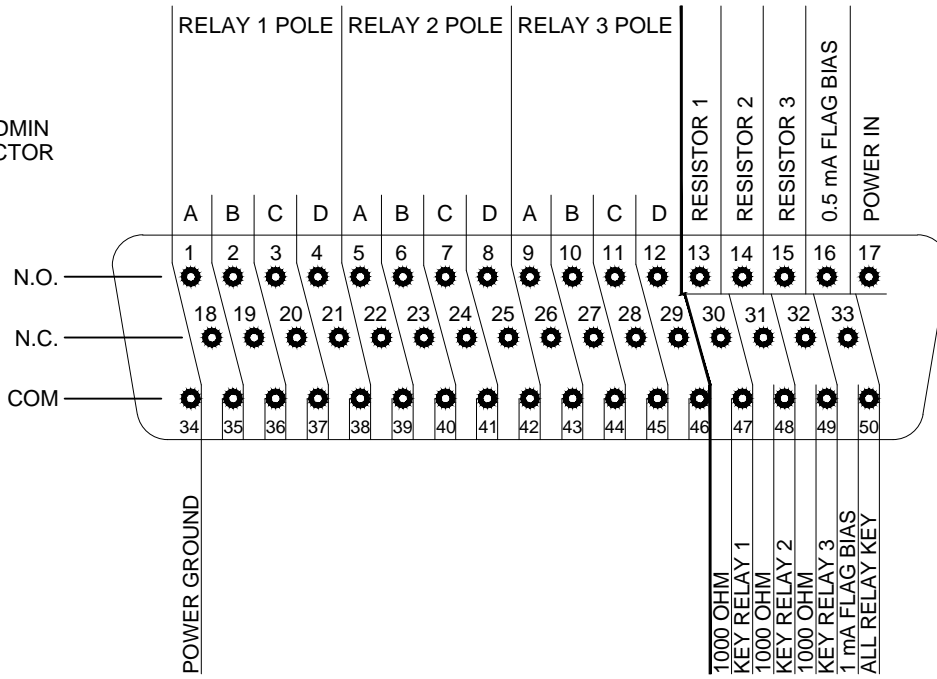

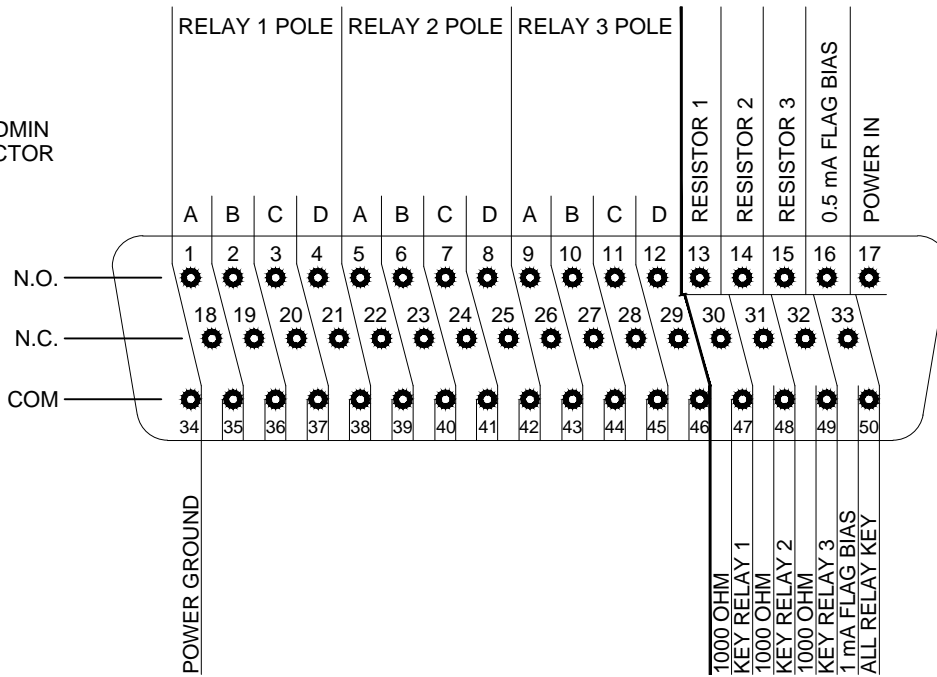

P2

50 PIN FEMALE DMIN
MATING CONNECTOR





VIEW IS FROM REAR OF MATING CONNECTOR

PREPARED	TAT				
CHECKED					TITLE
APPROVED		NCAGE CODE	PART NO.	SHEET	
CONFIDENTIAL & PROPRIETARY TO JUPITER AVIONICS CORP.		L00N3	JRS24-001	1/1	
		DOC NO. JRS24-001 Connector Map Rev A.dwg			

JRS24-001 INTERCONNECT WIRING NOTES

NOTES

1. ALL WIRE SIZE SHOULD BE 24 AWG MIN UNLESS OTHERWISE SPECIFIED. UNSHIELDED WIRE SHOULD BE SELECTED PER FAA AC43.13-1B CHANGE 1 PARA 11-76 TO 11-78. WIRE TYPES SHOULD BE IN ACCORDANCE WITH MIL-W-22759 AS DESCRIBED IN FAA AC43.13-1B CHANGE 1 PARA 11-85 AND 11-86 AND LISTED IN TABLE 11-11 OR 11-12. ALL SHIELDED CABLE SHOULD BE IN ACCORDANCE WITH MIL-DTL-27500 (REVISION H OR LATER).
- △ 2 CONNECTION TO AIRFRAME GROUND SHOULD BE MADE WITH 20 AWG WIRE. LENGTH NOT TO EXCEED 3 FT (1 M).

PREPARED	TAT			
CHECKED				
APPROVED		Relay Switch 24 Contacts		SHEET
CONFIDENTIAL & PROPRIETARY TO JUPITER AVIONICS CORP.		NCAGE CODE L00N3	PART NO. JRS24-001	1/3
		DOC NO. JRS24-001 Interconnect Rev A.DWG		

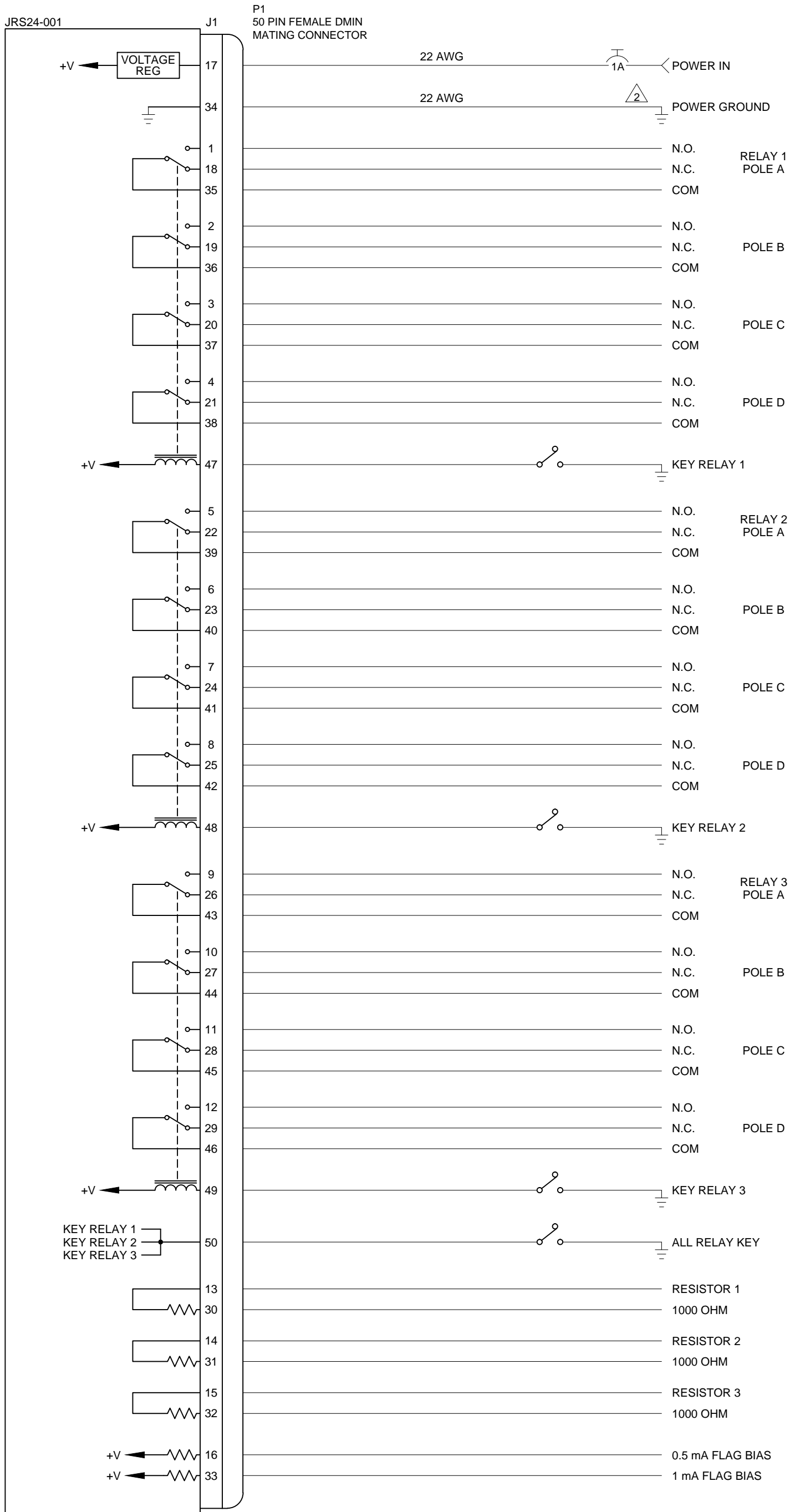

PREPARED	JAC 12-13-13 DS			TITLE Relay Switch 24 Contacts
CHECKED	JAC 12-16-13 KDV			
APPROVED	JAC 12-16-13 KDV	NCAGE CODE L00N3	PART NO. JRS24-001	SHEET 2/3
CONFIDENTIAL & PROPRIETARY TO JUPITER AVIONICS CORP.		DOC NO. JRS24-001 Interconnect Rev A.DWG		

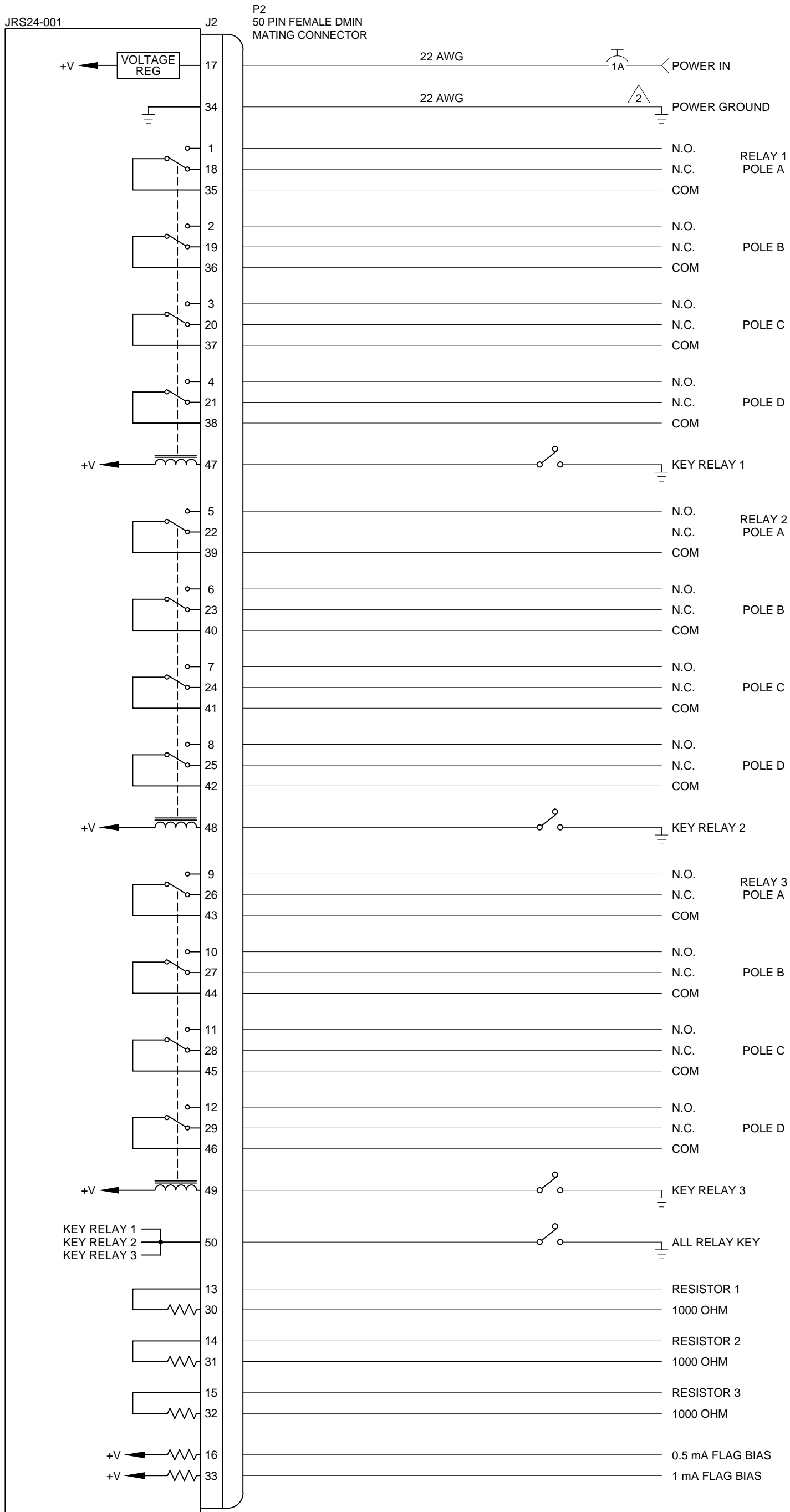

PREPARED	JAC 12-13-13 DS			TITLE Relay Switch 24 Contacts
CHECKED	JAC 12-16-13 KDV			
APPROVED	JAC 12-16-13 KDV	NCAGE CODE L00N3	PART NO. JRS24-001	SHEET 3/3
CONFIDENTIAL & PROPRIETARY TO JUPITER AVIONICS CORP.		DOC NO. JRS24-001 Interconnect Rev A.DWG		

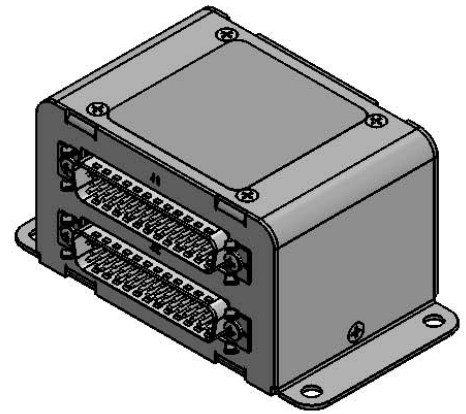
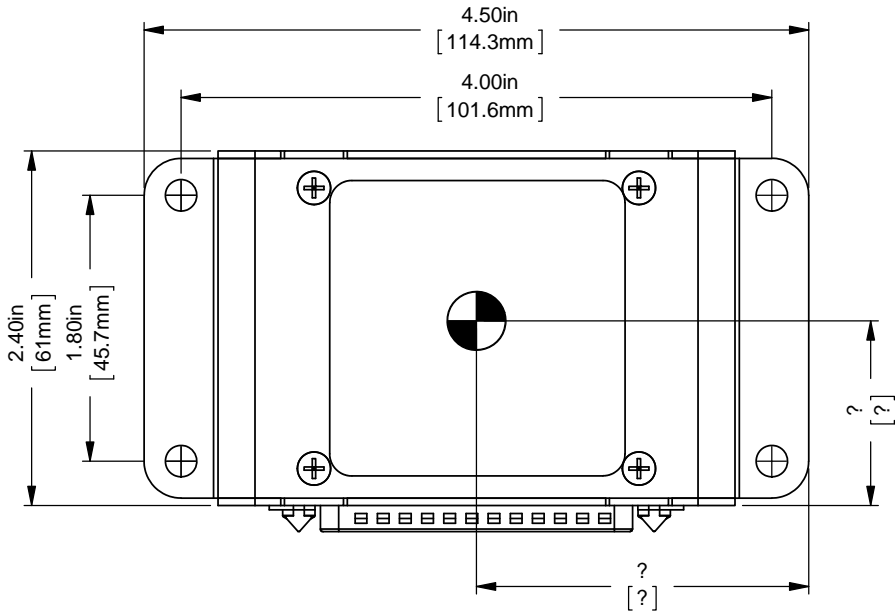

 CENTER OF GRAVITY
±0.03in [0.8mm]

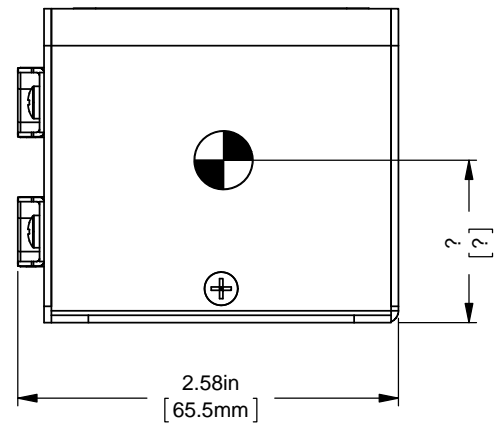
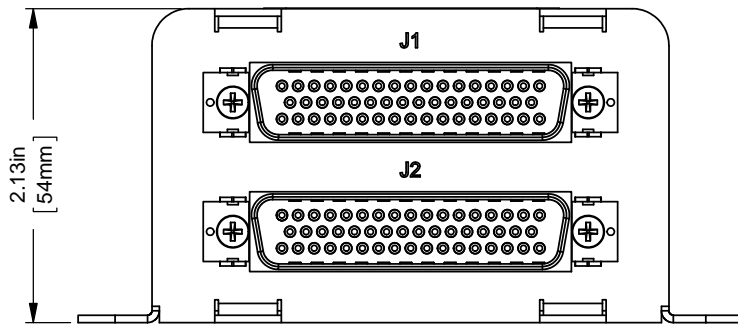

UNLESS OTHERWISE SPECIFIED
DIMENSIONS ARE IN INCHES
ANGLES ARE IN DEGREES
TOLERANCES:
1 DEC PLACE: ± 0.1
2 DEC PLACE: ± 0.01
3 DEC PLACE: ± 0.005
ANGLES: ± 0.5 DEG

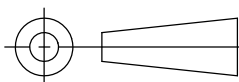

MATERIAL: N/A
FINISH: N/A

PREPARED	TAT
CHECKED	
APPROVED	
CONFIDENTIAL & PROPRIETARY TO JUPITER AVIONICS CORP. DRAWING NOT TO SCALE	



JUPITER AVIONICS
CORPORATION

TITLE

JRS24-001 Mechanical Installation

NCAGE CODE
L00N3

PART NO.
JRS24-001

SHEET
1/1

DOC. NO.

JRS24-001 Mechanical Installation Rev B.SLDDRW



Installation and Operating Manual

Appendix B - Installation Documents



B1 Airworthiness

Airworthiness approval of the JRS24 may require completion of a TCCA Major Modification Report per CAR STD (AWM) 571 Appendix L, or a FAA Form 337. The sample wording for a description of the work is provided to assist the Installing Agency in preparing Instructions for Continued Airworthiness (ICA) when replacing an existing Alert Generator with a Jupiter Avionics JRS12/24 Relay Switch. This sample may be modified appropriately for new installations. It is the installer's responsibility to determine the applicability of the method used. Installations performed outside Canada must follow the applicable aviation authority's regulations.

Sample Wording:

Removed the existing [model] equipment and replaced with a Jupiter Avionics JRS24 Relay Switch in [aircraft location].

Installed in accordance with the JRS24 Installation Manual, Revision [], and AC 43.13-2, Chapters 2, and 3.

The JRS24 interfaces with existing aircraft equipment per the Installation Manual instructions.

The JRS24 Installation Manual provides detailed installation instructions and wiring diagrams (Section 2, and Appendices A and B).

Power is supplied to the JRS24 through an existing []-Amp circuit breaker that was previously used by the original equipment. The net electrical load is unchanged.

Aircraft equipment list, weights and balance amended. Compass compensation checked and found to conform to applicable regulations.

B2 Instructions for Continued Airworthiness

Maintenance of the JRS24 Relay Switch is "on condition" only. Refer to the JRS24 Maintenance Manual. Periodic maintenance of the JRS24 is not required.

The following sample Instructions for Continued Airworthiness (ICA) provides assistance in preparing ICA for the Jupiter Avionics JRS24 unit installation as part of a Type Certificate (TC) or Supplemental Type Certificate (STC) project to comply with CAR STD (AWM) 523/527/525/529.1529 or FAR 23/25/27/29.1529 "Instructions for Continued Airworthiness".

Items that may vary by aircraft make and model are shown in brackets ("[]") and should be filled in as appropriate. Some of the checklist items do not apply, in which case they should be marked "N/A" (Not Applicable).

Instructions for Continued Airworthiness, Jupiter Avionics JRS24 Relay Switch in an [Aircraft Make and Model]

1. Introduction

[Aircraft that has been altered: Registration number, Make, Model and Serial Number]

Content, Scope, Purpose and Arrangement: This document identifies the Instructions for Continued Airworthiness for a Jupiter Avionics JRS24 installed in an [aircraft make and model].

Applicability: Applies to a Jupiter Avionics JRS24 installed in an [aircraft make and model].

Definitions/Abbreviations: None, N/A.

Precautions: None, N/A.

Units of Measurement: None, N/A.

Referenced Publications: JRS24 Installation and Operating Manual

JRS24 Maintenance Manual

STC/TC # [applicable STC/TC number for the specific aircraft installation]

Distribution: This document should be a permanent aircraft record.



2. Description of the System/Alteration

Jupiter Avionics JRS24 Relay Switch with interface to external transceivers and [include other equipment/systems as appropriate]. Refer to Appendix A of this manual for interconnect information. Refer to aircraft manufacturer approved interconnect for actual installation.

3. Control, Operation Information

Refer to section 3 of this manual or to the Jupiter Avionics JRS24 Operating Manual.

4. Servicing Information

N/A

5. Maintenance Instructions

Maintenance of the JRS24 is 'on condition' only. Periodic maintenance is not required. Refer to the JRS24 Maintenance Manual.

6. Troubleshooting Information

Refer to the JRS24 Maintenance Manual.

7. Removal and Replacement Information

Refer to Section 2 of this manual - the JRS24 Installation and Operating Manual. If the unit is removed and reinstalled, a functional check of the equipment should be conducted.

8. Diagrams

Refer to Appendix A of this manual - the JRS24 Installation and Operating Manual - for installation drawings and interconnect examples.

9. Special Inspection Requirements

N/A

10. Application of Protective Treatments

N/A

11. Data: Relative to Structural Fasteners

JRS24 and appropriate mounting hardware installation, removal and replacement should be in accordance with applicable provisions of AC 43.13-1B and AC 43.13-2A.

12. Special Tools

N/A

13. This Section is for Commuter Category Aircraft Only

A. **Electrical loads:** Refer to Section 1 of the JRS24 Installation and Operating Manual.

B. **Methods of balancing flight controls:** N/A.

C. **Identification of primary and secondary structures:** N/A.

D. **Special repair methods applicable to the airplane:** N/A.

14. Overhaul Period

No additional overhaul time limitations.

15. Airworthiness Limitation Section

N/A