



wiJAC™ -Dxx

Wireless Intercom System - Wireless Dropcord Data Sheet

**BOTH RADIO
AND INTERCOM
PTT INCLUDED!**



Description

The wiJAC™ Wireless Dropcord System consists of two components which provide a wireless full-duplex audio link between the aircraft's intercom / radio systems and the user's headset. Adapters are available for different headset connector styles. The JA69 component plugs directly into the aircraft audio system via a standard dropcord jack and the JA68 component connects to a standard aircraft headset and attaches to the user's belt. Together the two separate components allow aircraft personnel free movement both inside and outside the aircraft. The headset adapter features only essential controls to ensure ease of operation. As well as VOX and Volume controls, the JA68 has two PTT buttons: one for ICS PTT and one for TX (Radio) PTT. When TX PTT is activated, the microphone audio is transmitted to the aircraft audio controller and then to the selected aircraft radio.

The wiJAC™ system offers the user independence from traditional tethered audio systems without sacrificing audio quality.

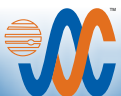

Features

The wiJAC™ system is factory programmed with default settings that are suitable for most general aviation high impedance headsets. If it is necessary to modify the balanced phones/microphone input/output levels, this can be carried out by a JAC Dealer using JAC's proprietary ProCS™ software. A configuration port is provided to support this function.

A light on each unit indicates when the RF communication link is established, and a micro USB charging port is provided for connection to a USB charging source. Charging cables and rechargeable batteries are included with each system.

Multiple paired adapters can be co-located in the same aircraft without interference. An encrypted radio link ensures secure communications. A selection of adapter cables is available for use with other connector styles.

The wiJAC-D01 system comprises of a JA68-001 and a JA69-001 and is for use in North America.

The wiJAC-D02 system comprises of a JA68-002 and a JA69-002 and is for European use.

wiJAC™-Dxx Specifications Installation / Environment & Performance

U-92A/U type connector mates with U93A/U and equivalent

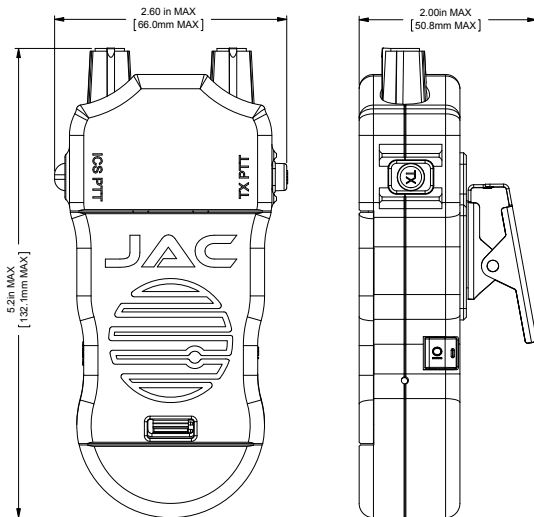

JA68 Wireless Aircraft Headset Adapter
Weight: 0.46 lb. 0.209 Kg Max

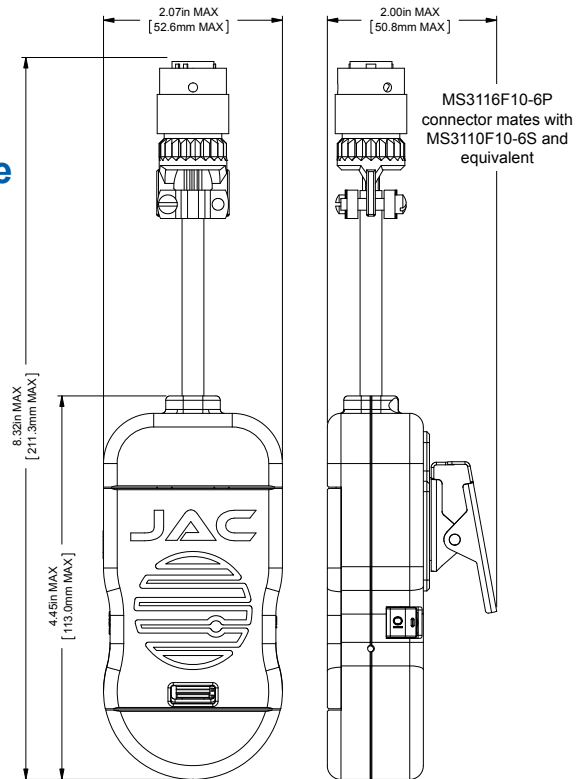

JA69 Wireless Aircraft Intercom Adapter
Weight: 0.33 lb. 0.149 Kg Max

Pin Out Standard	* US Forest Service	Type 1 Bell	Type 2	Type 3	Type 4
Pin A:	Phones Lo (GND)	MIC Hi	MIC Hi	MIC Lo (GND)	TX Key
Pin B:	MIC Hi	TX Key	ICS Key	Phones Hi	ICS Key
Pin C:	MIC Lo (GND)	MIC Lo (GND)	MIC Lo (GND)	Phones Lo (GND)	Phones Hi
Pin D:	Phones Hi	ICS Key	TX Key	MIC Hi	MIC Lo (GND)
Pin E:	TX Key	Phones Hi	Phones Hi	ICS Key	Phones Lo
Pin F:	ICS Key	Phones Lo (GND)	Phones Lo (GND)	TX Key	MIC Hi

* Default wiring for JA69

Batteries	6 ea. AAA, (3 per unit)
Charging Electrical Power	+5 Vdc @ 200mA max (USB Power Source)
Temperature	-15 °C to +50 °C -40 °C to +50 °C
Altitude	25,000 ft. max
Humidity	95%
Microphone	150 Ohms amplified Dynamic

Vibration	Per DO160G Cat [(SBM)(U2FF1)]
Range wiJAC-D01	100 m (typical)
Range wiJAC-D02	200 m (typical)
Battery Life	6 to 8 hr (typical)
Shock	20g (any axis)
Headphone	100 mW into 150 Ohms



Printed in Canada



JUPITER AVIONICS
CORPORATION

wiJAC-D01

Wireless Intercom Dropcord System – N America



Operating Manual

Rev. A



**Copyright 2014 Jupiter Avionics Corp.
 All rights reserved**

Jupiter Avionics Corporation (JAC) permits a single copy of this manual to be printed or downloaded for personal use. Any such electronic or printed copy of this manual must contain the complete text of this copyright notice. Any unauthorized commercial distribution of this manual is strictly prohibited. Except as described above, no part of this manual may be reproduced, copied, transmitted, disseminated, downloaded, or stored in any storage medium for any purpose without the express prior written consent of JAC.

IMPORTANT:

Information in this manual is subject to change without notice.

To check the current revision status of this manual, visit the JAC website:
www.jupiteravionics.com

Record of Revisions			
Rev	Date	Description	ECR
A	May 2014	Initial release, serial number 1001 +	2867



Prepared: MPB	Checked: 	Approved: 
----------------------	---	--



Table of Contents

1	Introduction.....	1
1.1	Unpacking.....	1
1.2	Verify Operating Region.....	1
1.3	Verify Pairing Registration Number.....	1
2	JA68-001 Headset Adapter	2
3	JA69-001 Intercom Adapter.....	2
4	Controls, Annunciators and Connectors	3
4.1	(ON/OFF) Button – Both units	3
4.2	Controls – JA68-001	3
4.2.1	VOX (Voice Operated Switch)	3
4.2.2	VOL (Phones Volume Control)	3
4.2.3	ICS PTT (Push To Talk) Button	3
4.2.4	TX PTT (Push To Talk) Button.....	3
4.3	Headset Jack – JA68-001.....	4
4.4	Intercom Connector – JA69-001	4
4.5	Connectors – Both units	4
4.5.1	IO Configuration Port (Dealers only)	4
4.5.2	PWR (Charging Port).....	4
4.6	Annunciators – Both Units	4
4.6.1	PWR ON (Power On).....	4
4.6.2	LOW BATT (Low Battery Warning)	4
4.6.3	Battery Charge (not shown)	5
4.7	Other.....	5
4.7.1	Pairing Registration Number.....	5
4.7.2	Battery Lid Release.....	5
4.7.3	Clothing/Mounting Clip.....	5
5	Connecting the wiJAC™ System	6
5.1	wiJAC™ Set-up and Connection.....	7
5.1.1	Insert Batteries.....	7
5.1.2	Attach Connectors to Aircraft and Headset.....	7
5.1.3	Turn On Adapters and Verify Connection	7
5.1.4	Verify Audio Operation.....	7
5.2	wiJAC™ System Operation.....	8
5.2.1	Overview	8
5.2.2	Listening Operation.....	8
5.2.3	VOX Speaking Operation.....	8
5.2.4	TX PTT or ICS PTT Speaking Operation	8
5.2.5	Live Speaking Operation.....	8
5.2.6	Low Battery Warning.....	8
5.2.7	Operation during Charging.....	9
5.2.8	Loss of Audio	9



5.2.9	Battery Life.....	9
6	Batteries	10
6.1	Inserting or Replacing the Batteries.....	10
6.2	Charging Batteries in the Unit.....	10
6.3	Charging Operation – via Battery Charger.....	11
6.4	Battery Cautions and Warnings	11
7	Accessories	12
7.1	JA72-005 Glove Box with USB connector.....	12
7.2	ProCS™ Product Configuration Software.....	12
7.3	Battery Charger Recommendations.....	12
8	FCC Compliance Statement.....	13



1 Introduction

This manual contains the operating instructions for the **wiJAC**-D01 Wireless Intercom Dropcord System – N America. The system consists of one JA68-001 Headset Adapter, and one JA69-001 Intercom adapter. Only paired units will operate together (see [section 1.3](#))

System operating information is in [section 5.2](#).



WARNING: JAC recommends that no battery operated device should be relied upon as the sole method of communication in cases where there is potential risk to life or limb.

1.1 Unpacking

Unpack the **wiJAC**™ box carefully, and ensure that it contains the following:

- one ea. Wireless Aircraft Headset Adapter, JAC P/N JA68-001
- one ea. Wireless Aircraft Intercom Adapter, JAC P/N JA69-001
- two pkg. of AAA rechargeable batteries, JAC P/N MSC-BATT-AAA
- two ea. USB to Micro USB cables, JAC P/N CAB-USB-0003
- one **wiJAC**™ Quick Start Guide, JAC P/N DOC-GUID-WID01U

1.2 Verify Operating Region

The **wiJAC**-D01 Wireless Intercom System operates using radio frequencies that are authorized by government regulatory agencies. Ensure the region in which you are operating the units matches the region marked on a label on the back of each unit.

1.3 Verify Pairing Registration Number

The **wiJAC**™ Wireless Intercom System consists of one set of paired Adapters. The JA68-001 Headset Adapter and JA69-001 Intercom Adapter will only operate together when paired. Ensure that the same three character Pairing Registration Number is marked on a label on the back of each unit.



2 JA68-001 Headset Adapter

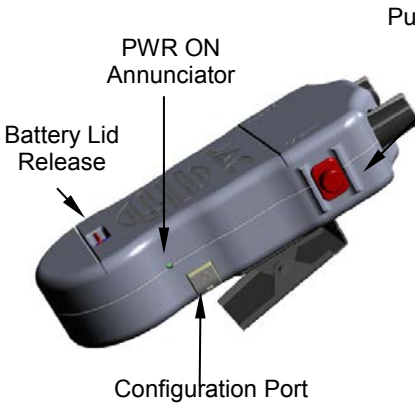

Fig 2-1, JA68 Right Side View



Fig 2-2, JA68 Left Side View

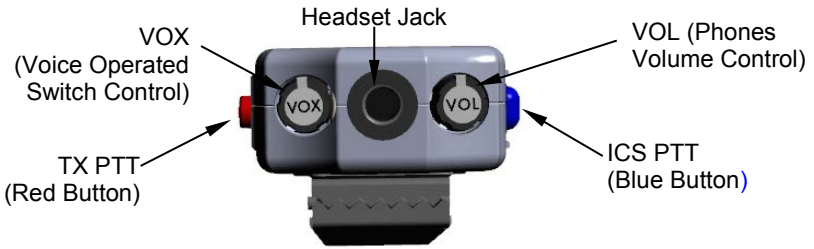

Fig 2-3, JA68 Top View

3 JA69-001 Intercom Adapter

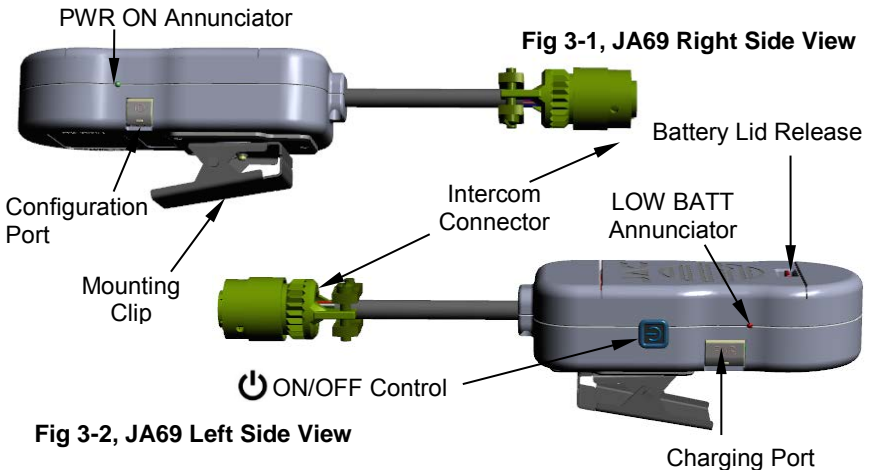

Fig 3-1, JA69 Right Side View

Fig 3-2, JA69 Left Side View



Note: The units are shown in grey for clarity



4 Controls, Annunciators and Connectors

4.1 (ON/OFF) Button – Both units

The ON/OFF control is a push button switch marked with the  symbol and is located on the left side of the unit. To turn the unit on, press the ON/OFF button once. To turn the unit off, press and hold the ON/OFF button until the PWR ON and LOW BATT annunciators turn off (approximately three to five seconds).

4.2 Controls – JA68-001

4.2.1 VOX (Voice Operated Switch)

The Voice Operated Switch control is a rotary knob marked VOX located on the top of the JA68-001 Headset Adapter. To reduce the level of the sound needed to route the microphone audio to the Intercom Adapter, turn the VOX knob counterclockwise. To increase the level of the sound needed to route the microphone audio to the Intercom Adapter, turn the VOX knob clockwise. Adjust this setting for proper VOX operation as ambient noise levels change.

4.2.2 VOL (Phones Volume Control)



WARNING: Loud noise can cause hearing damage. Before using the headset, set the volume to minimum, and then slowly increase it to a comfortable listening level.

The volume control is a rotary knob marked VOL (volume) located on the top of the JA68-001 Headset Adapter. To reduce the volume of the audio heard in the headset rotate the VOL knob counterclockwise. To increase the volume of the audio heard in the headset rotate the VOL knob clockwise.

4.2.3 ICS PTT (Push To Talk) Button

The intercom Push To Talk button is a blue convex push button switch located on the right side of the JA68-001 Headset Adapter. The ICS PTT markings are located on the back and front of the unit. When the ICS PTT button is pressed and held, the VOX threshold is overridden, microphone audio is routed to the paired JA69-001 Intercom Adapter, and the ICS Key output is activated.

4.2.4 TX PTT (Push To Talk) Button

The Transmit Push To Talk button is a red cylindrical push button switch on the left side of the JA68-001 Headset Adapter. The TX PTT marking is located on the front and back of the unit. When the TX PTT button is pressed and held, microphone audio is routed to the Intercom Adapter and the TX Key output is activated.

This is the user's Transmit 'Press-to-talk' (TX PTT) button. While this button is pressed, the **wiJAC**-D01 system will allow the user to transmit on the transceiver selected on the audio controller. If the TX PTT button is used, the VOX threshold will be overridden (see section 4.2.1 above).



4.3 Headset Jack – JA68-001

The headset jack is a TJT120 type connector on the top of the JA68-001 headset adapter. Insert a U-174/U or U93A/U type Headset plug into the JA68-001 Headset Adapter headset jack.

4.4 Intercom Connector – JA69-001

The JA69-001 Intercom Adapter connects to the aircraft audio panel via a six pin MS Connector.

4.5 Connectors – Both units

4.5.1 IO Configuration Port (Dealers only)

This port is used by Approved dealers and installers to connect the unit to a laptop or PC to enable configuration changes using the ProCS™ program.

4.5.2 PWR (Charging Port)

The Charging Port is a Micro-USB connector with a flexible cover labeled PWR (power) on the left side of the unit. To charge NiMH batteries, connect a USB (Universal Serial Bus) to Micro USB cable from the Charging Port to a USB power source.



WARNING: Charging battery types other than NiMH or NiCad may cause the batteries to leak or explode and cause damage or injury. If non-NiMH or non-NiCad batteries are installed, do not connect the Charging Port to a USB power source.

4.6 Annunciators – Both Units

4.6.1 PWR ON (Power On)

The power on (PWR ON) annunciator is a green LED located on the right side of the unit. In addition to indicating that the unit is turned on, this annunciator indicates the connection status of paired units (see [section 5.1.3](#))

4.6.2 LOW BATT (Low Battery Warning)

The low battery (LOW BATT) annunciator is a red LED located on the left side of the unit. When a unit is turned on, the LOW BATT annunciator will illuminate for 2 seconds.

When the JA68 battery voltage is low the LOW BATT annunciator will flash once every 1.5 s and a low battery notification (a triple beep) will be heard in the headphones once every minute. (A similar but higher pitched tone will be heard if the paired Intercom Adapter battery charge is low.)

When the unit battery charge is less than or equal to the critical battery voltage, the unit will turn off.



4.6.3 Battery Charge (not shown)

The JA68-001 Battery Charge annunciators are two LEDs, one on each side of the charging port under the flexible dust cover marked PWR.

The Fast Charge annunciator is a red light emitting diode (LED) that will illuminate when the batteries are being charged at the maximum charge current.

The Top-Off Charge annunciator is a green LED that will illuminate when Fast Charge mode is complete and the batteries are charged.

4.7 Other

4.7.1 Pairing Registration Number

The pairing registration number is marked on a label in on the back of each unit. A JA68-001 Headset Adapter will connect only to the Intercom Adapter with the same pairing registration number.

4.7.2 Battery Lid Release

The battery lid release is a lever on the front of the unit recessed into the battery lid (see section 6.1).

4.7.3 Clothing/Mounting Clip

The clothing clip is on the rear of the JA68-001 Headset Adapter, and the mounting clip is on the rear of the JA69-001 Intercom Adapter. Ensure that the units are attached securely.



5 Connecting the wiJAC™ System



Note: The **wiJAC-D0x** Wireless Intercom Dropcord System consists of one JA68-001 Headset Adapter and one JA69-001 Intercom Adapter. Only paired units will operate together (see [section 5.1.3](#))

The JA69-001 Intercom Adapter has a plug that is inserted into a jack in the aircraft where the headset dropcord is normally connected, and is then clipped to a suitable point in the aircraft. A headset is inserted into the jack on the JA68-001 Headset Adapter, which is clipped to the user's belt or clothing. **Headset and audio panel are not included.**



JA68-001 Headset Adapter
(Connected to user's headset)

JA69-001 Intercom Adapter
(Plugged in to aircraft intercom jack)



5.1 wiJAC™ Set-up and Connection

5.1.1 Insert Batteries

Ensure the batteries for both units are fully charged and installed in the battery compartment with the correct polarity, and the battery lid is secured (section 6).

5.1.2 Attach Connectors to Aircraft and Headset

Connect the JA69-001 Intercom Adapter plug to a MS3110 Flo-65 or equivalent connector.

Insert a headset with a U-174/U or U93A/U type plug into the JA68-001 Headset Adapter jack.

5.1.3 Turn On Adapters and Verify Connection

On the JA68-001 Headset Adapter, turn the VOL knob fully counterclockwise to minimum. Turn on the JA68-001 Headset Adapter and the JA69-001 Intercom Adapter. On both units the PWR ON and LOW BATT annunciators will illuminate for two seconds.

- When a unit is turned on, the PWR ON annunciator will illuminate for 2 seconds, and the unit will start to search for its paired unit.
- While the unit is searching for its paired unit the PWR ON annunciator will triple-flash every 1.5 seconds.
- When the unit is connecting to its paired unit, the annunciator will double-flash every 1.5 s until connection is established.
- After connection, the annunciator will illuminate steady green until the unit is turned off.

5.1.4 Verify Audio Operation

Set the aircraft audio system's VOX mode to live or key the aircraft audio system's ICS PTT for the headset connection used by the JA69-001 Intercom Adapter.

Adjust the JA68-001 Headset Adapter's VOX control to fully counterclockwise and the VOL control to achieve a comfortable listening level. Confirm that the microphone audio is live - all microphone audio is heard in the phones. Confirm that the audio level increases as the VOL control is rotated clockwise and decreases as the VOL control is rotated counterclockwise.

Adjust the Headset Adapter's VOX control to fully clockwise and confirm that the microphone audio is off.

Press the Headset Adapter's ICS PTT button and confirm that microphone audio is heard in the phones. Repeat this process for the TX PTT button.

Adjust the Headset Adapter's VOX control for a comfortable speaking level and return the aircraft audio system's controls to its previous settings.



5.2 wiJAC™ System Operation

5.2.1 Overview

When both units are turned on and connected, phones audio from the aircraft audio system is transmitted from the Intercom Adapter, received by the Headset Adapter and output on the headset's phones. Microphone audio from the headset's microphone is transmitted from the Headset Adapter, received by the Intercom Adapter and output to the aircraft's audio system.

5.2.2 Listening Operation

The Headset Adapter's Phones Volume (VOL) controls the level of audio heard in the headset's ear phones. As ambient noise levels change, the volume can be adjusted.

5.2.3 VOX Speaking Operation

To use the JA68-001 Headset Adapter hands-free, adjust the VOX control so that the microphone audio is turned on when speaking in to the headset's microphone at a comfortable level, or at a level to keep the ambient noise from turning on the microphone audio.

5.2.4 TX PTT or ICS PTT Speaking Operation

To use the JA68-001 Headset Adapter in high-noise environments, adjust the VOX control fully clockwise. To communicate, press and hold the JA68-001 Headset Adapter's ICS or TX PTT button and speak in to the headset's microphone.

5.2.5 Live Speaking Operation

To use the JA68-001 Headset Adapter so that the microphone audio is always turned on, adjust the VOX control fully counterclockwise.

5.2.6 Low Battery Warning

When the unit's battery charge is low, the LOW BATT annunciator will triple flash every 1.5 seconds. When the JA68-001 Headset Adapter battery charge is low, a triple-beep will be heard in the headset once every minute.



Note: JAC recommends that the batteries should be charged or replaced immediately when the LOW BATT warning illuminates during use.

When the battery charge level is critical, the unit will turn off. When one unit is off the other unit will begin searching for its paired unit and its PWR ON annunciator will flash.



5.2.7 Operation during Charging

The units will still operate while the Charging Port is connected to a USB power source, but the batteries will charge at a slower rate. Additional noise may be heard on the audio system while the Charging Port is connected to a USB power source.

5.2.8 Loss of Audio

If there is no audio heard in the headset, check the PWR ON annunciator on the JA68-001 Headset Adapter and the JA69-001 Intercom Adapter. If a unit is off, turn it on and verify connection and operation.

If the battery charge is low, replace or recharge the batteries or connect the headset directly to the aircraft audio system.

If audio is unintelligible, turn off and remove the JA68-001 Headset Adapter and the JA69-001 Intercom Adapter and connect the headset directly to the audio panel.

If another aircraft system is experiencing a fault, turn off and remove the JA68-001 Headset Adapter and the JA69-001 Intercom Adapter and connect the headset directly to the audio panel. Do not use the JA68-001 Headset Adapter and the JA69-001 Intercom Adapter if they appear to be the cause of the fault.

5.2.9 Battery Life

The operating duration of the **wiJAC**-D0x system with fully charged batteries before battery replacement is required depends on the following factors:

- **Distance between Headset Adapter and Intercom Adapter:**
The closer together the units are the lower the radio frequency (RF) power required for connection. This will increase the battery life.
- **Obstacles between the Headset Adapter and Intercom Adapter (VOL):**
Minimising the aircraft metal structures, human bodies, cargo and other obstacles between the units will reduce the RF power needed for connection and increase the battery life.
- **Charge capacity of the batteries installed:**
The higher the capacity of the batteries, typically specified as 500 to 1000 mAh (milliamp-hours), the longer the battery life.
- **The type of batteries installed and the operating temperature:**
During low temperature operation, rechargeable batteries will lose capacity. When operating in low temperatures use alkaline batteries for a longer battery life.
- **The phones volume level and usage rate:**
The lower the volume level and the less often audio is output to the phones, the longer the battery life.



6 Batteries



WARNING: Charging battery types other than NiMH or NiCad may cause the batteries to leak or explode and cause damage or injury. If non-NiMH or non-NiCad batteries are installed, do not connect the Charging Port to a USB power source.

The JA68-001 requires three AAA batteries. JAC recommends Duracell 800 mAh (or higher) NiMH or Duracell alkaline batteries for use in the **wiJAC™** system to obtain the typical battery life.

Removal of the batteries WILL NOT change any internal configuration of the unit.

6.1 Inserting or Replacing the Batteries

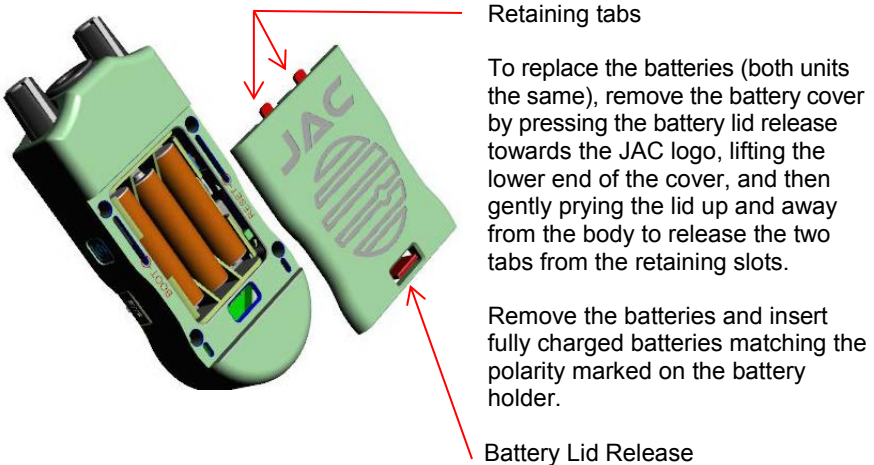

6.2 Charging Batteries in the Unit

To charge rechargeable batteries in the unit, connect the Charging Port to a USB power source using the USB to Micro-USB cable (CAB-USB-0003). If turned on during charging, the unit draws its power from the charging source, not the batteries, but battery charging will take longer. When charging is complete, the 'Top Off' Charge annunciator will illuminate green.

It should be possible to charge the unit via most USB power sources but this cannot be guaranteed for any products not made by or purchased from JAC. Where space allows, JAC recommends the JAC JA72-006 6 Dzus Glove Box with USB connector (see [section 7.1](#))



Note: The batteries will charge whether the JA68/JA69-001 is switched on or switched off. Battery charging will take longer if the unit is switched on.



6.3 Charging Operation – via Battery Charger

The batteries may be removed from the unit for charging in a separate battery charger. Removal of the batteries WILL NOT change any internal configuration of the unit.



Note: The JA68-001 and JA69-001 will only charge the batteries when the internal temperature is within 0 to 40 °C

6.4 Battery Cautions and Warnings



CAUTION: Follow these guidelines to prolong battery life and minimize the risk of unit malfunction.

- ⚠ Do not leave battery uncharged for long periods of time.
- ⚠ Do not leave battery charging for extended periods (more than 48 hours)
- ⚠ To ensure that the unit functions correctly, insert the new batteries with the positive and negative poles aligned as indicated in the battery compartment.
- ⚠ When replacing the batteries, use only new or fully charged batteries.
- ⚠ Do not mix old and new batteries as this can cause battery leakage and/or damage to the unit.
- ⚠ Do not mix battery types.



WARNING: Follow these guidelines to prolong battery life, and minimize the risk of fire, chemical burns, electrolyte leaks and/or injury.

- ❗ **FOLLOW** the manufacturer's instructions for care and disposal of batteries.
- ❗ **DO NOT** use sharp objects to remove the batteries.
- ❗ **DO NOT** disassemble, puncture, burn or in any other way damage the batteries.
- ❗ **DO NOT** let children handle the batteries.
- ❗ **USE ONLY** recommended battery chargers.
- ❗ **USE ONLY** recommended replacement batteries.



7 Accessories

7.1 JA72-005 Glove Box with USB connector



The JA72 Glove Box with USB Charger allows the aircraft owner/operator to utilize an empty portion of the instrument panel for storage.

A USB 2.0 Type A receptacle is provided to supply 5 Vdc power up to 2 Amps, and a 3.5mm stereo jack can be connected to the aircraft's audio system.

7.2 ProCS™ Product Configuration Software

ProCS™ Product Configuration Software and a ProCS™ connection cable are available to approved dealers and installers.

7.3 Battery Charger Recommendations

To charge AAA NiMH batteries, JAC recommends the charger should have individual cell charging (so that three batteries may be charged at once), an automatic shut-off feature and a charge time of two to six hours.

Always follow the manufacturer's recommendations for use of batteries and battery chargers.



8 FCC Compliance Statement

This device complies with Part 15 of the FCC Rules.

Operation is subject to the following two conditions:

- 1) this device may not cause harmful interference, and
- 2) this device must accept any interference received, including interference that may cause undesired operation of the device.

Module transmetteur ID IC: 9576A-SC14A

Son fonctionnement est soumis aux deux conditions suivantes:

- 1) cet appareil ne doit pas causer d'interférences nuisibles et
- 2) cet appareil doit accepter toute interference recue, y compris les interferences qui peuvent perturber le fonctionnement.

Changes or modifications to the equipment not expressly approved by the Party responsible for compliance could void the user's authority to operate the equipment.

NOTE: This equipment has been tested and found to comply with the limits for a Class B digital device, pursuant to Part 15 of the FCC Rules. These limits are designed to provide reasonable protection against harmful interference in a residential installation.

This equipment generates, uses and radiates radio frequency energy and, if not installed and used in accordance with the instructions, may cause harmful interference to radio communications. There is no guarantee that interference will not occur in a particular installation. If this equipment does cause harmful interference to radio or television reception, which can be determined by turning the equipment off and on, the user is encouraged to try to correct the interference by one or more of the following measures:

- Increase the separation between the equipment and the interfered receiver or antenna.
- Turn the equipment off and remove from the aircraft audio system. Connect the headset to the aircraft audio system.
- Consult Jupiter Avionics Corp or an experienced avionics technician for help.

Privacy of communications may not be ensured when using this equipment.



JUPITER AVIONICS
CORPORATION

Jupiter Avionics Corporation
1959 Kirschner Road
Kelowna BC
Canada V1Y 4N7
Tel: +1 778 478 2232
Toll-Free: 1 855 478 2232
www.jupiteravionics.com